

MBI5039 Application Note

(The article is suitable for the IC of version code B and datasheet of version V2.00)

Foreword

MBI5039 is a 16-channel constant current LED driver for LED display application. The LED current can be easily set up by an external resistor. The brightness of the LED can be further adjusted by connecting a PWM signal to the \overline{OE} of MBI5039. MBI5039 succeeds the last generation of LED driver in supply voltage ranging from 3.0V to 5.5V and in fast response time of output current with 35ns for LED display. Besides, MBI5039 enhances the performance of LED display. For example, the current gain, which is used for brightness control and current uniformity adjustment between different modules, is ranging from 12.5% to 200% in 64 steps.

MBI5039 features three different error detections. First, in-message error detection can detect individual LED from open- and short-circuit errors without extra control commands. Second, compulsory error detection can detect all output ports of LEDs as all LEDs are disable. Third, compulsory thermal detection can indicate an overheating condition when IC's junction temperature is over 150 (typ.). This article provides the application note according to the product characteristics or the problem which customers often meet.

Application Circuit

Figure 1 is the application circuit of MBI5039, which is compatible to MBI5025/5026/5027/5028/5029.

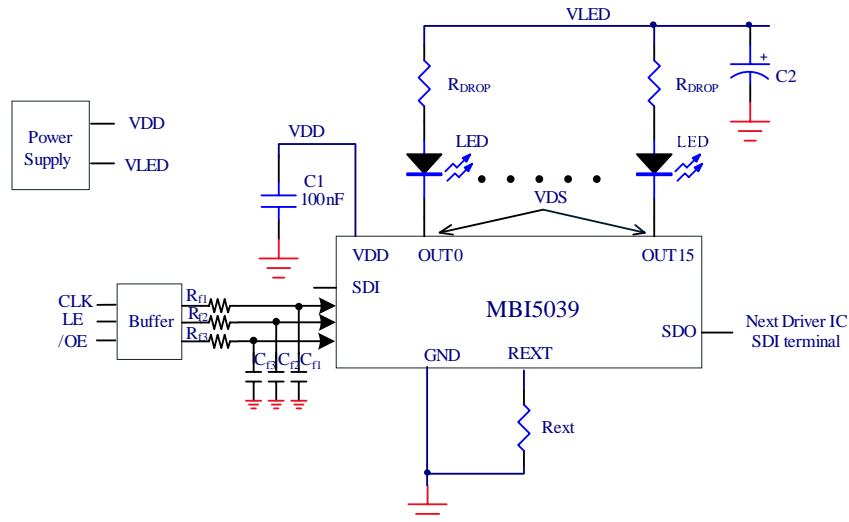

Figure 1. MBI5039 application circuit

Circuit Design

The value of V_{LED} is usually a concern when using constant current driver IC. If V_{DS} , as Figure 1 shows, is higher than the saturated (knee) voltage of constant current, it will cause overheating. However, if there is no sufficient voltage for output, the current of the output will not be constant. The suggestions for circuit design are below:

1. To Sort the LEDs by V_F

There is large variation in the forward voltages of different color LEDs. The forward voltage of blue or green color LED is about 3.3V~3.8V, and the red one is about 1.9V~2.4V. It is necessary to minimize the variation of LED forward voltage (V_F) within 0.5V. Basically, one driver IC controls one color LEDs.

2. To Select a Suitable R_{ext}

MBI5039 allows to set the LED current (I_{OUT}) by an external resistor, R_{ext} . A suitable R_{ext} can be calculated from the following (1):

$$R_{ext} = (0.61 \times G / I_{OUT}) \times 23, \dots\dots\dots(1)$$

Where, G is current gain.

The precise current range of MBI5039 is

- 8mA to 90mA at various V_{DD} ranging from 4.5V to 5.5V, and
- 3mA to 70mA at various V_{DD} ranging from 3.0V to 3.6V.

If output current is out of range, the current accuracy and line regulation will not be guaranteed.

3. To Decide V_{DS}

It is necessary to provide sufficient voltage for the output port of IC (V_{DS}) in order to keep a constant current. Figure 2 shows the relationship between I_{OUT} and V_{DS} at V_{DD} 5.0V for example. In general, the V_{DS} is slightly larger than the knee voltage and their correlation is $V_{DS}=V_{knee}+0.2V$. For example, 0.6V V_{DS} will be recommended if output current is set to 20mA.

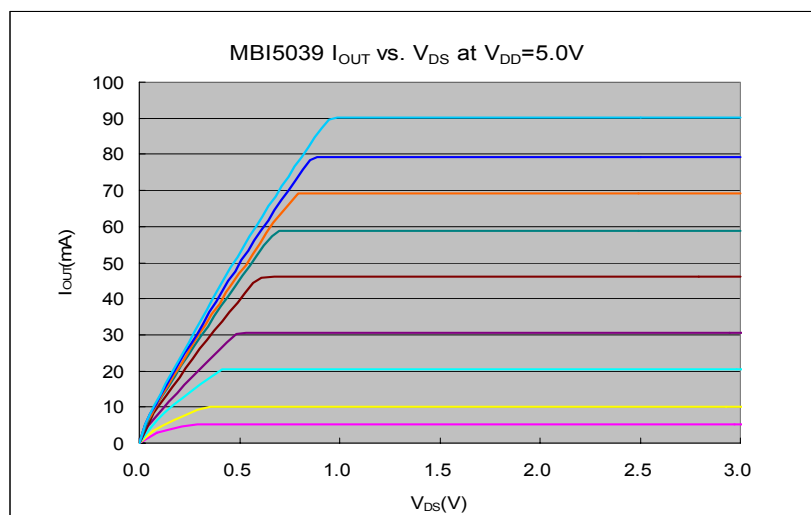

Figure 2. I_{OUT} vs. V_{DS}

4. To Decide $V_{LED, MIN}$ and Drop-down Resistor R_{DROP}

After setting the above conditions, the minimum V_{LED} ($V_{LED, MIN}$) can be determined by the following (2).

$$V_{LED, MIN} = (V_{F, MAX} \times n) + V_{DS}, \dots\dots\dots(2)$$

Where:

$V_{F, MAX}$ is the maximum forward voltage of LED, and

n is the cascaded LED count.

If the V_{LED} is an integer voltage (ex. the voltage of transformer is usually an integer one), the extra voltage (V_{DROP}) needs to be consumed by the drop-down resistor (R_{DROP}) cascaded with LEDs as shown in Figure 1. The value of the resistor can be calculated by following (3) and (4).

$$V_{DROP} = V_{LED, MIN} - (V_{F, MAX} \times n) - V_{DS} \dots\dots\dots(3)$$

$$R_{DROP} = V_{DROP} / I_{OUT} \dots\dots\dots(4)$$

5. Power Dissipation/ Heat Dissipation

In general applications, power dissipation is the major factor to raise the IC temperature. The greater power dissipation causes the higher temperature. The power dissipation can be calculated by the following (5).

$$P_D = (V_{DD} \times I_{DD}) + (V_{DS} \times I_{OUT}) \times m \dots\dots\dots(5)$$

Where:

m is the total IC output ports.

Then the temperature of IC can be approached by the following (6).

$$T_{IC} = T_A + R_{th} \times P_D, \dots\dots\dots(6)$$

Where:

T_{IC} is the temperature on IC,

T_A is the ambient temperature, and

R_{th} is the thermal resistance from junction to ambient temperature.

LED Display Control

The data transmission of MBI5039 is from the SDO pin of driver IC to the SDI pin of next driver IC. The serial data could be transferred into MBI5039 via the SDI of the first driver IC. CLK input terminal shifts data on rising edge. LE latches data and \overline{OE} enables output drivers to sink current. The basic control timing diagram of MBI5039 is the same as MBI5025/5026/5027/5028/5029.

Figure 3(a) gives an example of 4pcs MBI5039 ICs in cascade, and 3(b) shows the timing diagram for basic LED display control: The image data are transferred from the SDI of first driver IC to shift register by 16x4 CLK rising edge. And then as the falling edge of LE triggers, image data is transferred and latched into 16-bit output latch register. LE pulse should not cover CLK rising edge. In the following, when \overline{OE} changes from high to low (active), the output drivers are enabled.

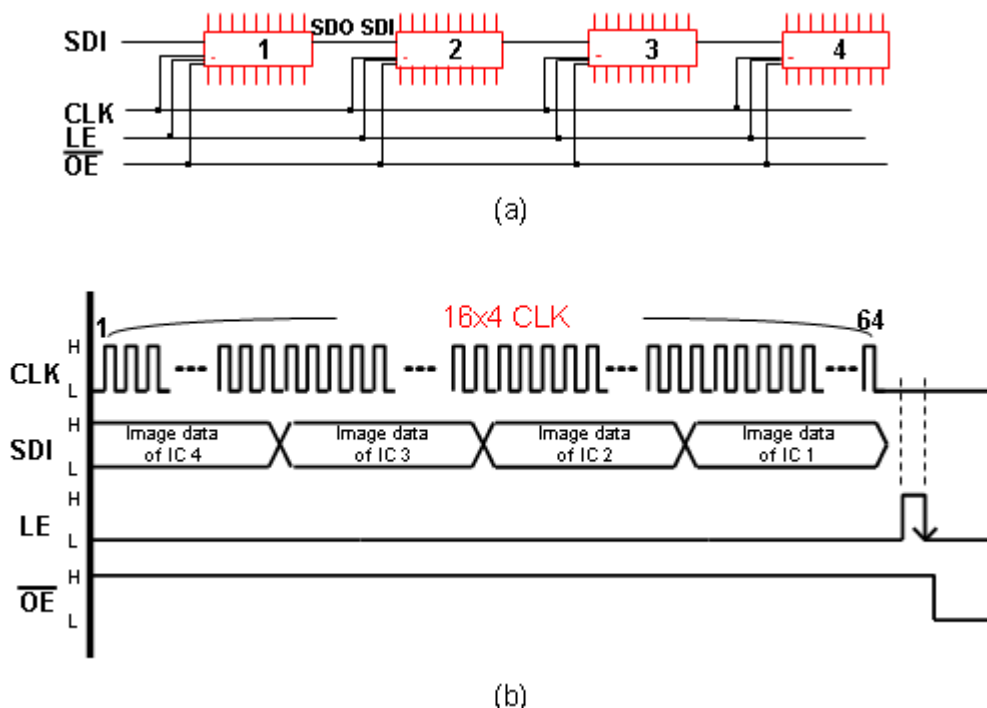

Figure 3(a). The sketch of 4pcs MBI5039 is in cascade.

3(b). The timing diagram of 4pcs MBI5039 is in cascade.

To control the LED current and brightness, a PWM signal should connect to the \overline{OE} pin of MBI5039. The larger duty cycle of the PWM signal results in the dimming brightness. The fast response time minimizes the pulse width of \overline{OE} to 35ns with good uniformity and quality.

In-message Error Detection

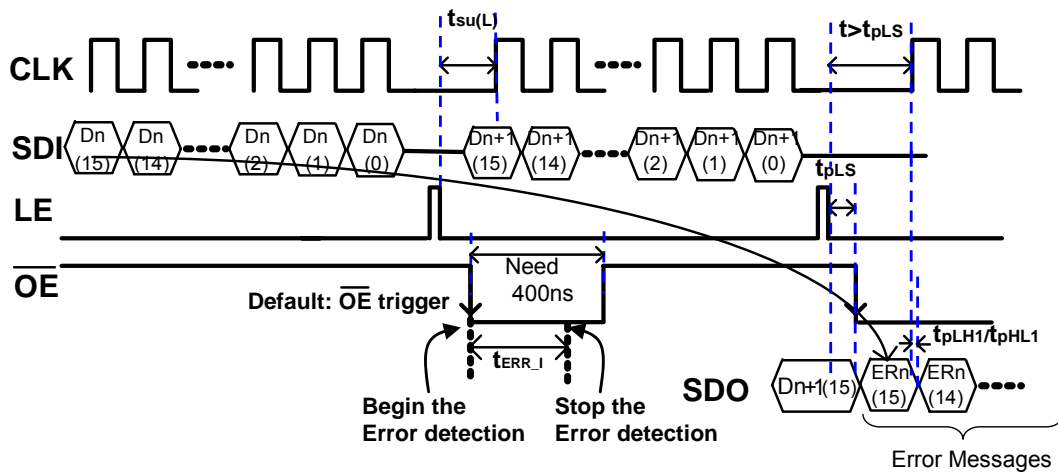

Figure 4. The timing diagram of entering in-message error detection

The default value of MBI5039 in-message error detection is disabled. The function needs to be enabled by entering configuration register and setting the bitB~bitA with 01, 10 or 11 into the configuration code. And then it can detect the LED's quality effectively.

As IC enables the output channels in Figure 4, it executes the in-message error detection simultaneously. When \overline{OE} keeps low for the duration of T_{ERR-I} (maximum is 400ns), the IC completes the error detection. The error messages are transferred to shift register during T_{PLS} at next LE falling edge and shifted out from SDO as the CLK pushes the new image data into shift register. The in-message error detection can identify the damaged LED correctly, but it cannot detect the error state of open-/short-circuit.

The error detection is based on the fact that the LED voltage drop is judged by comparing the effective voltage (V_{DS}) of each output port with the target voltage. If V_{DS} is lower than the open-circuit detection voltage (0.3V) or higher than the short-circuit detection voltage ($V_{SD,TH}=0.45xV_{DD}$, default), SDO reports the code 0 to indicate LED is in error. Be noted that user should not judge LED abnormal or not only by the code "1" or "0" transferring from SDO port. The information of SDO port is not always the error messages. As figure 4 shows, the timing of $D_{n+1}(15)$ readout from SDO port is image data, not error message.

In-message error detection is recommended in multi-LED cascaded application.

Error Detection in R-EXT Disconnected

If the R-EXT is floated, there is no output current in the output ports of MBI5039. The in-message error detection of MBI5039 can detect the situation and figure out this problem. When the power turns on, user can judge the state of R-EXT by the following steps.

Step 1: Determine the threshold voltage for short-circuit detection ($V_{SD,TH}$) and let it near the $V_{DS,ON}$. The $V_{SD,TH}$ should be larger than $V_{DS,ON}$, as in (7) shows.

$$V_{SD,TH} > V_{DS,ON} \dots\dots\dots(7)$$

Where:

$V_{DS,ON}$ is output voltage of turn-on channel.

Step 2: Write configuration code.

Step 3: Deliver the signal as Figure 3 shows. The SDI pin writes with the code of "FFFF (HEX)".

Step 4: Check the error message from SDO port at the next LE falling edge. If the error in R-EXT is detected, the code "0000 (HEX)" is delivered to SDO.

In-message Error Detection in Time-multiplexing Application

If we take the 1/2 duty time-multiplexing application as an example, the circuit is shown as figure 5. Two rows of LEDs share the same LED supply voltage, V_{LED} . By changing the MOSFET switch, the voltage of V_{LED} takes turns lighting up two rows of LEDs. During in-message error detection, make sure the error detection and error message of the first and the second row of LEDs are separated.

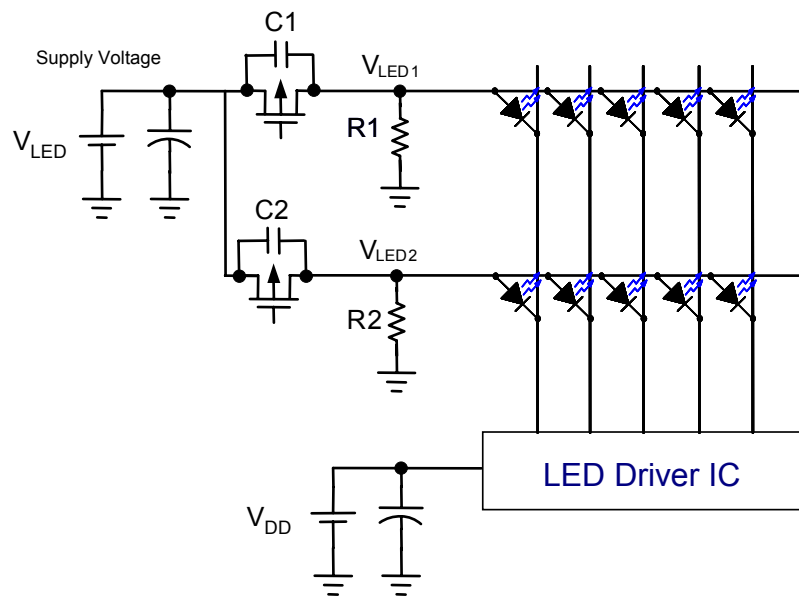

Figure 5. Time-multiplexing circuit diagram

During error detection, the power of V_{LED} should remain stable. In addition, when short circuit error detection is being processed, the supply voltage of previous LED row should completely discharge to 0V. It is recommended to connect with the discharged resistor, R1 and R2, between V_{LED} and GND to discharge the remaining V_{LED} , as figure 5 shows. Typically, the resistance is 5.1K Ω and it can be adjusted based on the actual electric circuit situation.

The timing diagrams of time-multiplexing error detection are suggested as figure 6 and figure 7. Figure 6 shows the timing diagram of error detection triggered by LE or \overline{OE} .

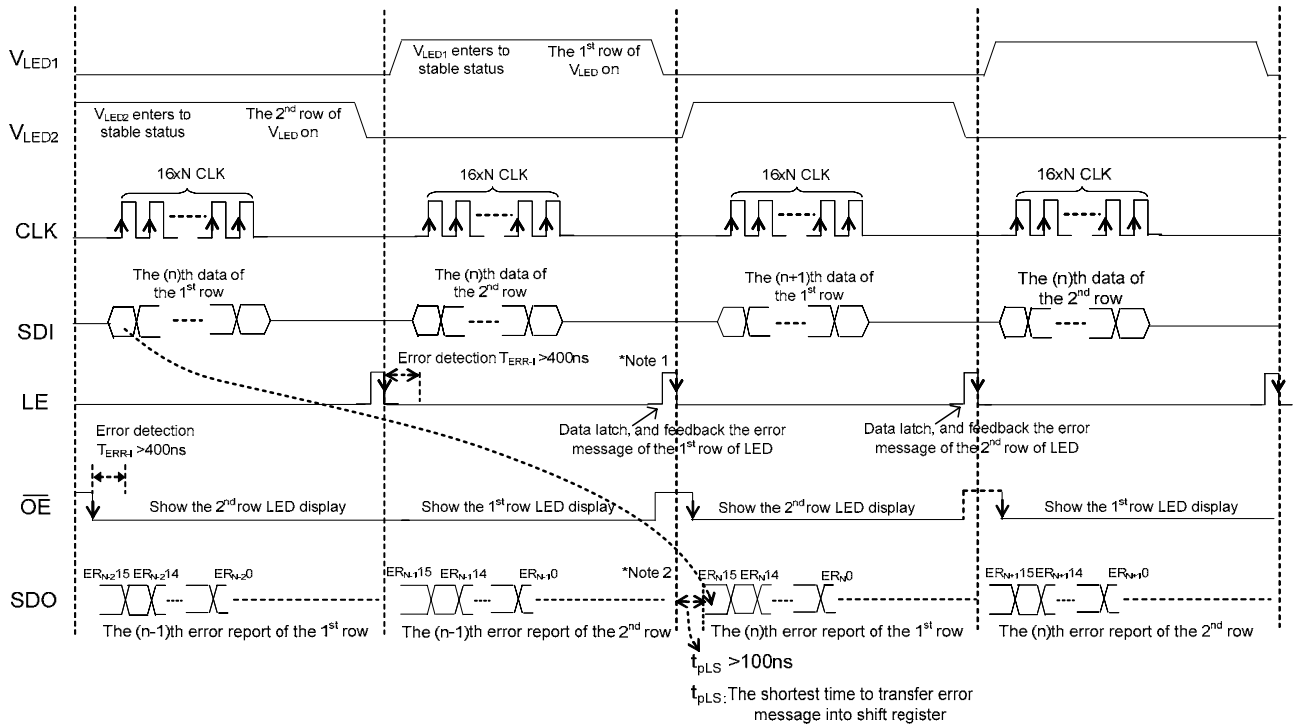

Figure 6. In-message error detection by 1/2 duty time-multiplexing circuit – error detection is triggered by LE or \overline{OE}

*Note 1. To avoid the visible transferring image, the data is latched when V_{LED1} and V_{LED2} turn OFF.

*Note 2. After triggering the LE falling edge, duration of t_{pLS} to read error message is required.

Figure 7 shows the timing diagram of error detection triggered by LE falling edge (because \overline{OE} connects to the ground).

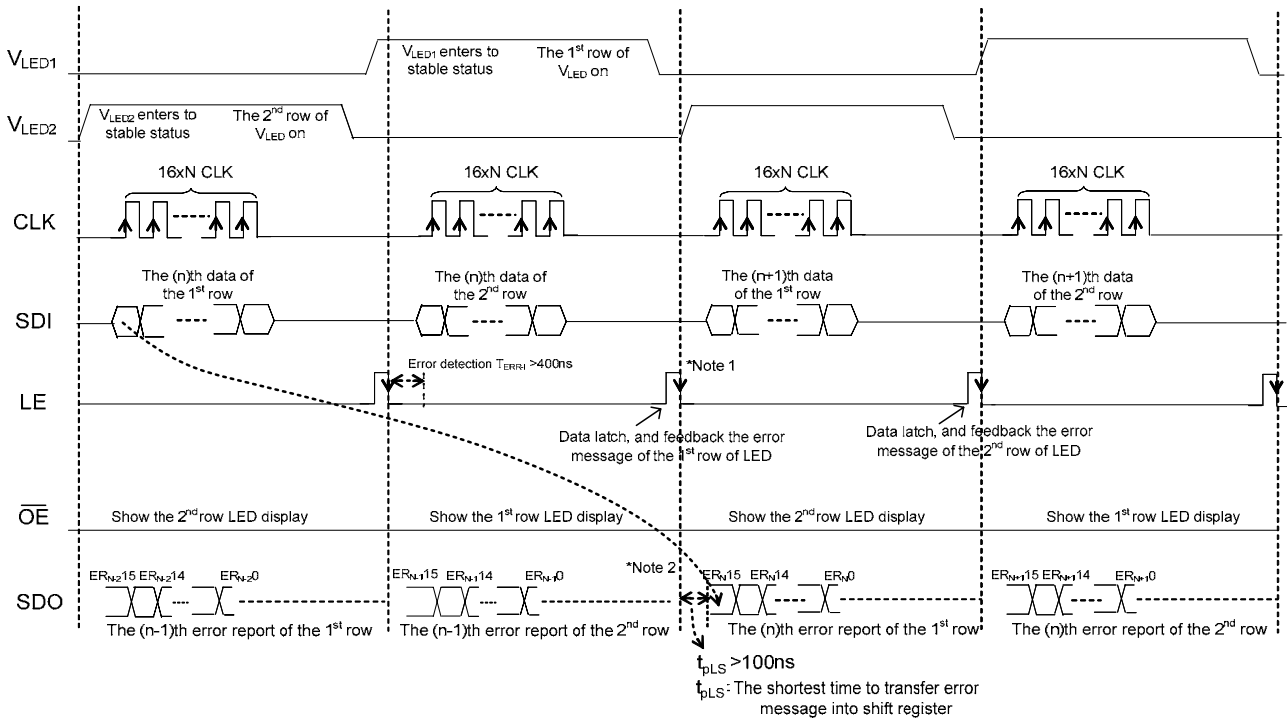

Figure 7. In-message error detection by 1/2 duty time-multiplexing circuit – error detection is triggered by LE

*Note 1. To avoid the visible transferring image, the data is latched when V_{LED1} and V_{LED2} turn OFF.

*Note 2. After triggering LE falling edge, duration of t_{pLS} to read error message is required.

Compulsory Error Detection

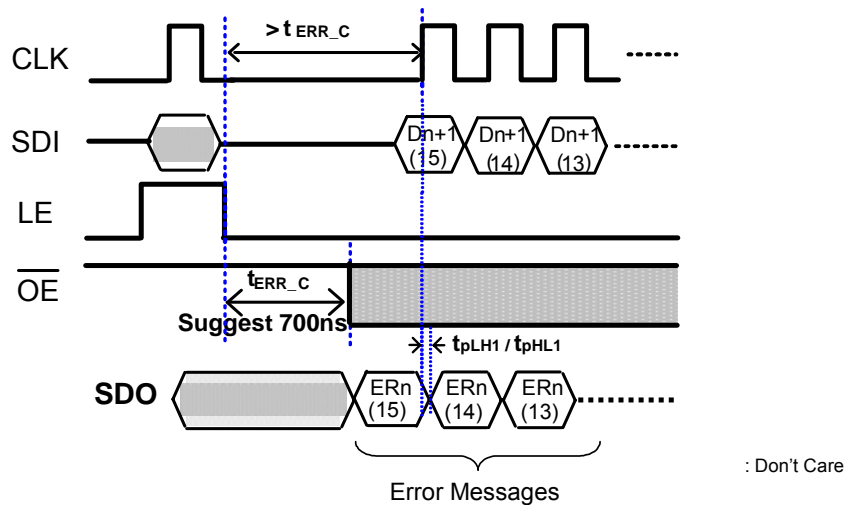

Figure 8. The timing diagram of compulsory open circuit error detection

As entering compulsory error detection of MBI5039, the short detection time and small forward current result in low voltage on LED. Thus, please do not execute the compulsory error detection right after power-on or before all channels are not turned-on yet.

When running the compulsory error detection, MBI5039 turns on all the channels by the forward current of 0.25mA in t_{ERR_C} (maximum is 700ns). It can avoid the flicker and noise impact on the image quality of LED display. Be noted that the slow response time of LED results in low LED voltage drop. Thus, it will affect the effective voltage value of each output port compared with the target voltage, and the detection result may be incorrect.

The voltage thresholds default of MBI5039 short-circuit detection is $0.45 \times V_{DD}$. Before running the compulsory error detection, enter configuration register mode first, and then set the bitF~bitE with 11: $0.73 \times V_{DD}$ as the target voltage of short-circuit error detection. During error detection, \overline{OE} should keep at high level for one period of t_{ERR_C} to get the effective error report. After that, the error report will be latched into shift register and delivered to SDO by CLK shift-in, shows in figure 8.

During the error detection, switching noise from power source or output channel should be avoided to affect the output voltage (V_{DS}). Besides, \overline{OE} should be avoided to fix at 0V or connected to the ground because compulsory error detection cannot work as \overline{OE} low.

Compulsory Error Detection in Time-Multiplexing Application

In figure 9, the timing diagram of compulsory error detection in 1/2 duty time-multiplexing circuit explains the short circuit error detection.

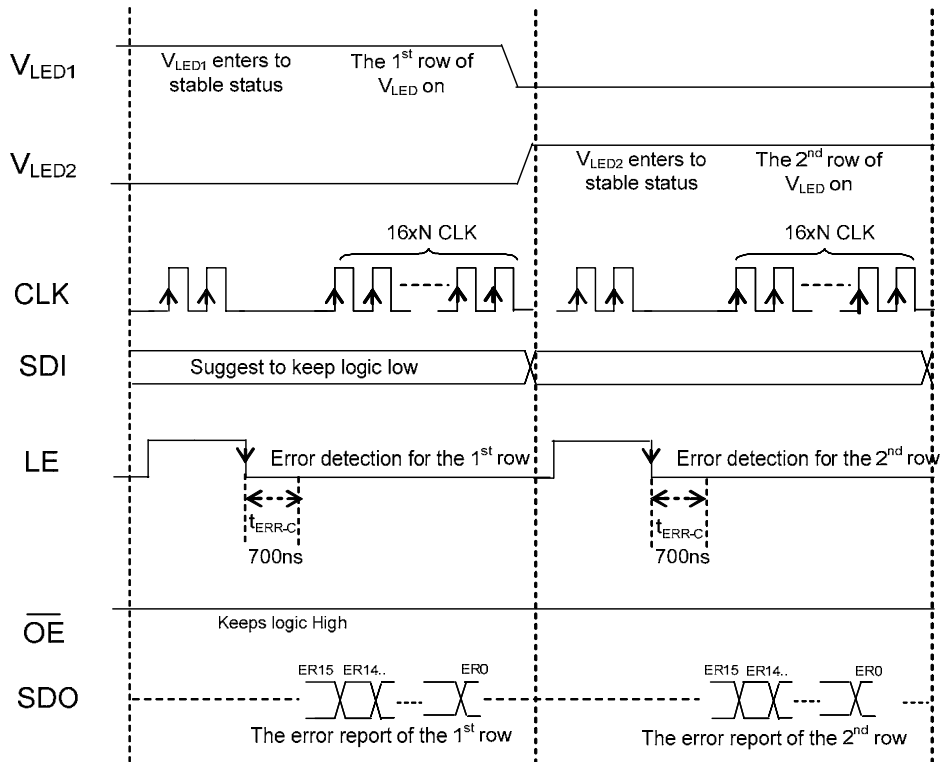

Figure 9. The timing diagram of compulsory short error detection in 1/2 duty time-multiplexing circuit

Compulsory error detection turns on all the channels by the forward current of 0.25mA in t_{ERR-C} . Due to the limited time interval and current of short circuit detection, PCB layout should avoid parasitical inductor effect from causing low voltage drop on LED. The recommended layout distance from LED cathode to IC output port should be shorter than 15cm, as figure 10 shows.

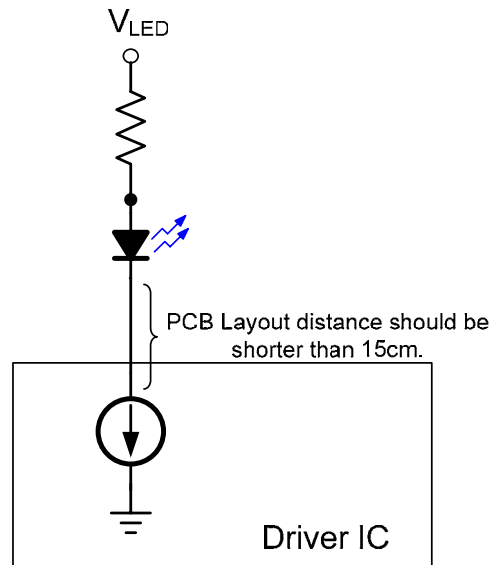

Figure 10. PCB Layout Limitation

Compulsory Thermal Detection

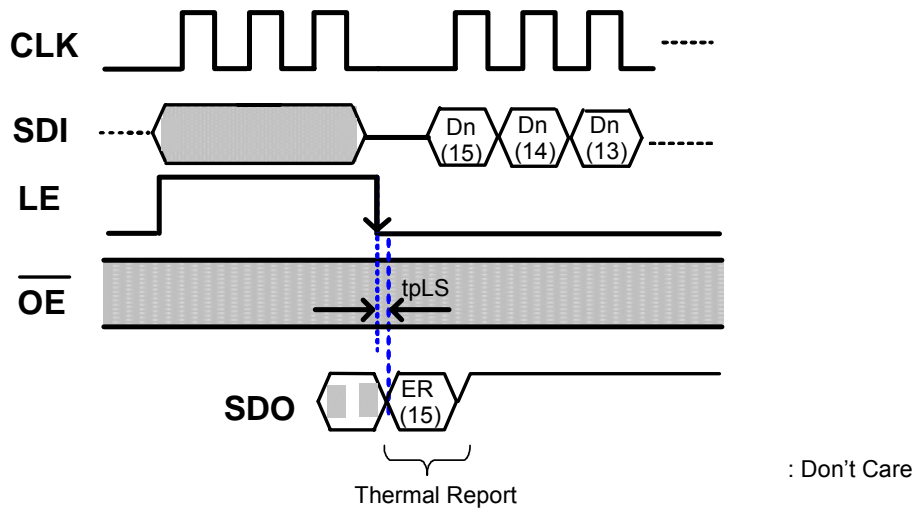

Figure 11. The timing diagram of entering in compulsory thermal detection

The timing diagram of entering in compulsory thermal detection is shown in Figure 11. When LE is asserted at 3 CLK rising edges and after LE falling edge, MBI5039 enters in compulsory thermal detection instantly and detects the temperature of IC. The \overline{OE} signal could be high or low.

When the junction temperature reaches 150 °C, the code of “7FFF (HEX)” is delivered to SDO.

Configuration Register Setting

Figure 12 is the configuration register timing diagram for one driver IC. When LE is asserted at 4 of CLK rising edges, the data in shift register will be recognized as the configuration code.

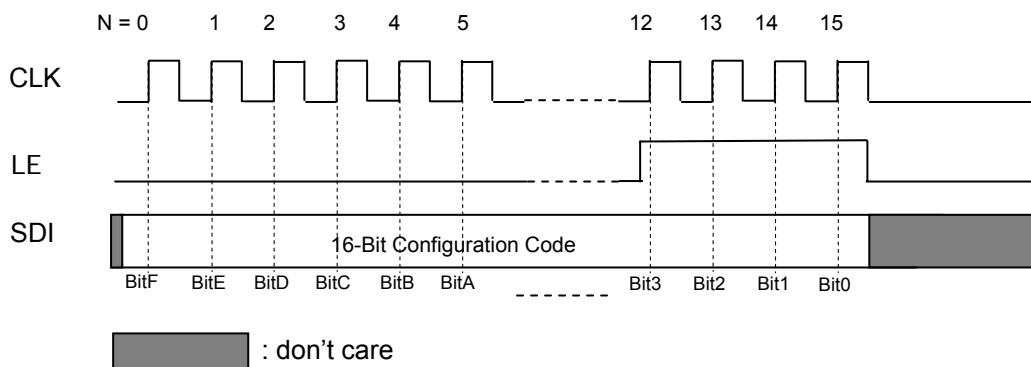

Figure 12. The configuration register timing diagram for one driver IC

Figure 13 is the configuration register timing diagram for several ICs in cascaded. The configuration code of each IC transfers from SDI port to shift register by triggering the rising edge of CLK. LE keeps low from the 1st CLK to the $[(16 \times N) - 4]^{\text{th}}$ CLK, then changes to high in the last 4 CLK rising edges. And then, after LE falling edge, the contents in the shift register will be transferred to the configuration register, not to data latch register.

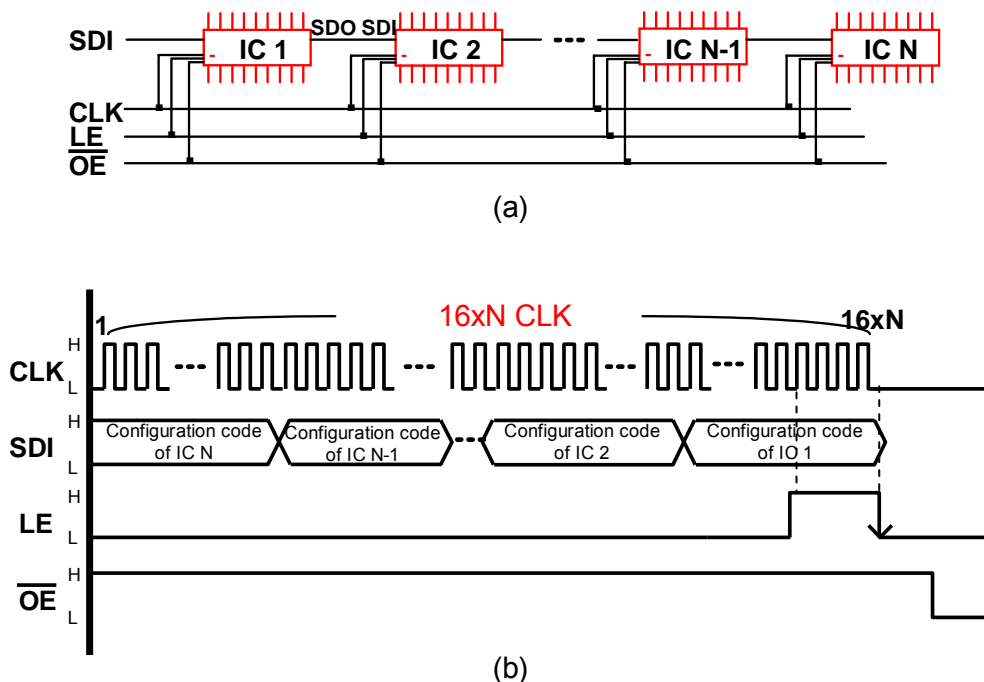

Figure 13. The configuration register timing diagram for several serial connecting ICs.

The default value of configuration register is

F	E	D	C	B	A	Check Bits				5	4	3	2	1	0
0	1	1	1	0	0	9	8	7	6	6'b101011					
						0	1	0	1						

After entering the write configuration mode, the system controller sends a 16-bit configuration register setting which must include check bits (bit9~bit6 = 0101) to the 16-bit shift register through the SDI pin. If the check bits are not equal to "0101", the data will not be updated to the configuration register.

When driver board does hot plug action, noise signal might make MBI5039 enter un-expected mode. If MBI5039 enters the un-expected configuration register mode and changes the current gain or configuration register setting, it will induce application problem.

Thus, hot plug action is not recommended. If users can not avoid it, please re-write configuration register setting again after hot plug action, and then run the read configuration mode to confirm the setting contents of configuration register.

Current Gain Adjustment

In configuration code, Bit5~Bit0 set current gain and the range is from 6'b000000 to 6'b111111.

	F	E	D	C	B	A	9	8	7	6	5	4	3	2	1	0
Definition	-	-	-	-	-	-	-	-	-	-	HC	DA4	DA3	DA2	DA1	DA0
Default											1	0	1	0	1	1

→ 6-bit Current Adjustment Code ←

Take 20mA I_{OUT} and current gain $G = 1$ for example. The following will show the steps to get the current adjust code for corresponding current gain.

Step 1: Get R_{ext} , D, and HC by (8), (9) & (10).

$$V_{R-EXT} = 0.61\text{Volt} \times G; I_{OUT} = (V_{R-EXT}/R_{ext}) \times 23.0 \dots\dots\dots(8)$$

$$\text{If HC}=1, \text{ take D into the formula } D = (65 \times G - 33)/3 \dots\dots\dots(9)$$

$$\text{If HC}=0, \text{ take D into the formula } D = (256 \times G - 32)/3, \dots\dots\dots(10)$$

Where:

HC=1 represents high current band ($G \geq 0.5$ or $D \geq 32$),

HC=0 represents low current band. ($G < 0.5$ or $D < 32$),

D is the decimal numeration.

In (8), $R_{ext} = (0.61 \times 1) / 0.02 \times 23 = 701.5(\Omega)$.

Current gain $G=1$ is larger than 0.5,

In (9), the $HC=1$ and D is 10.67. The value of D should take as integer, 11.

Step 2: Take $D = 11$ into (11), and then the current adjustment code can be calculated by

$$D = DA4 \times 2^4 + DA3 \times 2^3 + DA2 \times 2^2 + DA1 \times 2^1 + DA0 \times 2^0 \dots\dots\dots(11)$$

And then the current adjustment code of DA[4:0] is 01011.

Step 3: Set 6-bit (bit5~bit0) of configuration register in 6'b101011.

If R_{ext} keeps the same, the steps to change current adjustment code to increase I_{OUT} to 30mA are below:

Step 1: In (8), the current gain G changes to 1.5.

Step 2: Following step 1, the $HC=1$ and $D= (65 \times 1.5 - 33) / 3 = 21.5 \quad 22$

Step 3: Take $D = 22$ into (11), and then the current adjustment code of $DA[4:0]$ is 10110.

Step 4: Set 6-bit (bit5~bit0) of configuration register in 6'b110110.

If R_{ext} keeps the same, the steps to change current adjustment code to decrease I_{OUT} to 5mA are below:

Step 1: In (8), the current gain G changes to 0.25.

Step 2: Following step 1, because current gain G is lower than 0.5, the $HC=0$ and

$$D = (256 \times 0.25 - 32) / 3 = 10.67 \quad 11.$$

Step 3: Take $D = 11$ into (11), and then the current adjustment code of $DA[4:0]$ is 01011.

Step 4: Set 6-bit (bit5~bit0) of configuration register in 6'b001011.

Figure 14 shows the relationship between the current adjustment code and the gain of output current. When default current adjustment code of IC is 6'b101011, the gain of output current is 1.015.

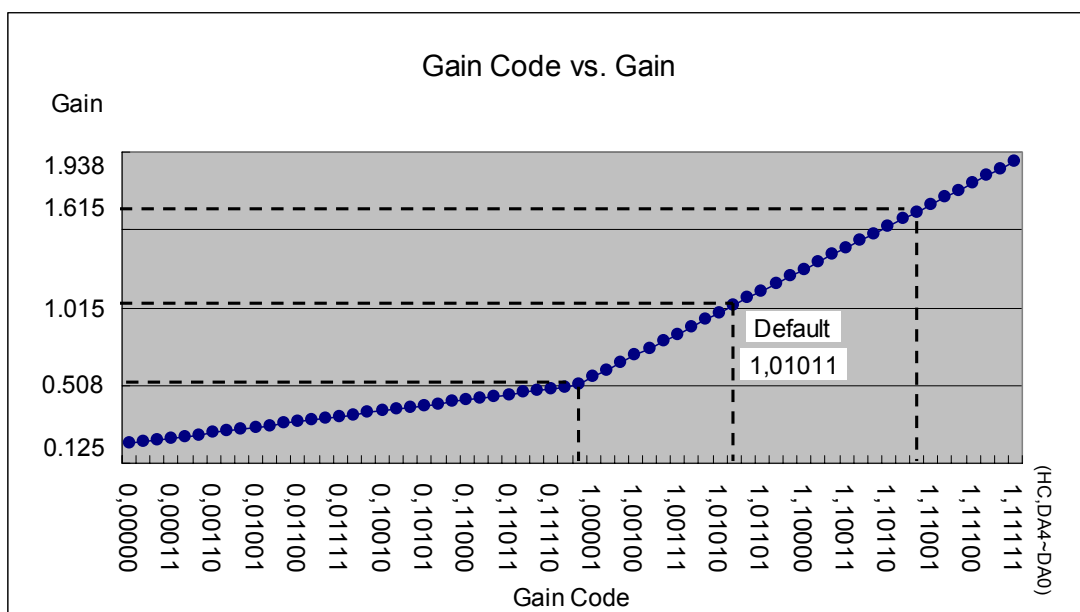

Figure 14. The relationship between gain code and the gain of output current

Figure 15 is the example of the relationship between the gain of output current and I_{OUT} at 3.3V application with $R_{ext}=700\Omega$. When the default gain of output current is 1.015, the output current is 20.1mA.

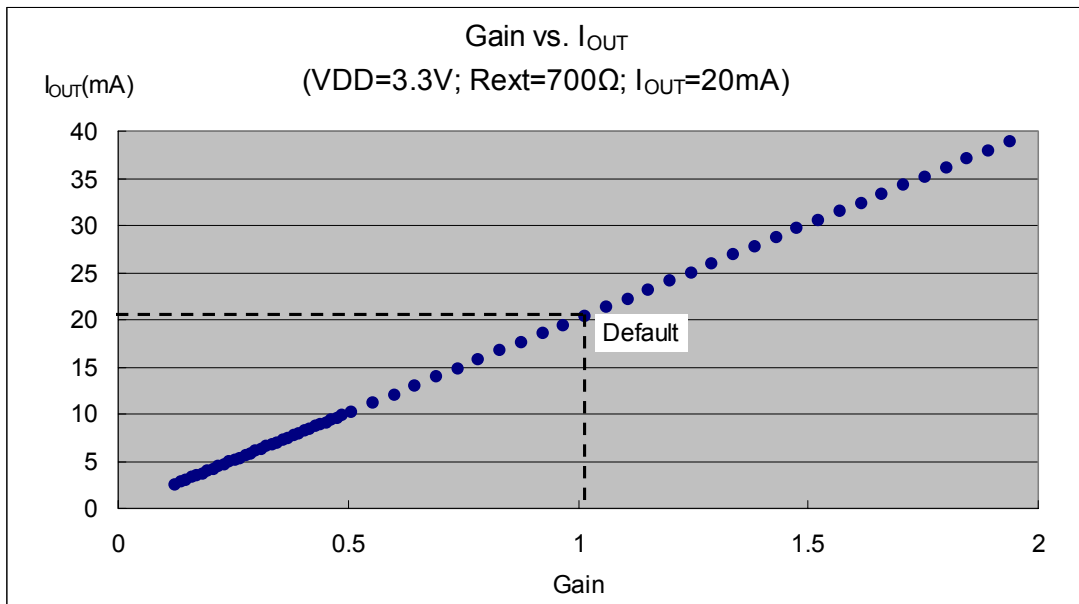

Figure 15. The relationship between the gain of output current and I_{OUT} at 3.3V application with $R_{ext}=700\Omega$

The Trigger Mode of In-Message Error Detection

The default value of configuration register is shown as below.

F	E	D	C	B	A	9	8	7	6	5	4	3	2	1	0
0	1	1	1	0	0	0	1	0	1	6'b101011					

Table 1. The trigger mode selection of in-message error detection

Bit	Definition	Value	Function
D~C	Operation of in-message error detection	00	Disable in message error detection; SDO shifts out input data from SDI.
		01	Enable LE to trigger in-message error detection; SDO shift out error code as "Error Code" section*.
		10 (Default)	Enable \overline{OE} to trigger in-message error detection; SDO shift out error code as "Error Code" section*.
		11	Enable \overline{OE} or LE to trigger in-message error detection; SDO shift out error code as "Error Code" section*.

* Please refer to the page 19 of MBI5039 datasheet.

In in-message error detection, default trigger mode is \overline{OE} falling edge. There are still another two trigger modes which can be selected from configuration register setting. The purpose is to connect the driver board with \overline{OE} pin directly to GND.

\overline{OE} Trigger (Default)

When the \overline{OE} falling edge triggers the in-message error detection, MBI5039 enters in error detection. During the in-message error detection, \overline{OE} should keep at low level for t_{ERR-I} at least to get the effective error report. The correct timing diagram is shown as figure 16(a). If the duration of \overline{OE} at low is shorter than t_{ERR-I} , which is shown in figure 16(b), MBI5039 will stop error detection instantly and the code "FFFF(HEX)" will be delivered to shift register.

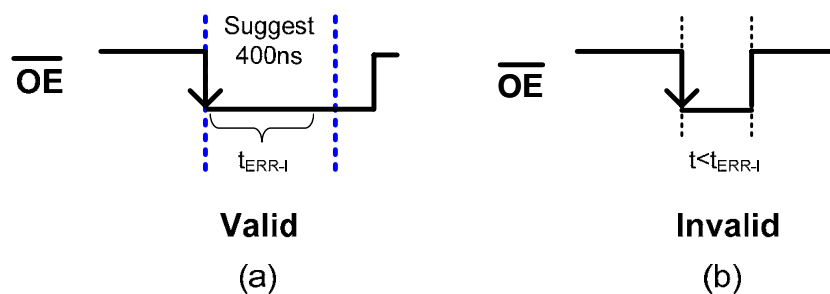

Figure 16. The trigger mode of in-message error detection is \overline{OE} at falling edge

LE Trigger

It is recommended to use LE trigger mode for designing the driver board with \overline{OE} pin directly connecting to GND. When LE falling edge triggers, IC detects \overline{OE} level automatically. If \overline{OE} is low, it starts the in-message error detection. If \overline{OE} is high, it will not enter in error detection function.

During the in-message error detection, the time of t_1 in figure 17(a) needs to be larger than 5ns. Then \overline{OE} keeps low at least t_{ERR-I} to get the effective error report. The correct timing diagram is shown in figure 17(a). If \overline{OE} is high at LE falling edge, or if the duration of \overline{OE} at low level is shorter than t_{ERR-I} , as figure 17(b) and figure 17(c) show, MBI5039 will not do error detection successfully and the code "FFFF(HEX)" will be delivered to shift register.

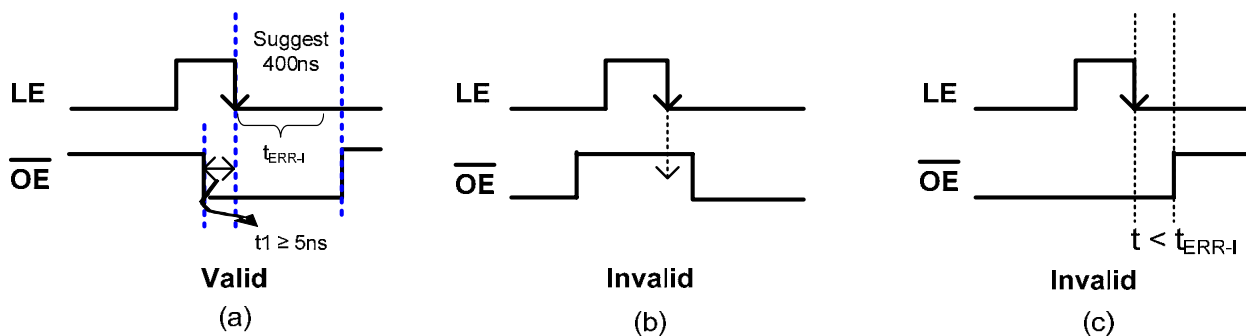

Figure 17. The trigger mode of in-message error detection is LE at falling edge

LE or $\overline{\text{OE}}$ Trigger

The way to set MBI5039 in LE or $\overline{\text{OE}}$ trigger mode are: (1). When the LE falling edge, $\overline{\text{OE}}$ keeps low. (2). When the $\overline{\text{OE}}$ falling edge.

The valid timing diagram is shown as figure 18(a) and 18(b). During the in-message error detection, the time of t_1 in figure 18(a) needs to be larger than 5ns. Then $\overline{\text{OE}}$ keeps low at least $t_{\text{ERR-I}}$ to get the effective error message. If duration of $\overline{\text{OE}}$ at low is shorter than $t_{\text{ERR-I}}$, MBI5039 will stop error detection instantly and the code "FFFF (HEX)" will deliver to shift register.

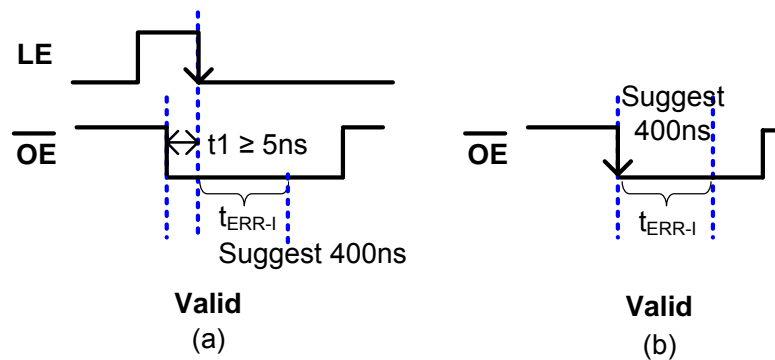

Figure 18. Application note as triggered by LE or $\overline{\text{OE}}$

V_{SD,TH} Selection

Configuration register default value shows below:

F	E	D	C	B	A	9	8	7	6	5	4	3	2	1	0
0	1	1	1	0	0	0	1	0	1	6'b101011					

Table 2. The voltage thresholds selection for short-circuit detection

Bit	Definition	Value	Function
F~E	Voltage thresholds for short-circuit detection (V _{SD,TH})	00	0.33 x VDD ± 0.1V
		01(Default)	0.45 x VDD ± 0.1V
		10	0.58 x VDD ± 0.1V
		11	0.73 x VDD ± 0.1V (Compulsory error detection) 0.73 x VDD + 0.4V (In-message error detection)

Setting in In-message Error Detection

The way to choose suitable short circuit detection point, V_{SD,TH} is below:

In (12), the V_{DS,MAX} of normal LED is

$$V_{DS,MAX} = V_{LED} - V_{DROP} - (V_{F,MIN} \times n) \dots \dots \dots (12)$$

Choose short circuit detection point in configuration register to satisfy (13).

$$V_{SD,TH} > V_{DS,MAX} + 0.5V \dots \dots \dots (13)$$

There is an example as below:

Ex: The minimum forward voltage of Red LED is 2.2V at 20mA forward current. V_{DD} and V_{LED} are 5V. R_{DROP} is 100Ω. It is belong to static type application with connecting one LED at output load. Then, choose a suitable V_{SD,TH} to run the in-message error detection.

In (12), we can get

$$V_{DS,MAX} = V_{LED} - V_{DROP} - (V_{F,MIN} \times n) = 5 - 0.02 \times 100 - 2.2 \times 1 = 0.8 (V)$$

Take V_{DS,MAX}=0.8V into (13).

$$V_{SD,TH} > V_{DS,MAX} + 0.5V = 0.8 + 0.5V = 1.3V$$

V_{SD,TH} should be higher than 1.3V. 0.33xVDD (=1.65V) for short voltage detection point is recommended.

Setting in Compulsory Error Detection

In order to avoid the flicker and noise impact on the image quality of LED display, MBI5039 turns on all the output channels by 0.25mA forward current in t_{ERR-C} when running compulsory error detection. During the time, the forward voltage of LED is $V_{F,OFF}$, as shown in figure 19. Before enter in compulsory error detection, $0.73 \times V_{DD}$ (the highest level) in the configuration register is recommended for short circuit detection point.

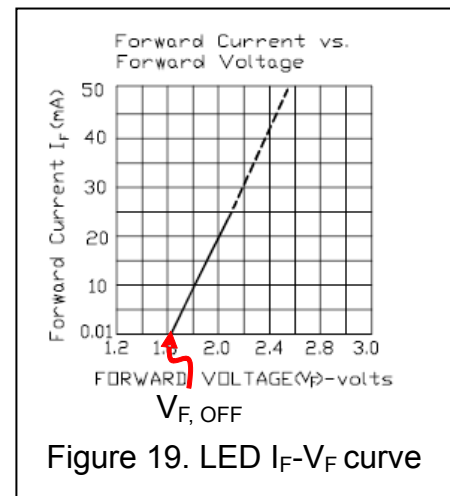

Conclusion

This application note provides the detailed functional instructions of MBI5039 to help user in correct design including the output current setting, the control method of LED display, in-message error detection, compulsory open circuit/ short circuit error detection functions, over-temperature warning and programmable current gain from 12.5% to 200%.