



CALL NO. 201

CONTRACT ID. 212955

KENTON COUNTY

FED/STATE PROJECT NUMBER 059GR21M007 - NHPP

DESCRIPTION LEXINGTON-CINCINNATI ROAD (I-71 / I-75)

WORK TYPE BRIDGE PAINTING & CLEANING

PRIMARY COMPLETION DATE 11/15/2021

LETTING DATE: January 29,2021

Sealed Bids will be received electronically through the Bid Express bidding service until 10:00 am EASTERN STANDARD TIME January 29,2021. Bids will be publicly announced at 10:00 am EASTERN STANDARD TIME.

NO PLANS ASSOCIATED WITH THIS PROJECT.

DBE CERTIFICATION REQUIRED - 0%

REQUIRED BID PROPOSAL GUARANTY: Not less than 5% of the total bid.

TABLE OF CONTENTS

PART I	SCOPE OF WORK
	<ul style="list-style-type: none">• PROJECT(S), COMPLETION DATE(S), & LIQUIDATED DAMAGES• CONTRACT NOTES• FEDERAL CONTRACT NOTES• EXPEDITE WORK ORDER• SPECIAL NOTE(S) APPLICABLE TO PROJECT• LIQUIDATED DAMAGES• RIGHT OF WAY CERTIFICATION• UTILITY IMPACT & RAIL CERTIFICATION NOTES• MATERIAL SUMMARY• BRIDGE DRAWINGS• PRE-BID CONFERENCE
PART II	SPECIFICATIONS AND STANDARD DRAWINGS
	<ul style="list-style-type: none">• SPECIFICATIONS REFERENCE• SUPPLEMENTAL SPECIFICATION
PART III	EMPLOYMENT, WAGE AND RECORD REQUIREMENTS
	<ul style="list-style-type: none">• FEDERAL-AID CONSTRUCTION CONTRACTS - FHWA 1273• NONDISCRIMINATION OF EMPLOYEES• EXECUTIVE BRANCH CODE OF ETHICS• PROJECT WAGE RATES (OTHER STATE)• PROJECT WAGE RATES LOCALITY 3 / FEDERAL• NOTICE OF REQUIREMENT FOR AFFIRMATIVE ACTION TO ENSURE EEO KENTON
PART IV	INSURANCE
PART V	BID ITEMS

PART I
SCOPE OF WORK

ADMINISTRATIVE DISTRICT - 06

CONTRACT ID - 212955

059GR21M007 - NHPP

COUNTY - KENTON

PCN - MB05900752101

NHPP IM 0758 (107)

LEXINGTON-CINCINNATI ROAD (I-71/I-75) BRENT SPENCE BRIDGE (059B00040N) OVER OHIO RIVER,
KENTUCKY APPROACH AT MP 191.25.BRIDGE PAINTING & CLEANING SYP NO. 06-00017.09.

GEOGRAPHIC COORDINATES LATITUDE 39:05:05.00 LONGITUDE 84:31:22.00

PCN - MB05900752102

NHPP IM 0758 (107)

LEXINGTON-CINCINNATI ROAD (I-71/I-75) BRENT SPENCE BRIDGE (059B00046N) OVER OHIO RIVER, MAIN
RIVER TRUSS AT MP 191.25.BRIDGE PAINTING & CLEANING SYP NO. 06-00017.09.

GEOGRAPHIC COORDINATES LATITUDE 39:05:26.00 LONGITUDE 84:31:21.00

PCN - MB05900752103

NHPP IM 0758 (107)

LEXINGTON-CINCINNATI ROAD (I-71/I-75) BRENT SPENCE BRIDGE (HAM-0071-000L/R) OVER OHIO RIVER, OHIO
APPROACH AT MP 191.25.BRIDGE PAINTING & CLEANING SYP NO. 06-00017.09.

GEOGRAPHIC COORDINATES LATITUDE 39:05:26.00 LONGITUDE 84:31:21.00

COMPLETION DATE(S):

COMPLETED BY 11/15/2021

APPLIES TO ENTIRE CONTRACT

CONTRACT NOTES

PROPOSAL ADDENDA

All addenda to this proposal must be applied when calculating bid and certified in the bid packet submitted to the Kentucky Department of Highways. Failure to use the correct and most recent addenda may result in the bid being rejected.

BID SUBMITTAL

Bidder must use the Department's electronic bidding software. The Bidder must download the bid file located on the Bid Express website (www.bidx.com) to prepare a bid packet for submission to the Department. The bidder must submit electronically using Bid Express.

JOINT VENTURE BIDDING

Joint venture bidding is permissible. All companies in the joint venture must be prequalified in one of the work types in the Qualifications for Bidders for the project. The bidders must get a vendor ID for the joint venture from the Division of Construction Procurement and register the joint venture as a bidder on the project. Also, the joint venture must obtain a digital ID from Bid Express to submit a bid. A joint bid bond of 5% may be submitted for both companies or each company may submit a separate bond of 5%.

UNDERGROUND FACILITY DAMAGE PROTECTION

The contractor shall make every effort to protect underground facilities from damage as prescribed in the Underground Facility Damage Protection Act of 1994, Kentucky Revised Statute KRS 367.4901 to 367.4917. It is the contractor's responsibility to determine and take steps necessary to be in compliance with federal and state damage prevention directives. When prescribed in said directives, the contractor shall submit Excavation Locate Requests to the Kentucky Contact Center (KY811) via web ticket entry. The submission of this request does not relieve the contractor from the responsibility of contacting non-member facility owners, whom shall be contacted through their individual Protection Notification Center. Non-compliance with these directives can result in the enforcement of penalties.

REGISTRATION WITH THE SECRETARY OF STATE BY A FOREIGN ENTITY

Pursuant to KRS 176.085(1)(b), an agency, department, office, or political subdivision of the Commonwealth of Kentucky shall not award a state contract to a person that is a foreign entity required by [KRS 14A.9-010](#) to obtain a certificate of authority to transact business in the Commonwealth ("certificate") from the Secretary of State under [KRS 14A.9-030](#) unless the person produces the certificate within fourteen (14) days of the bid or proposal opening. If the foreign entity is not required to obtain a certificate as provided in [KRS 14A.9-010](#), the foreign entity should identify the applicable exception. Foreign entity is defined within [KRS 14A.1-070](#).

For all foreign entities required to obtain a certificate of authority to transact business in the Commonwealth, if a copy of the certificate is not received by the contracting agency within the time frame identified above, the foreign entity's solicitation response shall be deemed non-responsive or the awarded contract shall be cancelled.

Businesses can register with the Secretary of State at <https://secure.kentucky.gov/sos/ftbr/welcome.aspx>.

SPECIAL NOTE FOR PROJECT QUESTIONS DURING ADVERTISEMENT

Questions about projects during the advertisement should be submitted in writing to the Division of Construction Procurement. This may be done by fax (502) 564-7299 or email to kytc.projectquestions@ky.gov. The Department will attempt to answer all submitted questions. The Department reserves the right not to answer if the question is not pertinent or does not aid in clarifying the project intent.

The deadline for posting answers will be 3:00 pm Eastern Daylight Time, the day preceding the Letting. Questions may be submitted until this deadline with the understanding that the later a question is submitted, the less likely an answer will be able to be provided.

The questions and answers will be posted for each Letting under the heading "Questions & Answers" on the Construction Procurement website (www.transportation.ky.gov/contract). The answers provided shall be considered part of this Special Note and, in case of a discrepancy, will govern over all other bidding documents.

HARDWOOD REMOVAL RESTRICTIONS

The US Department of Agriculture has imposed a quarantine in Kentucky and several surrounding states, to prevent the spread of an invasive insect, the emerald ash borer. Hardwood cut in conjunction with the project may not be removed from the state. Chipping or burning on site is the preferred method of disposal.

INSTRUCTIONS FOR EXCESS MATERIAL SITES AND BORROW SITES

Identification of excess material sites and borrow sites shall be the responsibility of the Contractor. The Contractor shall be responsible for compliance with all applicable state and federal laws and may wish to consult with the US Fish and Wildlife Service to seek protection under Section 10 of the Endangered Species Act for these activities.

ACCESS TO RECORDS

The contractor, as defined in KRS 45A.030 (9) agrees that the contracting agency, the Finance and Administration Cabinet, the Auditor of Public Accounts, and the Legislative Research Commission, or their duly authorized representatives, shall have access to any books, documents, papers, records, or other evidence, which are directly pertinent to this contract for the purpose of financial audit or program review. Records and other prequalification information confidentially

disclosed as part of the bid process shall not be deemed as directly pertinent to the contract and shall be exempt from disclosure as provided in KRS 61.878(1)(c). The contractor also recognizes that any books, documents, papers, records, or other evidence, received during a financial audit or program review shall be subject to the Kentucky Open Records Act, KRS 61.870 to 61.884.

In the event of a dispute between the contractor and the contracting agency, Attorney General, or the Auditor of Public Accounts over documents that are eligible for production and review, the Finance and Administration Cabinet shall review the dispute and issue a determination, in accordance with Secretary's Order 11-004.

April 30, 2018

FEDERAL CONTRACT NOTES

The Kentucky Department of Highways, in accordance with the Regulations of the United States Department of Transportation 23 CFR 635.112 (h), hereby notifies all bidders that failure by a bidder to comply with all applicable sections of the current Kentucky Standard Specifications, including, but not limited to the following, may result in a bid not being considered responsive and thus not eligible to be considered for award:

- | | |
|--------------------------------|--|
| 102.02 Current Rating | 102.08 Preparation and Delivery of Proposals |
| 102.13 Irregular Bid Proposals | 102.14 Disqualification of Bidders |
| 102.09 Proposal Guaranty | |

CIVIL RIGHTS ACT OF 1964

The Kentucky Department of Highways, in accordance with the provisions of Title VI of the Civil Rights Act of 1964 (78 Stat. 252) and the Regulations of the Federal Department of Transportation (49 C.F.R., Part 21), issued pursuant to such Act, hereby notifies all bidders that it will affirmatively insure that the contract entered into pursuant to this advertisement will be awarded to the lowest responsible bidder without discrimination on the ground of race, color, or national origin.

NOTICE TO ALL BIDDERS

To report bid rigging activities call: 1-800-424-9071.

The U.S. Department of Transportation (DOT) operates the above toll-free "hotline" Monday through Friday, 8:00 a.m. to 5:00 p.m. eastern time. Anyone with knowledge of possible bid rigging, bidder collusion, or other fraudulent activities should use the "hotline" to report such activities.

The "hotline" is part of the DOT's continuing effort to identify and investigate highway construction contract fraud and abuse and is operated under the direction of the DOT Inspector General. All information will be treated confidentially and caller anonymity will be respected.

SECOND TIER SUBCONTRACTS

Second Tier subcontracts on federally assisted projects shall be permitted. However, in the case of DBE's, second tier subcontracts will only be permitted where the other subcontractor is also a DBE. All second tier subcontracts shall have the consent of both the Contractor and the Engineer.

DISADVANTAGED BUSINESS ENTERPRISE PROGRAM

It is the policy of the Kentucky Transportation Cabinet (“the Cabinet”) that Disadvantaged Business Enterprises (“DBE”) shall have the opportunity to participate in the performance of highway construction projects financed in whole or in part by Federal Funds in order to create a level playing field for all businesses who wish to contract with the Cabinet. To that end, the Cabinet will comply with the regulations found in 49 CFR Part 26, and the definitions and requirements contained therein shall be adopted as if set out verbatim herein.

The Cabinet, contractors, subcontractors, and sub-recipients shall not discriminate on the basis of race, color, national origin, or sex in the performance of work performed pursuant to Cabinet contracts. The contractor shall carry out applicable requirements of 49 CFR 26 in the award and administration of federally assisted highway construction projects. The contractor will include this provision in all its subcontracts and supply agreements pertaining to contracts with the Cabinet.

Failure by the contractor to carry out these requirements is a material breach of its contract with the Cabinet, which may result in the termination of the contract or such other remedy as the Cabinet deems necessary.

DBE GOAL

The Disadvantaged Business Enterprise (DBE) goal established for this contract, as listed on the front page of the proposal, is the percentage of the total value of the contract.

The contractor shall exercise all necessary and reasonable steps to ensure that Disadvantaged Business Enterprises participate in a least the percent of the contract as set forth above as goals for this contract.

OBLIGATION OF CONTRACTORS

Each contractor prequalified to perform work on Cabinet projects shall designate and make known to the Cabinet a liaison officer who is assigned the responsibility of effectively administering and promoting an active program for utilization of DBEs.

If a formal goal has not been designated for the contract, all contractors are encouraged to consider DBEs for subcontract work as well as for the supply of material and services needed to perform this work.

Contractors are encouraged to use the services of banks owned and controlled by minorities and women.

CERTIFICATION OF CONTRACT GOAL

Contractors shall include the following certification in bids for projects for which a DBE goal has been established. BIDS SUBMITTED WHICH DO NOT INCLUDE CERTIFICATION OF DBE PARTICIPATION WILL NOT BE ACCEPTED. These bids will not be considered for award by the Cabinet and they will be returned to the bidder.

“The bidder certifies that it has secured participation by Disadvantaged Business Enterprises (“DBE”) in the amount of _____ percent of the total value of this contract and that the DBE participation is in compliance with the requirements of 49 CFR 26 and the policies of the Kentucky Transportation Cabinet pertaining to the DBE Program.”

The certification statement is located in the electronic bid file. All contractors must certify their DBE participation on that page. DBEs utilized in achieving the DBE goal must be certified and prequalified for the work items at the time the bid is submitted.

DBE PARTICIPATION PLAN

Lowest responsive bidders must submit the *DBE Plan/ Subcontractor Request*, form TC 14-35 DBE, within **5** days of the letting. This is necessary before the Awards Committee will review and make a recommendation. **The project will not be considered for award prior to submission and approval of the apparent low bidder’s DBE Plan/Subcontractor Request.**

The DBE Participation Plan shall include the following:

1. Name and address of DBE Subcontractor(s) and/or supplier(s) intended to be used in the proposed project;
2. Description of the work each is to perform including the work item, unit, quantity, unit price and total amount of the work to be performed by the individual DBE. The Proposal Line Number, Category Number, and the Project Line Number can be found in the “material listing” on the Construction Procurement website under the specific letting;
3. The dollar value of each proposed DBE subcontract and the percentage of total project contract value this represents. DBE participation may be counted as follows:
 - a. If DBE suppliers and manufactures assume actual and contractual responsibility, the dollar value of materials to be furnished will be counted toward the goal as follows:
 - The entire expenditure paid to a DBE manufacturer;
 - 60 percent of expenditures to DBE suppliers that are not manufacturers provided the supplier is a regular dealer in the product involved. A regular dealer must be engaged in, as its principal business and in its own name, the sale of products to the public, maintain an inventory and own and operate distribution equipment; and
 - The amount of fees or commissions charged by the DBE firms for a bona fide service, such as professional, technical, consultant, or managerial services and assistance in the procurement of essential personnel, facilities, equipment, materials, supplies, delivery of materials and supplies or for furnishing bonds, or insurance, providing such fees or commissions are determined to be reasonable and customary.

- b) The dollar value of services provided by DBEs such as quality control testing, equipment repair and maintenance, engineering, staking, etc.;
 - c) The dollar value of joint ventures. DBE credit for joint ventures will be limited to the dollar amount of the work actually performed by the DBE in the joint venture;
4. Written and signed documentation of the bidder's commitment to use a DBE contractor whose participation is being utilized to meet the DBE goal; and
 5. Written and signed confirmation from the DBE that it is participating in the contract as provided in the prime contractor's commitment.

UPON AWARD AND BEFORE A WORK ORDER WILL BE ISSUED

Contractors must submit the signed subcontract between the contractor and the DBE contractor, along with the DBE's certificate of insurance. If the DBE is a supplier of materials for the project, a signed purchase order must be submitted to the Division of Construction Procurement.

Changes to DBE Participation Plans must be approved by the Cabinet. The Cabinet may consider extenuating circumstances including, but not limited to, changes in the nature or scope of the project, the inability or unwillingness of a DBE to perform the work in accordance with the bid, and/or other circumstances beyond the control of the prime contractor.

CONSIDERATION OF GOOD FAITH EFFORTS REQUESTS

If the DBE participation submitted in the bid by the apparent lowest responsive bidder does not meet or exceed the DBE contract goal, the apparent lowest responsive bidder must submit a Good Faith Effort Package to satisfy the Cabinet that sufficient good faith efforts were made to meet the contract goals prior to submission of the bid. Efforts to increase the goal after bid submission will not be considered in justifying the good faith effort, unless the contractor can show that the proposed DBE was solicited prior to the letting date. DBEs utilized in achieving the DBE goal must be certified and prequalified for the work items at the time the bid is submitted. One complete set (hard copy along with an electronic copy) of this information must be received in the Division of Contract Procurement no later than 12:00 noon of the tenth calendar day after receipt of notification that they are the apparent low bidder.

Where the information submitted includes repetitious solicitation letters it will be acceptable to submit a sample representative letter along with a distribution list of the firms solicited. Documentation of DBE quotations shall be a part of the good faith effort submittal as necessary to demonstrate compliance with the factors listed below which the Cabinet considers in judging good faith efforts. This documentation may include written subcontractors' quotations, telephone log notations of verbal quotations, or other types of quotation documentation.

The Good Faith Effort Package shall include, but may not be limited to information showing evidence of the following:

1. Whether the bidder attended any pre-bid meetings that were scheduled by the Cabinet to inform DBEs of subcontracting opportunities;
2. Whether the bidder provided solicitations through all reasonable and available means;
3. Whether the bidder provided written notice to all DBEs listed in the DBE directory at the time of the letting who are prequalified in the areas of work that the bidder will be subcontracting;
4. Whether the bidder followed up initial solicitations of interest by contacting DBEs to determine with certainty whether they were interested. If a reasonable amount of DBEs within the targeted districts do not provide an intent to quote or no DBEs are prequalified in the subcontracted areas, the bidder must notify the Disadvantaged Enterprise Business Liaison Officer (DEBLO) in the Office of Civil Rights and Small Business Development to give notification of the bidder's inability to get DBE quotes;
5. Whether the bidder selected portions of the work to be performed by DBEs in order to increase the likelihood of meeting the contract goals. This includes, where appropriate, breaking out contract work items into economically feasible units to facilitate DBE participation, even when the prime contractor might otherwise perform these work items with its own forces;
6. Whether the bidder provided interested DBEs with adequate and timely information about the plans, specifications, and requirements of the contract;
7. Whether the bidder negotiated in good faith with interested DBEs not rejecting them as unqualified without sound reasons based on a thorough investigation of their capabilities. Any rejection should be so noted in writing with a description as to why an agreement could not be reached;
8. Whether quotations were received from interested DBE firms but were rejected as unacceptable without sound reasons why the quotations were considered unacceptable. The fact that the DBE firm's quotation for the work is not the lowest quotation received will not in itself be considered as a sound reason for rejecting the quotation as unacceptable. The fact that the bidder has the ability and/or desire to perform the contract work with its own forces will not be considered a sound reason for rejecting a DBE quote. Nothing in this provision shall be construed to require the bidder to accept unreasonable quotes in order to satisfy DBE goals;
9. Whether the bidder specifically negotiated with subcontractors to assume part of the responsibility to meet the contract DBE goal when the work to be subcontracted includes potential DBE participation;
10. Whether the bidder made any efforts and/or offered assistance to interested DBEs in obtaining the necessary equipment, supplies, materials, insurance and/or bonding to satisfy the work requirements of the bid proposal; and
11. Any other evidence that the bidder submits which may show that the bidder has made reasonable good faith efforts to include DBE participation.

FAILURE TO MEET GOOD FAITH REQUIREMENT

Where the apparent lowest responsive bidder fails to submit sufficient participation by DBE firms to meet the contract goal and upon a determination by the Good Faith Committee based upon the information submitted that the apparent lowest responsive bidder failed to make sufficient reasonable efforts to meet the contract goal, the bidder will be offered the opportunity to meet in person for administrative reconsideration. The bidder will be notified of the Committee's decision within 24 hours of its decision. The bidder will have 24 hours to request reconsideration of the Committee's decision. The reconsideration meeting will be held within two days of the receipt of a request by the bidder for reconsideration.

The request for reconsideration will be heard by the Office of the Secretary. The bidder will have the opportunity to present written documentation or argument concerning the issue of whether it met the goal or made an adequate good faith effort. The bidder will receive a written decision on the reconsideration explaining the basis for the finding that the bidder did or did not meet the goal or made adequate Good Faith efforts to do so.

The result of the reconsideration process is not administratively appealable to the Cabinet or to the United States Department of Transportation.

The Cabinet reserves the right to award the contract to the next lowest responsive bidder or to rebid the contract in the event that the contract is not awarded to the low bidder as the result of a failure to meet the good faith requirement.

SANCTIONS FOR FAILURE TO MEET DBE REQUIREMENTS OF THE PROJECT

Failure by the prime contractor to fulfill the DBE requirements of a project under contract or to demonstrate good faith efforts to meet the goal constitutes a breach of contract. When this occurs, the Cabinet will hold the prime contractor accountable, as would be the case with all other contract provisions. Therefore, the contractor's failure to carry out the DBE contract requirements shall constitute a breach of contract and as such the Cabinet reserves the right to exercise all administrative remedies at its disposal including, but not limited to the following:

- Disallow credit toward the DBE goal;
- Withholding progress payments;
- Withholding payment to the prime in an amount equal to the unmet portion of the contract goal; and/or
- Termination of the contract.

PROMPT PAYMENT

The prime contractor will be required to pay the DBE within seven (7) working days after he or she has received payment from the Kentucky Transportation Cabinet for work performed or materials furnished.

CONTRACTOR REPORTING

All contractors must keep detailed records and provide reports to the Cabinet on their progress in meeting the DBE requirement on any highway contract. These records may include, but shall not be limited to payroll, lease agreements, cancelled payroll checks, executed subcontracting agreements, etc. Prime contractors will be required to complete and submit a **signed and notarized** Affidavit of Subcontractor Payment (TC 18-7) and copies of checks for any monies paid to each DBE subcontractor or supplier utilized to meet a DBE goal. These documents must be completed and signed within 7 days of being paid by the Cabinet.

Payment information that needs to be reported includes date the payment is sent to the DBE, check number, Contract ID, amount of payment and the check date. Before Final Payment is made on this contract, the Prime Contractor will certify that all payments were made to the DBE subcontractor and/or DBE suppliers.

******* IMPORTANT *******

Please mail the original, signed and completed TC (18-7) Affidavit of Subcontractor Payment form and all copies of checks for payments listed above to the following address:

Office of Civil Rights and Small Business Development
6th Floor West 200 Mero Street
Frankfort, KY 40622

The prime contractor should notify the KYTC Office of Civil Rights and Small Business Development seven (7) days prior to DBE contractors commencing work on the project. The contact in this office is Mr. Melvin Bynes. Mr. Bynes' current contact information is email address – melvin.bynes2@ky.gov and the telephone number is (502) 564-3601.

DEFAULT OR DECERTIFICATION OF THE DBE

If the DBE subcontractor or supplier is decertified or defaults in the performance of its work, and the overall goal cannot be credited for the uncompleted work, the prime contractor may utilize a substitute DBE or elect to fulfill the DBE goal with another DBE on a different work item. If after exerting good faith effort in accordance with the Cabinet's Good Faith Effort policies and procedures, the prime contractor is unable to replace the DBE, then the unmet portion of the goal may be waived at the discretion of the Cabinet.

PROHIBITION ON TELECOMMUNICATIONS EQUIPMENT OR SERVICES

In accordance with the FY 2019 National Defense Authorization Act (NDAA), 2 CFR 200.216, and 2 CFR 200.471, Federal agencies are prohibited, after August 13, 2020, from obligating or expending financial assistance to obtain certain telecommunications and video surveillance services and equipment from specific producers. As a result of these regulations, contractors and subcontractors are prohibited, on projects with federal funding participation, from providing telecommunication or video surveillance equipment, services, or systems produced by:

- Huawei Technologies Company or ZTE Corporation (or any subsidiary or affiliate of such entities)
- Hytera Communications Corporation, Hangzhou Hikvision Digital Technology Company, or Dahua Technology Company (or any subsidiary or affiliate of such entities)

LEGAL REQUIREMENTS AND RESPONSIBILITY TO THE PUBLIC – CARGO PREFERENCE ACT (CPA).

(REV 12-17-15) (1-16)

SECTION 7 is expanded by the following new Article:

102.10 **Cargo Preference Act – Use of United States-flag vessels.**

Pursuant to Title 46CFR Part 381, the Contractor agrees

- To utilize privately owned United States-flag commercial vessels to ship at least 50 percent of the gross tonnage (computed separately for dry bulk carriers, dry cargo liners, and tankers) involved, whenever shipping any equipment, material, or commodities pursuant to this contract, to the extent such vessels are available at fair and reasonable rates for United States-flag commercial vessels.

- To furnish within 20 days following the date of loading for shipments originating within the United States or within 30 working days following the date of loading for shipments originating outside the United States, a legible copy of a rated, 'on-board' commercial ocean bill-of-lading in English for each shipment of cargo described in paragraph 1 of this section to both the Contracting Officer (through the prime contractor in the case of subcontractor bills-of-lading) and to the Division of National Cargo, Office of Market Development, Maritime Administration, Washington, DC 20590.

- To insert the substance of the provisions of this clause in all subcontracts issued pursuant to this contract.

EXPEDITE PROJECT WORK ORDER

The Contractor may request that the Department expedite the work order for this project to allow for maximization of time to complete the work. In order for the Department to accomplish this task, the Contractor may be required to “hand carry” all required project documentation to facilitate the process. Immediately UPON NOTIFICATION OF AWARD OF THE CONTRACT, deliver required project documentation to:

Division of Construction Procurement
200 Mero St.
Frankfort, KY 40602

**SPECIAL NOTES
DISTRICT NO. 6
KENTON COUNTY
BRIDGE CLEANING AND PAINTING
ITEM NO. 6-17.09 - NHPP IM 0758(107)
059GR21M007 - CID 212951**

FD52 059 0075 B00040N 191.25

Kenton County ~ I-75 over 3rd, 4th and 5th Streets (Kentucky Approach)

Geographic Coordinates

Latitude ~ 39° 05' 05.00'' (39.0868)

Longitude ~ -084° 31' 22.00'' (-84.5228)

Description

1200' Steel Approach Spans, Existing Drawing Nos. 14955, 20483 and 20483

FD52 059 0075 B00046N 191.54

Kenton County ~ I-75 over Ohio River (Main River Truss) Cleaning and Painting

Geographic Coordinates

Latitude ~ 39° 05' 26.00'' (39.0907)

Longitude ~ -084° 31' 21.00'' (-84.5226)

Description

1740' 3 Span Continuous Truss, Existing Drawing Nos. 14355, 14664 and 20950

FD52 059 0075 HAM-00071-0000L/R

Hamilton County ~ I-75 (Ohio Approach)

Geographic Coordinates

Latitude ~ 39° 05' 26.00'' (39.0907)

Longitude ~ -084° 31' 21.00'' (-84.5226)

Description

1740' Steel Spans. Existing Drawing No. HAM 25-0.04

SPECIAL NOTES FOR CLEANING AND PAINTING

SPECIAL NOTE FOR BIDDING PREQUALIFICATION AND STAFFING

SPECIAL NOTE BRIDGE CLEANING AND PAINTING

SPECIAL NOTE FOR UTILITIES AND SIGNS

SPECIAL NOTE FOR WEIGHT LIMITS ON STRUCTURE

SPECIAL NOTE FOR WORKING OVER OR FROM THE OHIO RIVER

SPECIAL NOTE FOR OHIO RIVER

SPECIAL NOTE FOR REPLACE TRAFFIC PROTECTION PANELS

SPECIAL NOTE FOR OVERHEAD TRAFFIC SIGN AND PAVEMENT
MARKING REPLACEMENT

SPECIAL NOTE FOR CONCRETE SEALING

SPECIAL NOTE FOR DECK DRAIN RETROFIT

SPECIAL NOTE FOR MAINTAINING AND CONTROLLING TRAFFIC

SPECIAL NOTE FOR CONTRACT COMPLETION DATE AND LIQUIDATED
DAMAGES ON BRIDGE REPAIR CONTRACTS

SPECIAL NOTE FOR PRE-BID CONFERENCE

SPECIAL NOTE FOR BIDDING PREQUALIFICATION AND STAFFING

Bidders must be Pre-qualified under **I18A – Bridge Painting** to have a bid opened and read.

The contractor must retain staff meeting the requirements listed below for the duration of this contract. Any production work conducted while not meeting these requirements is not eligible for payment. Company personnel must have been directly responsible for field operations of a bridge painting project;

1. Using abrasive blast surface preparation,
2. Full containment meeting industry standard SSPC Technology Guide No.6, Class 2A,
3. Involving thru-truss construction,
4. Over traffic, and
5. At least one thru-truss span length of 500 feet or greater.

The projects must have been completed to the facility owners' satisfaction.

The Contractor(s) and or Subcontractor(s) performing other operations required in this contract (not paint related) shall be Pre-qualified for appropriate work items.

SPECIAL NOTE BRIDGE CLEANING AND PAINTING

1. DESCRIPTION.

Perform all work in accordance with the Kentucky Transportation Cabinet, Department of Highway's Standard Specifications for Road and Bridge Construction and applicable Supplemental Specifications, the Standard Drawings, (current editions), this Note and Attached Detailed Drawings. Section references are to the Standard Specifications. This work consists of the following: (1) Furnish all labor, materials, tools, and equipment, (2) Cleaning and Painting and (3) Any other work specified as part of this contract.

2. CONSTRUCTION.

All structural steel shall be cleaned and painted in accordance with the Kentucky Transportation Cabinet, Department of Highways Standard Specifications for Road and Bridge Construction (current edition) Section 614.

All structural shall be Abrasive Blast Cleaned and Painted. See Section 614.03.09 for Abrasive Blast Cleaning and Painting.

3. RECYCABLE MATERIAL.

Contrary to Section 614.03.09 section 5 transport and recycling the Contractor shall send all recyclable debris and complete their supplier profile form to the recycler listed below instead of the supplier profile form from the Division of Construction's website given.

The recycler is: The Doe Run Company: Resource Recycling Division, HC1 Box 1395, HWY 10K, Boss, MO 65440, phone (573) 626-4813, fax (573) 626-3304, email www.doerun.com. The contractor will complete the Doe Run Supplier Profile Form and provide copies of it to both Doe Run and the Engineer prior to transporting the surface preparation debris.

4. GRAPHITE COATED BRONZE SLIDING CONNECTIONS.

The Contractor shall protect the graphite coating on the bronze sliding connections at panel points L17-U17 and L29-U29. Any graphite coating that is removed or damage must be replace at no additional cost to the department.

5. DAMAGE TO STRUCTURE.

The Contractor shall bear all responsibility and expense for any and all damage to the structure including the new concrete coatings during the painting work, even to the removal and replacement of a fallen span, should the fallen span result from the Contractors actions.

SPECIAL NOTE FOR UTILITIES AND SIGNS

All utilities (see below for electric), traffic signs, aviation lighting and navigation lighting shall be maintain and protected from damage.

All electric power that shall on the structure shall be de-energized. The Contractor shall coordinate with the Department to have the power de-energized.

SPECIAL NOTE FOR WEIGHT LIMITS ON STRUCTURE

059B00040N is rated at **53** tons.

059B00046N is rated at **43** tons.

HAM-00071-0000L/R is rated at **40** tons.

No equipment, materials, vehicles, trailers nor combination of thereof exceeding the load rating of each structure listed above shall be placed on or drive across the structure. If the Contractor chooses to stage from the bridge deck he must submit a plan for approval by the KYTC Engineer showing placement and weight of all equipment.

SPECIAL NOTE FOR WORKING OVER OR FROM THE OHIO RIVER

A minimum level of 3'-0" below low steel shall be maintain. The Contractor shall contact the US Coast Guard and have their work plan approved before any work on the bridge commences.

Contact:

Giselle MacDonald
Bridge Management Specialist
Eighth Coast Guard District
St. Louis, MO 63103
314-269-2379
Giselle.T.MacDonald@uscg.mil

If any work is conducted from a barge or other vessel on the Ohio River, the contractor is solely responsible for compliance with all regulatory, statutory, and insurance requirements thus applicable. Agencies involved include but are not limited to The US Army Corp of Engineers and the US Coast Guard. The Department assumes no obligations or liabilities for work stoppages due to enforcement actions by government regulatory agencies or to related delays that the Department deems necessary.

SPECIAL NOTE FOR OHIO RIVER

**Prevent Materials and Debris Generated by the Project from Entering the
Ohio River**

**Kenton County
BRENT SPENCE BRIDGE PROJECT (ADDITIONAL PROJECT FUNDS
FOR MAINTENANCE, REPAIR AND PAINTING).**

Item No. 6-17.09

NO EFFECTS TO THE OHIO RIVER DUE TO CONSTRUCTION.

**If there are any questions regarding this note, please contact Danny Peake,
Director, Division of Environmental Analysis, 200 Mero Street, Frankfort, KY
40601, Phone: (502) 564-7250.**

SPECIAL NOTE FOR REPLACE TRAFFIC PROTECTION PANELS

1. DESCRIPTION.

Perform all work in accordance with the Kentucky Transportation Cabinet, Department of Highway's Standard Specifications for Road and Bridge Construction and applicable Supplemental Specifications, the Standard Drawings, (current editions), this Note and Attached Detailed Drawings. Section references are to the Standard Specifications. This work consists of the following: (1) Furnish all labor, materials, tools, and equipment, (2) Remove and replace all traffic protection and (3) Any other work specified as part of this contract.

2. MATERIALS.

- A. Wood.** All wood used for the traffic protection panels shall be marine grade.
- B. Square Tubing.** Square tubing shall conform to ASTM A 513.
- C. Chain Link Fence Fabric.** Chain link fabric shall conform to ASTM A 392.
- D. Fence Fittings and Hardware.** Fence fittings and hardware shall conform to ASTM F 626.
- E. Bolts.** Bolts shall conform to ASTM F 1554 Grade 36. Nuts and washers must be in accordance with Section 813.
- F. Coatings.** All lag screws for wood and chain link fence components shall be galvanized conforming to ASTM A 123 or ASTM A 153 as applicable.

3. CONSTRUCTION.

- A. Location.** Traffic protection constructed of wood panels are in place on the north approach spans over north bound traffic.
- B. Removal.** Remove all existing wood panels to access for all cleaning and painting operations. Dispose of all removed material entirely away from the job site. This work shall be incidental to the unit price bid "Square Foot" for Replace Traffic Protection Panels.
- C. Replacement.** Replace all traffic protection panels as specified in this special note and the attached detailed drawings after all cleaning and painting operations are complete. New chain link fence panels shall be used though out the spans. Wood panels shall be used at intermediate cross frame location and deck drains to facilitate construction. See attached detailed drawings for locations of each.
- D. Furnishing and Fabricating.** Construct the panels following this note and attached detailed drawings. Ensure shop welders, welding operators, welding equipment, and welding procedures are qualified in accordance with AWS D1.1, Structural Welding Code – Steel, as modified by the contract. American Institute of Steel Construction (AISC) certification is not required for the steel fabrication work. Ensure all materials are hot-dipped galvanized in accordance with ASTM A 123 or ASTM A 153, as applicable. Ensure all welded members are hot-dipped galvanized after welding is complete.
Fabricate the steel frame using 2 inch, 11 gauge square tubing. The length of panel varies and is determined from the bridge beam spacing. The maximum allowable length is 9 feet. The panel length can be determined by measuring the beam web to web distance and subtracting 2 inches.

Use 9 gauge wire with 1 inch openings for the chain link fabric. Tension with 1/2 inch - 9 gauge flat stock steel bars, attached to tube frame with 11 gauge steel clamps and 5/8 inch galvanized bolts, washers, and nuts.

Shipping and Installing. Transport and unload panels without damage. Install panels between the beam lines and adjacent to any web stiffeners as directed by the Engineer.

- E. Residual Lead.** Residual lead paint may still be on bridge. The Contractor is advised to take all necessary protective measures including worker safety and environmental regulations when performing surface preparation and other work. The Department will not consider any claims based on residual lead paint.
- F. Verifying Field Conditions.** The Contractor shall field verify dimensions and locations before ordering any material. New material that is unsuitable due to variation in existing structure shall be replaced at the Contractors expense.
- G. Damage to the structure.** The Contractor shall bear all responsibility and expense for any and all damage to the structure during the repair work, even to the removal and replacement of a fallen span, should the fallen span result from the Contractors actions.

4. MEASUREMENT.

A. Replace Traffic Protection Panels.

The Department will measure the quantity in Square Feet.

5. PAYMENT.

A. Replace Traffic Protection Panels (26118EC).

Payment at the contract unit price for "Square Feet" is full compensation for furnishing and installing all material as specified.

SPECIAL NOTE FOR OVERHEAD PANEL SIGN AND PAVEMENT MARKING REPLACEMENT

1. DESCRIPTION.

Perform all work in accordance with the Kentucky Transportation Cabinet, Department of Highway's Standard Specifications for Road and Bridge Construction and applicable Supplemental Specifications, the Standard Drawings, (current editions), this Note, Attached Detailed Drawings, Standard Highway Signs and Manual on Uniform Traffic Control Devices - Federal Highway Administration (current editions). Section references are to the Standard Specifications. This work consists of the following: (1) Furnish all labor, materials, tools, and equipment, (2) Remove and replace all traffic signage as specified and (3) Any other work specified as part of this contract.

2. MATERIALS.

- A. Sign Substrates and Sheeting.** Sign substrates and Sheeting shall conform to Section 830 and 833. Only sheeting on the department's list of approved material shall be used.
- B. Retroreflective Materials.** All retroreflective materials shall be fabricated assembled with manufacturer's specification and/or recommendations.
- C. Signs and Components.** Signs and components shall be fabricated using type XI sheeting.
- D. Letters, Symbols and Borders.** Letters, symbols and border shall be direct applied in accordance with manufacture's guidance.
- E. Hardware.** All hardware for the assembly of panel signs and the attachment of these signs shall be as recommended by the panel manufacturer. All hardware for erection of sheeting signs shall be cadmium plated steel in accordance with ASTM B776 and ASTM A-307.
- F. Fonts.** Standard alphabets shall be used for all legends on panel guide signs.
- G. Preformed Thermoplastic.** Thermoplastic shall conform to Section 717.

3. CONSTRUCTION~PANEL SIGNS.

- A. Location.** Overhead Traffic signs are located at 4 different locations on the main river truss. See attached detailed drawings for location.
- B. Removal.** Remove overhead traffic signs before cleaning and painting operations commence. Overhead Traffic Signs located at L11-U11 have recently been replaced. After removing these the Contractor shall store them at location determined by the Engineer. Cost remove and store shall be incidental to unit price bid for Panel Signs. Dispose of all removed material entirely away from the job site. Existing floor beam mounting brackets to remain for re-use. This work shall be considered incidental to the unit price bid "Square Foot" for Panel Signs.
- C. Replacement.** Replace all overhead traffic signs new as specified in this special note and the attached detailed drawings after all cleaning and painting operations are complete. The panel signs at L11-U11 shall be reinstalled after painting operation in this area is complete. Cost to reinstall the existing panel signs shall be incidental to the unit price bid for Panel Signs. Existing floor beam mounting brackets will be re-used for mounting the new overhead traffic signs.

D. Furnishing and Fabricating. Construct the panels following this note and attached detailed drawings.

4. CONSTRUCTION~PAVEMENT MARKINGS.

A. Location. Pavement Markings are located at 4 different locations on the main river truss. See attached detailed drawings for location.

B. Removal. Remove existing pavement marking in accordance with Section 717. Dispose of all removed material entirely away from the job site. This work shall be considered incidental to the unit price bid “Each” for Pavement Marking-Thermo Elong Route Shield.

C. Replacement. Replace all pavement markings as specified in this special note, the attached detailed drawings, Section 717 and MUTCD Section 32B-25.

5. MEASUREMENT.

A. Panel Signs.

The Department will measure the quantity in Square Feet.

B. Pave Marking-Thermo Elong Route Shield.

The Department will measure the quantity as Each.

6. PAYMENT.

A. Panel Signs (06405).

Payment at the contract unit price for “Square Feet” is full compensation for furnishing and installing all overhead traffic signs and necessary hardware to attach as specified.

B. Pave Marking-Thermo Elong Route Shield. (24899EC).

Payment at the contract unit price for “Each” is full compensation for removing existing pavement markers and installing new pavement markers as specified in the is contract.

SPECIAL NOTE FOR CONCRETE SEALING

1. **DESCRIPTION.** Perform all work in accordance with the Kentucky Transportation Cabinet, Department of Highway's 2019 Standard Specification for Road and Bridge Construction applicable Supplemental Specifications, Standard Drawings, this Note Section references are to the Standard Specifications. This work consists of the following: (1) Furnish all labor, materials, tools, and equipment.

2. **MATERIALS.**
 - A. **Concrete Sealant (Bridge Barrier Wall)**

Product	Supplier
Protectosil BHN	Evonik Industries
Protectosil 300	Evonik Industries
TK-590-40 Tri-Silane 40%	TK Products
Certivex Penseal 244 O/W 80	Vexcon
Master Protect H 440 VT (formerly Hydrozo Clear 40 VOC)	BASF
SW-244-100 DOT	Chemical Products Industries, Inc.
TK-590-1 MS Tri-Silane	TK Products

3. **CONSTRUCTION.**
 - A. **Seal Concrete on the barrier walls between panel points L17-U17 and L19-L19 NB lower deck and between panel points L16-U16 and L20-L21 SB upper Deck. See attached detailed drawings.**

Clean Concrete. Dry clean concrete surfaces to remove all loose debris. Remove all visible hydrocarbons from the surface with detergent approved by the manufacturer of the deck sealant. Pressure wash all surfaces to be sealed at 2000 to 3000 psi. Install pressure gauges at each wand to verify pressure. Use 30° fan tip or as recommended by the manufacturer of the deck sealant. Hold pressure washing wand a minimum of 45° from the deck with a maximum stand-off distance of 12 inches. This includes the entire surface area of the bridge deck, interior faces and top of parapet walls including the end bent/abutment wing walls.

Seal Concrete. All concrete to be sealed must be clean and dry. Monitor weather conditions prior to sealer application. Refer to the manufacturer's recommendations for proper ambient conditions. Do not apply sealer if precipitation is anticipated within the time stated by the manufacturer. Allow the deck to dry 24 hours (after washing or rain event) before sealer application. The deck can be reopened to traffic while drying. Sealer must be applied within 48 hours of washing or the deck must be rewashed. Divide the deck into predefined areas of specific square footage to aid in determining usage. Comply with manufacturer's usage recommendation. Using a low pressure pump, apply sealer and spread evenly with broom or squeegee; do not allow pooling to remain. When each predefined area is complete, measure the amount of sealer used to verify proper usage. After sealing, follow manufacturer's recommended cure time before opening to traffic. This includes the entire surface area of the bridge deck, interior faces and top of parapet walls including the end bent/abutment wing walls.

4. MEASUREMENT.

Concrete Sealing. The Department will measure the quantity per square feet of each area restored completed and accepted.

5. PAYMENT.

Concrete Sealing (23378EC). Payment at the contract unit price for Square Foot is full compensation for the following: (1) Furnish all labor, materials, tools, and equipment; (2) Clean existing concrete; (3) Seal the existing concrete; and, (4) Any other work specified as part of this contract.

SPECIAL NOTE FOR DECK DRAIN RETROFIT

1. DESCRIPTION. Perform all work in accordance with the Kentucky Transportation Cabinet, Department of Highway's Standard Specifications for Road and Bridge Construction and applicable Supplemental Specifications, the Standard Drawings, (Current Additions), this note, and the attached detail drawings. This work consists of: (1) Furnish all labor, materials, tools, and equipment; (2) Install Deck Drain Retrofit and (3) Any other work specified as part of this contract.

1. MATERIALS

A. See attached detailed drawings.

3. CONSTRUCTION

A. See attached detailed drawings.

4. MEASUREMENT

A. Deck Drain Retrofit. The Department will measure this quantity as each.

5. PAYMENT

A. Deck Drain Retrofit (24692EC). Payment at the contract unit price per each is full compensation for furnishing and installing the deck drain retrofit as specified by this note and as shown on the attached detail drawings.

SPECIAL NOTE FOR MAINTAIN AND CONTROL TRAFFIC

All lane closures on this project shall be in accordance with Kentucky Department of Highways Standard Drawings No. **TTC-115, TTC-120, TTC-125, TTD 120 and the FHWA Manual for Uniform Traffic Control Devices (current editions) unless otherwise specified.** Lane closures should be used only when absolutely necessary and kept to the shortest duration possible in order to minimize disruption to the traveling public. No work will be conducted over unprotected traffic at any location. At the discretion of the Engineer, lane closures may be restricted on holiday weekends. The contractor must submit a traffic control plan for review and approval by the KYTC Engineer 14 days prior to the Pre-Construction Conference.

1. EMERGENCY REPAIRS AND COORDINATION WITH OTHER CONTRACTS

In the event it becomes necessary to make emergency repairs at this project by state forces or by other outside contractors, the (painting) contractor agrees to alter his work pattern as directed by the engineer so as not to interfere with the emergency work. The contractor shall be required to coordinate his efforts with those of any other contractor in the construction area.

2. TRAFFIC CONTROL DEVICES

The contractor will be required to furnish all traffic control devices whenever his operations endanger or interfere with vehicular traffic as determined by the engineer. The contractor shall furnish any additional traffic control devices necessary to protect traffic and his workmen. Any costs associated with the added traffic control devices (including arrow boards) shall be incidental to the contract lump sum amount for "maintain and control traffic." Placement of all devices for lane closures shall start and proceed in the direction of flow of traffic. Removal of devices shall start at the end of the construction area and proceed toward oncoming traffic. The contractor shall provide for the installation of all necessary traffic control devices before beginning work and their immediate removal as soon as work is suspended or completed. During the fully operational periods, when no lane closures are permitted, all equipment shall be totally removed from the job site. Traffic control signs shall be removed or covered if lane closure is not in place.

3. VEHICLES

The contractor's vehicles shall always move with and not across or against the flow of traffic. Vehicles shall enter or leave work areas in a manner that will not be hazardous to or interfere with normal roadway traffic. Vehicles shall not park or stop except within designated work areas.

Personal vehicles will not be permitted to park within the state right-of-way. The contractor's vehicles will be prohibited from crossing the roadway and all pedestrian movement of the contractor's personnel on the roadway will be limited to within the closed work areas.

4. POLICE OFFICER WITH VEHICLE

A "police officer with vehicle" will be used for installation of and removal of all lane closures and deployment of rolling roadblocks. The Contractor will be responsible for all coordination with the local law enforcement and the KYTC engineer. Payment for this item will be included in the lump sum bid for Maintain and Control Traffic.

5. TRUCK MOUNTED ATTENUATOR

Any lane or shoulder closure will include the use of a Truck Mounted Attenuator placed between oncoming traffic and equipment or vehicles.

6. MINIMUM VERTICAL AND HORIZONTAL CLEARANCES

A minimum vertical clearance of 16'-6" shall be maintained for any rigging and containment materials left in place above traffic. This minimum vertical clearance must be signed. The Contractor shall notify the following for height and width restrictions when any rigging and containment is in place with minimal clearance:

Kentucky Transportation Cabinet's Department of Motor Carriers Oversize Permits Section:

<https://drive.ky.gov/motor-carriers/Pages/OWOD-Services.aspx>

Ohio Department of Transportation's Special Hauling Permits Section:

<http://www.dot.state.oh.us/Divisions/Operations/Maintenance/Permits/Pages/default.aspx>

6. ROLLING ROAD BLOCKS

Rolling roadblocks will be permitted during the hours 12:00 AM to 4:00 AM for rigging and containment installation/removal. When using rolling road blocks the Contractor shall employ one vehicle per lane including ramps as necessary, in one direction at a predetermined time and predetermined speed as directed by the Engineer. There shall be no stopping of the rolling roadblock. Prior to instituting such the roadway ahead shall be cleared of traffic as directed by the Engineer. The area of influence shall be sealed off (all on-ramps or access intersection closed) by use of flaggers and or Contractor's vehicles. The purpose is to seal off a certain work area and/or work function as designated in the notes so that the Contractor can perform certain work without any hazard to traffic. The rolling roadblock shall prevent any other vehicles at a slower speed than normal and forcing all vehicles to follow behind the Contractor's vehicles at their predetermined speed. Rolling roadblock will be used during specified hours for each bridge as directed by the Engineer. See links below for additional requirements.

Kentucky Transportation Cabinet's Permits Branch:

Form-TC 99-210 Rolling Road Block for Permitted Work Full Controlled Highways

<https://transportation.ky.gov/OrganizationalResources/Forms/TC%2099-210.pdf>

Ohio Department of Transportation's Roadway Design:

http://www.dot.state.oh.us/Divisions/Engineering/Roadway/DesignStandards/traffic/SCD/Documentation/MT_09960_2016-07-15.pdf

7. STAGING IN RIGHT OF WAY AREAS

The Contractor shall be responsible for any base material to park equipment on in right of way areas. This material must be removed and site restored to original condition as directed by the Engineer upon completion of the project. Right of Way areas on the Kentucky side of the bridge have lessees using the property. The occupants will have vacate the leased area by terms of lease agreement with the Kentucky Transportation Cabinet. The Contractor shall give the occupants a 30 calendar day notice of when their operation will affect the leased area to allow ample time for the occupants to temporarily relocate.

8. TEMPORARY CONCTETE BARRIERS

All lane closures specified shall require temporary Concrete Barriers 9t (**NO ALTERNATIVES ALLOWED**) shall be used to protect work area in the shoulder closure and the median clear zones. All temporary barrier for shoulder closures shall be use in accordance with Standard Drawing TTC-120 C.E. All other applications of temporary barrier shall use required end treatment. If median cable barrier is present the temporary concrete barrier will not be required. Temporary Concrete Barriers shall remain the Contractor's property and shall be removed from the construction site upon completion of construction. Cost of temporary concrete barrier 9t shall be considered incidental to the "Lump Sum Bid for Maintain and Control Traffic.

9. VEHICULAR PLATFORM USE

Should the use any vehicular platform methods and equipment to complete work with specified maintenance of traffic, the Contractor must submit their deployment plan to the using vehicular platform with the required traffic control plan submittal.

10. MISC.

The Contractor shall reduce the speed limit to **45 MPH** in areas signed for 55 MPH.

The use of Double Fine Zones may be used at the Contractor's discretion.

The Engineer may elect to use Variable Message Boards when necessary.

11. NARRITIVE

Maintain two usable 11 foot minimum lanes of North Bound I-71/I-75 and South Bound I-75 at all times in each direction. Ramp closure for the KY 8 on ramp will be permitted. South Bound I-71 traffic will be detoured to South Bound I-471 for the duration of the project. See South Bound I-71 South Bound detour plans.

Maintain one 12 foot minimum lane for all work over KY 8 (Forth Street) and Fifth Street. Single temporary lane closures for rigging containment installation will be permitted over Third Street (KY approach), West Mehring Way and Augusta Street (OH approach).

12. MEASUREMENT.

A. Maintain and Control Traffic: The Department will measure the quantity as "Lump Sum".

B. Portable Changeable Message Sign: The Department will measure the quantity for "Each".

13. PAYMENT.

A. Maintain and Control Traffic (02650): Payment of the contract lump sum amount for "maintain and control traffic" shall be full compensation for all items necessary to maintain and control traffic as specified for this project. All traffic control items shall remain the property of the contractor when the work is complete.

B. Portable Changeable Message Sign (02671): Payment at "each" shall be full compensation to furnish, install, maintain and remove all portable message signs as specified.

**SPECIAL NOTE FOR CONTRACT COMPLETION DATE AND
LIQUIDATED DAMAGES ON BRIDGE REPAIR CONTRACTS**

- I. COMPLETION DATE.** The Contractor has the option of selecting the starting date for this Contract. Once selected, notify the Department in writing of the date selected at least two weeks prior to beginning work. All work is to be completed by November 15, 2021. The bridge shall be completely open to traffic by November 15, 2021.

- II. LIQUIDATED DAMAGES.** Contrary to the Liquidated Damages amounts specified in the Transportation Cabinet, Department of Highway's 2019 Standard Specifications for Road and Bridge Construction, Section 108.09, the Liquidated Damages for this project shall be \$10,000/day for each day after November 15, 2021.

All construction must be completed in accordance with the weather limitations specified in Section 606 and/or Section 601 as applicable. No extension of Contract time will be granted due to inclement weather or temperature limitations that occur due to starting work on the Contract or a structure late in the construction season.



KENTUCKY TRANSPORTATION CABINET
Department of Highways
DIVISION OF RIGHT OF WAY & UTILITIES

TC 62-226
Rev. 01/2016
Page 1 of 1

RIGHT OF WAY CERTIFICATION

<input checked="" type="checkbox"/> Original	<input type="checkbox"/> Re-Certification	RIGHT OF WAY CERTIFICATION	
--	---	-----------------------------------	--

ITEM #	COUNTY	PROJECT # (STATE)	PROJECT # (FEDERAL)
6-17.09	Kenton	FD52 059 0075 B00046N 191.54	NHPP IM 0758(107)

PROJECT DESCRIPTION

Maintenance, Repair, and Painting of the Brent Spence Bridge

No Additional Right of Way Required

Construction will be within the limits of the existing right of way. The right of way was acquired in accordance to FHWA regulations under the Uniform Relocation Assistance and Real Property Acquisitions Policy Act of 1970, as amended. No additional right of way or relocation assistance were required for this project.

Condition # 1 (Additional Right of Way Required and Cleared)

All necessary right of way, including control of access rights when applicable, have been acquired including legal and physical possession. Trial or appeal of cases may be pending in court but legal possession has been obtained. There may be some improvements remaining on the right-of-way, but all occupants have vacated the lands and improvements, and KYTC has physical possession and the rights to remove, salvage, or demolish all improvements and enter on all land. Just Compensation has been paid or deposited with the court. All relocations have been relocated to decent, safe, and sanitary housing or that KYTC has made available to displaced persons adequate replacement housing in accordance with the provisions of the current FHWA directive.

Condition # 2 (Additional Right of Way Required with Exception)

The right of way has not been fully acquired, the right to occupy and to use all rights-of-way required for the proper execution of the project has been acquired. Some parcels may be pending in court and on other parcels full legal possession has not been obtained, but right of entry has been obtained, the occupants of all lands and improvements have vacated, and KYTC has physical possession and right to remove, salvage, or demolish all improvements. Just Compensation has been paid or deposited with the court for most parcels. Just Compensation for all pending parcels will be paid or deposited with the court prior to AWARD of construction contract

Condition # 3 (Additional Right of Way Required with Exception)

The acquisition or right of occupancy and use of a few remaining parcels are not complete and/or some parcels still have occupants. All remaining occupants have had replacement housing made available to them in accordance with 49 CFR 24.204. KYTC is hereby requesting authorization to advertise this project for bids and to proceed with bid letting even though the necessary right of way will not be fully acquired, and/or some occupants will not be relocated, and/or the just compensation will not be paid or deposited with the court for some parcels until after bid letting. KYTC will fully meet all the requirements outlined in 23 CFR 635.309(c)(3) and 49 CFR 24.102(j) and will expedite completion of all acquisitions, relocations, and full payments after bid letting and prior to AWARD of the construction contract or force account construction.

Total Number of Parcels on Project	EXCEPTION (S) Parcel #	ANTICIPATED DATE OF POSSESSION WITH EXPLANATION
Number of Parcels That Have Been Acquired		
Signed Deed		
Condemnation		
Signed ROE		

Notes/ Comments (Use Additional Sheet if necessary)

LPA RW Project Manager		Right of Way Supervisor	
Printed Name		Printed Name	Lynn Whalen
Signature		Signature	<i>Lynn Whalen</i> Date: 2020.09.29
Date		Date	08:34:35 -04'00'
Right of Way Director		FHWA	
Printed Name		Printed Name	
Signature	<i>DM Loy</i> Digitally signed by DM Loy Date: 2020.09.29 09:00:36 -04'00'	Signature	
Date		Date	

UTILITIES AND RAIL CERTIFICATION NOTE

**Kenton County
NHPP IM 0758(107)
FD52 059 0075 B00046N
I-71/I-75 MILEPOINT 191.277 TO 191.777
REPAIRS, PAINTING, FALSEWORK REPLACEMENT AND OVERHEAD SIGN
REPLACEMENT TO THE BRENT SPENCE BRIDGE OVER THE OHIO RIVER
ITEM NUMBER: 06-17.09**

PROJECT NOTES ON UTILITIES

Utility coordination efforts determined that no utility owner relocation work is required to complete the project since no utilities owned by utility companies have been found to be in conflict with the work to be performed.

There are bundled primary electric cables suspended on poles under the Covington side approach immediately near the south side of the Covington floodwall. This cable bundle is intended to remain in place during the bridge work. Work by the contractor in the vicinity of this cable shall be coordinated with Duke Energy. Any cost for providing any special worker protection will be the responsibility of the contractor. A Duke Energy contact will be provided to the winning contractor at the preconstruction conference.

There are a few electric service drops viewed alongside of the Cincinnati approach. Work by the contractor in the vicinity of these drops shall be coordinated with Duke Energy. Any cost for providing any special worker protection will be the responsibility of the contractor. A Duke Energy contact will be provided to the winning contractor at the preconstruction conference.

Should there be unknown utilities found during construction, the Contractor is fully responsible for protection of those utilities. All discovered utilities should be reported to the KYTC engineer in charge for any needed follow-up.

NOTE: DO NOT DISTURB THE FOLLOWING FACILITIES LOCATED WITHIN THE PROJECT DISTURB LIMITS

There are no utility provider owned utilities known to be in conflict with the project.

THE FOLLOWING FACILITY OWNERS ARE RELOCATING/ADJUSTING THEIR FACILITIES WITHIN THE PROJECT LIMITS AND WILL BE COMPLETE PRIOR TO CONSTRUCTION

Not Applicable

UTILITIES AND RAIL CERTIFICATION NOTE

Kenton County
NHPP IM 0758(107)
FD52 059 0075 B00046N
I-71/I-75 MILEPOINT 191.277 TO 191.777
REPAIRS, PAINTING, FALSEWORK REPLACEMENT AND OVERHEAD SIGN
REPLACEMENT TO THE BRENT SPENCE BRIDGE OVER THE OHIO RIVER
ITEM NUMBER: 06-17.09

THE FOLLOWING FACILITY OWNERS HAVE FACILITIES TO BE RELOCATED/ADJUSTED BY THE OWNER OR THEIR CONTRACTOR AND IS TO BE COORDINATED WITH THE ROAD CONTRACT

Not Applicable

THE FOLLOWING FACILITY OWNERS HAVE FACILITIES TO BE RELOCATED/ADJUSTED BY THE CONTRACTOR AS INCLUDED IN THIS CONTRACT

Not Applicable

RAIL COMPANIES HAVE FACILITIES IN CONJUNCTION WITH THIS PROJECT AS NOTED

No Rail Involvement
 Rail Involved
 Rail Adjacent

AREA FACILITY OWNER CONTACT LIST

Facility Owner	Address	Contact Name	Phone	Email
Various	Contact information will be provided at the preconstruction meeting.			

THE FOLLOWING RAIL COMPANIES HAVE FACILITIES IN CONJUNCTION WITH THIS PROJECT AS NOTED

No Rail Involved
 Minimal Rail Involved (See Below)
 Rail Involved (See Below)

UTILITIES AND RAIL CERTIFICATION NOTE

Kenton County
NHPP IM 0758(107)
FD52 059 0075 B00046N
I-71/I-75 MILEPOINT 191.277 TO 191.777
REPAIRS, PAINTING, FALSEWORK REPLACEMENT AND OVERHEAD SIGN
REPLACEMENT TO THE BRENT SPENCE BRIDGE OVER THE OHIO RIVER
ITEM NUMBER: 06-17.09

SPECIAL CAUTION NOTE – PROTECTION OF UTILITIES

The contractor will be responsible for contacting all utility facility owners on the subject project to coordinate his activities. The contractor will coordinate his activities to minimize and, where possible, avoid conflicts with utility facilities. Due to the nature of the work proposed, it is unlikely to conflict with the existing utilities beyond minor facility adjustments. Where conflicts with utility facilities are unavoidable, the contractor will coordinate any necessary relocation work with the facility owner and Resident Engineer. The Kentucky Transportation Cabinet maintains the right to remove or alter portions of this contract if a utility conflict occurs.

The utility facilities as noted in the previous section(s) have been determined using data garnered by varied means and with varying degrees of accuracy: from the facility owners, a result of S.U.E., field inspections, and/or reviews of record drawings. The facilities defined may not be inclusive of all utilities in the project scope and are not Level A quality, unless specified as such. It is the contractor's responsibility to verify all utilities and their respective locations before excavating.

BEFORE YOU DIG

The contractor is instructed to call 1-800-752-6007 to reach KY 811, the one-call system for information on the location of existing underground utilities. The call is to be placed a minimum of two (2) and no more than ten (10) business days prior to excavation. The contractor should be aware that owners of underground facilities are not required to be members of the KY 811 one-call Before-U-Dig (BUD) service. The contractor must coordinate excavation with the utility owners, including those whom do not subscribe to KY 811. It may be necessary for the contractor to contact the County Court Clerk to determine what utility companies have facilities in the area.

Please Note: The information presented in this Utility Certification is informational and not guaranteed.

UTILITIES AND RAIL CERTIFICATION NOTE

**Kenton County
NHPP IM 0758(107)
FD52 059 0075 B00046N
I-71/I-75 MILEPOINT 191.277 TO 191.777
REPAIRS, PAINTING, FALSEWORK REPLACEMENT AND OVERHEAD SIGN
REPLACEMENT TO THE BRENT SPENCE BRIDGE OVER THE OHIO RIVER
ITEM NUMBER: 06-17.09**

MATERIAL SUMMARY

CONTRACT ID: 212955

059GR21M007 - NHPP

MB05900752101

LEXINGTON-CINCINNATI ROAD (I-71/I-75) BRENT SPENCE BRIDGE (059B00040N) OVER OHIO RIVER, KENTUCKY APPROACH AT MP 191.25. BRIDGE PAINTING & CLEANING.

Project Line No	Bid Code	DESCRIPTION	Quantity	Unit
0005	02650	MAINTAIN & CONTROL TRAFFIC - - 059B00040N	1.00	LS
0010	02671	PORTABLE CHANGEABLE MESSAGE SIGN - - 059B00040N	2.00	EACH
0015	08434	CLEAN & PAINT STRUCTURAL STEEL - - 059B00040N	1.00	LS
0020	02568	MOBILIZATION	1.00	LS
0025	02569	DEMOBILIZATION	1.00	LS

CONTRACT ID: 212955

059GR21M007 - NHPP

MB05900752102

LEXINGTON-CINCINNATI ROAD (I-71/I-75) BRENT SPENCE BRIDGE (059B00046N) OVER OHIO RIVER, MAIN RIVER TRUSS AT MP 191.25. BRIDGE PAINTING & CLEANING.

Project Line No	Bid Code	DESCRIPTION	Quantity	Unit
0030	02650	MAINTAIN & CONTROL TRAFFIC - - 056B00046N	1.00	LS
0035	02671	PORTABLE CHANGEABLE MESSAGE SIGN - - 059B00046N	2.00	EACH
0040	06405	SBM ALUMINUM PANEL SIGNS - - 059B00046N	540.00	SQFT
0045	08434	CLEAN & PAINT STRUCTURAL STEEL - - 059B00046N	1.00	LS
0050	23378EC	CONCRETE SEALING - - 059B00046N	3,000.00	SQFT
0055	24692EC	DECK DRAIN RETROFIT - - 059B00046N	1.00	EACH
0060	24899EC	PAVE MARKING-THERMO ELONG ROUTE SHIELD - - 059B00046N	16.00	EACH
0065	02568	MOBILIZATION	1.00	LS
0070	02569	DEMOBILIZATION	1.00	LS

MATERIAL SUMMARY

CONTRACT ID: 212955

059GR21M007 - NHPP

MB05900752103

LEXINGTON-CINCINNATI ROAD (I-71/I-75) BRENT SPENCE BRIDGE (HAM-0071-000L/R) OVER OHIO RIVER,
OHIO APPROACH AT MP 191.25. BRIDGE PAINTING & CLEANING.

Project Line No	Bid Code	DESCRIPTION	Quantity	Unit
0075	02650	MAINTAIN & CONTROL TRAFFIC - - 059B00046N	1.00	LS
0080	02671	PORTABLE CHANGEABLE MESSAGE SIGN - - 059B00046N	2.00	EACH
0085	08434	CLEAN & PAINT STRUCTURAL STEEL - - 059B00046N	1.00	LS
0090	26118EC	REPLACE TRAFFIC PROTECTION - - 059B00046N	31,900.00	SQFT
0095	02568	MOBILIZATION	1.00	LS
0100	02569	DEMOBILIZATION	1.00	LS

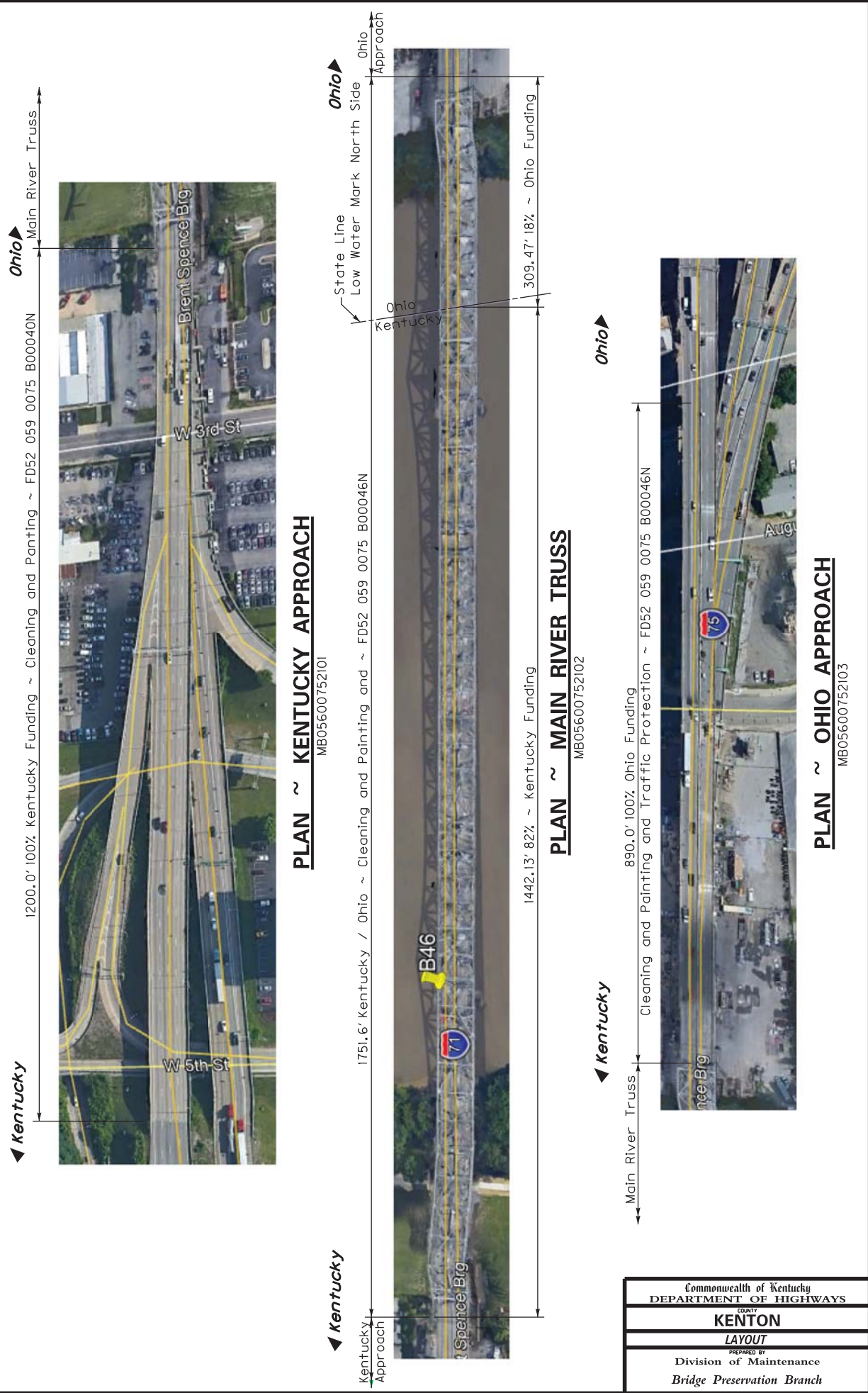

PLAN ~ KENTUCKY APPROACH
MB05600752101

PLAN ~ MAIN RIVER TRUSS
MB05600752102

PLAN ~ OHIO APPROACH
MB05600752103

Commonwealth of Kentucky DEPARTMENT OF HIGHWAYS
KENTON COUNTY
LAYOUT
PREPARED BY Division of Maintenance Bridge Preservation Branch

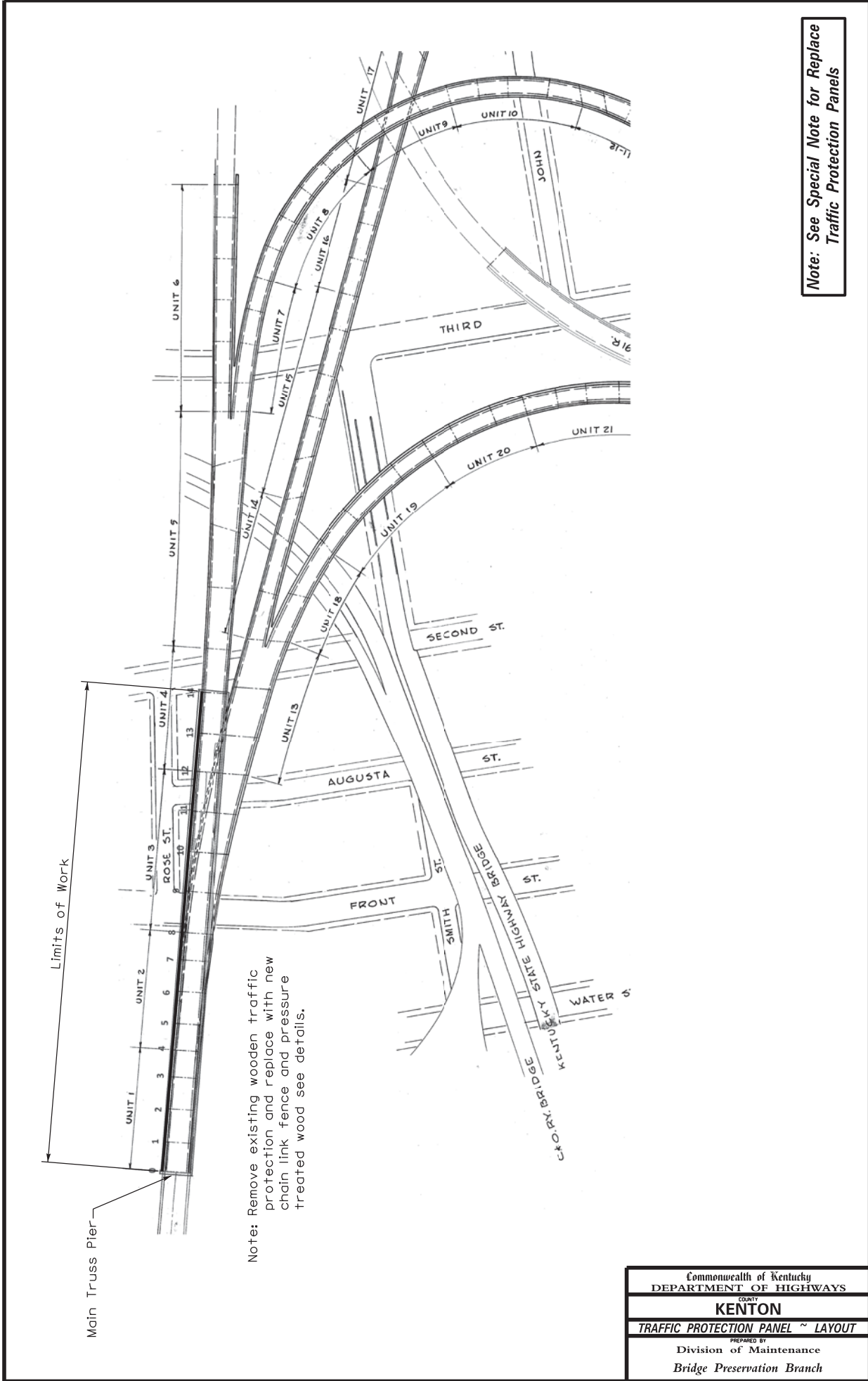

Note: See Special Note for Replace Traffic Protection Panels

Commonwealth of Kentucky DEPARTMENT OF HIGHWAYS
KENTON
TRAFFIC PROTECTION PANEL ~ LAYOUT
PREPARED BY Division of Maintenance Bridge Preservation Branch

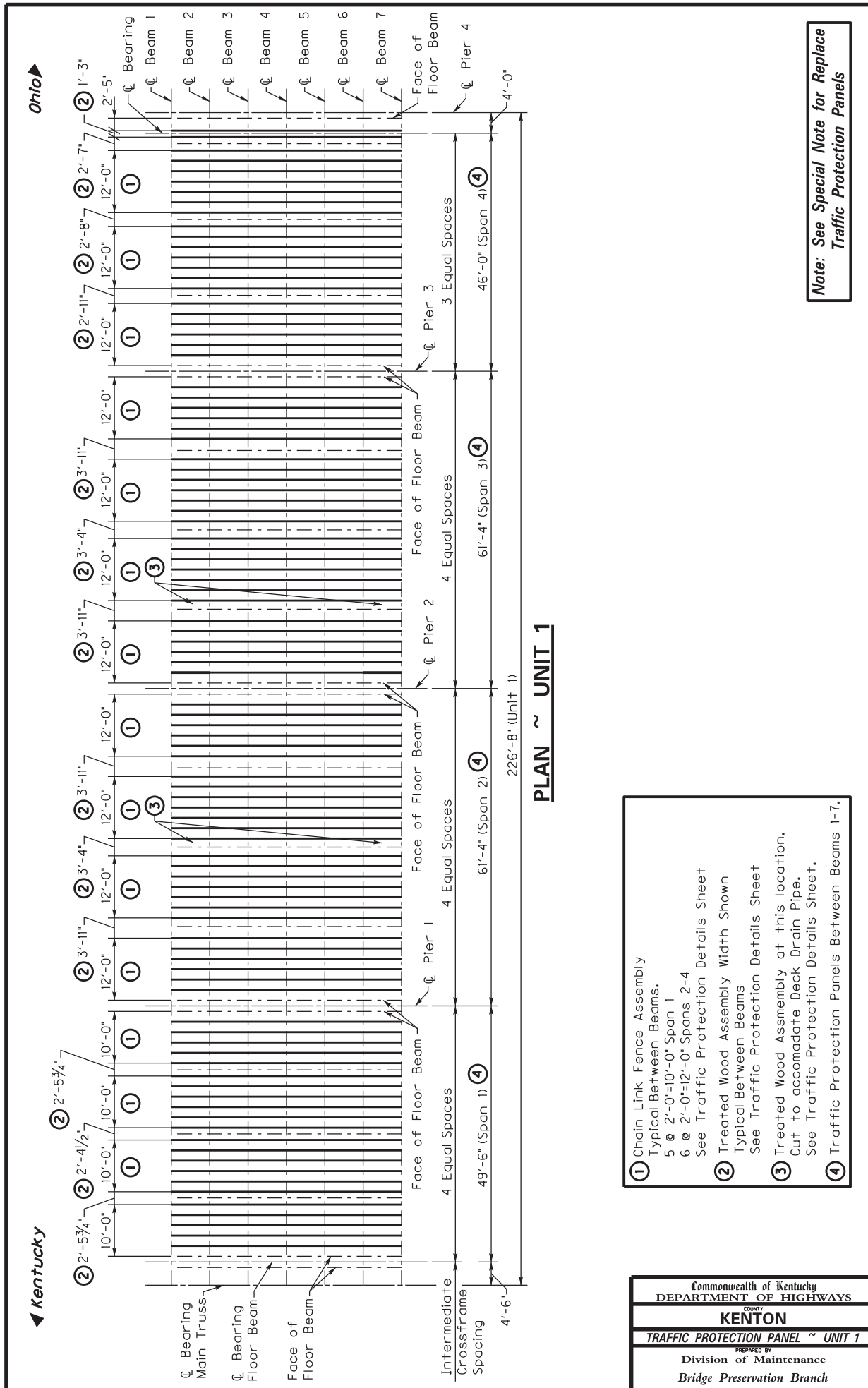

Note: See Special Note for Replace Traffic Protection Panels

PLAN ~ UNIT 1

- ① Chain Link Fence Assembly
Typical Between Beams.
5 @ 2'-0"=10'-0" Span 1
6 @ 2'-0"=12'-0" Spans 2-4
See Traffic Protection Details Sheet
- ② Treated Wood Assembly Width Shown
Typical Between Beams
See Traffic Protection Details Sheet
- ③ Treated Wood Assembly at this location.
Cut to accommodate Deck Drain Pipe.
See Traffic Protection Details Sheet.
- ④ Traffic Protection Panels Between Beams 1-7.

Commonwealth of Kentucky DEPARTMENT OF HIGHWAYS	
COUNTY KENTON	
TRAFFIC PROTECTION PANEL ~ UNIT 1	
PREPARED BY Division of Maintenance Bridge Preservation Branch	

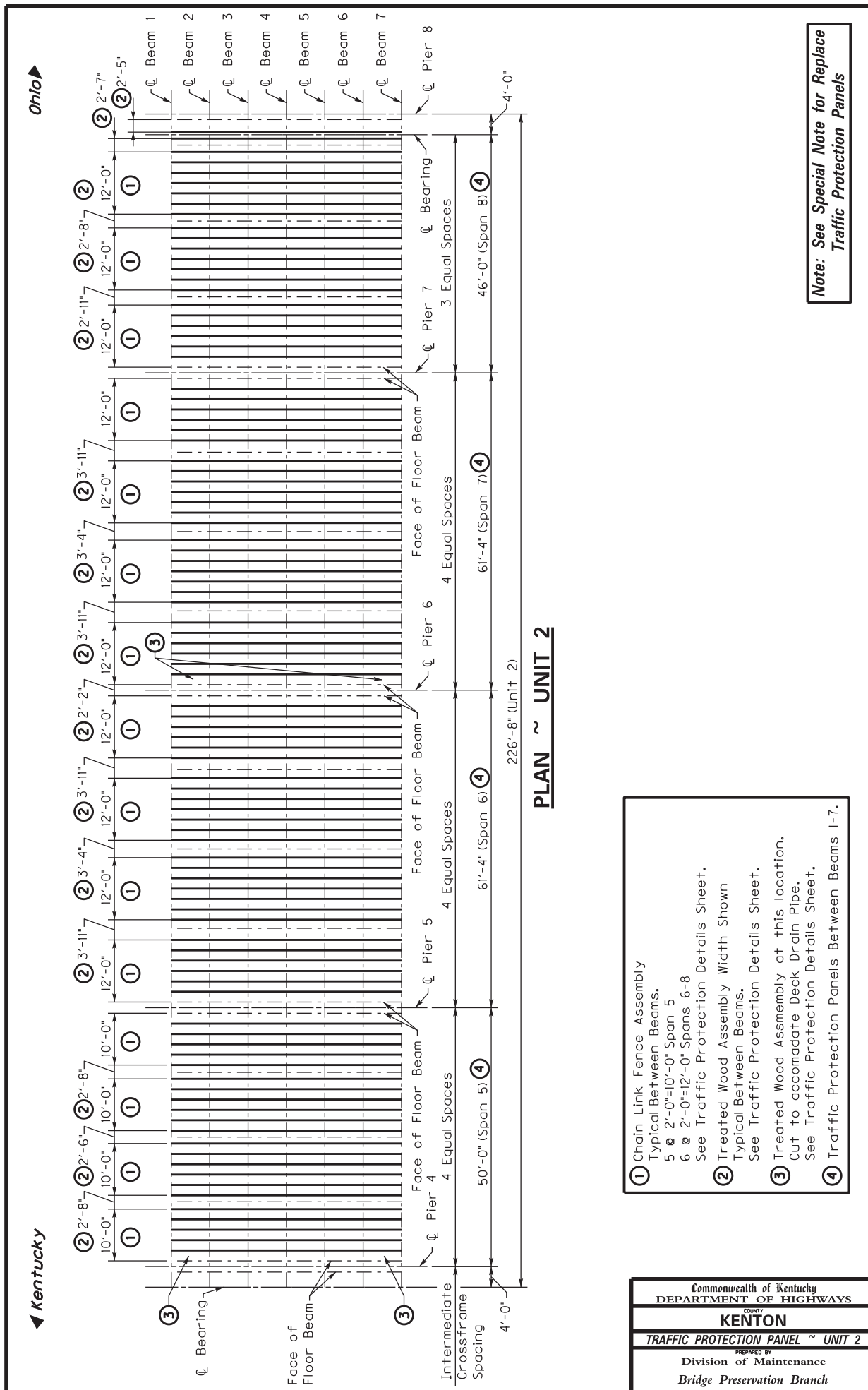

Note: See Special Note for Replace Traffic Protection Panels

- ① Chain Link Fence Assembly
Typical Between Beams.
5 @ 2'-0"=10'-0" Span 5
6 @ 2'-0"=12'-0" Spans 6-8
See Traffic Protection Details Sheet.
- ② Treated Wood Assembly Width Shown
Typical Between Beams.
See Traffic Protection Details Sheet.
- ③ Treated Wood Assembly at this location.
Cut to accommodate Deck Drain Pipe.
See Traffic Protection Details Sheet.
- ④ Traffic Protection Panels Between Beams 1-7.

Commonwealth of Kentucky DEPARTMENT OF HIGHWAYS
COUNTY KENTON
TRAFFIC PROTECTION PANEL ~ UNIT 2
PREPARED BY Division of Maintenance Bridge Preservation Branch

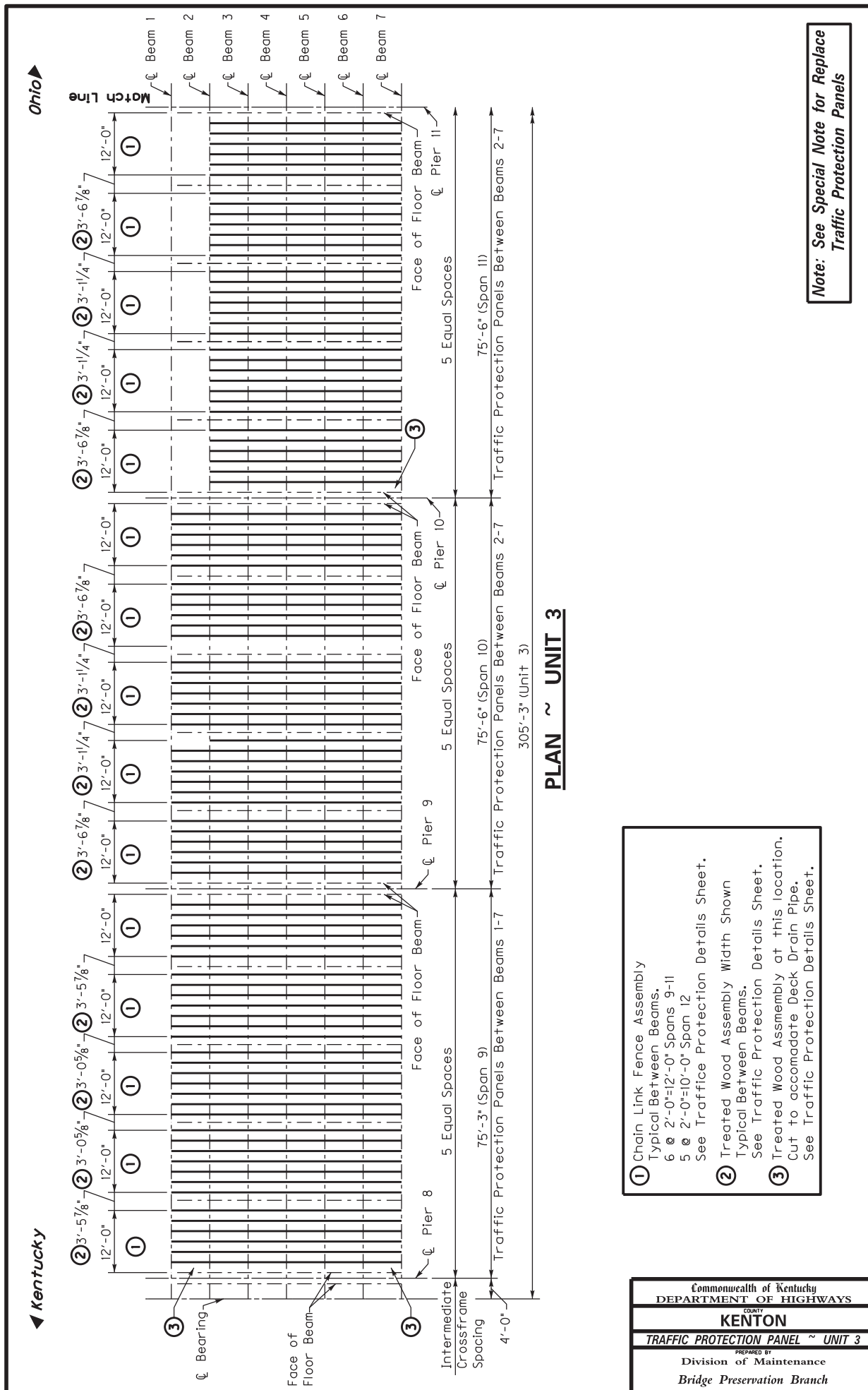

- ① Chain Link Fence Assembly
Typical Between Beams.
6 @ 2'-0"=12'-0" Spans 9-11
5 @ 2'-0"=10'-0" Span 12
See Traffic Protection Details Sheet.
- ② Treated Wood Assembly Width Shown
Typical Between Beams.
See Traffic Protection Details Sheet.
- ③ Treated Wood Assembly at this location.
Cut to accommodate Deck Drain Pipe.
See Traffic Protection Details Sheet.

Commonwealth of Kentucky DEPARTMENT OF HIGHWAYS
KENTON
TRAFFIC PROTECTION PANEL ~ UNIT 3
PREPARED BY Division of Maintenance Bridge Preservation Branch

Ohio

Kentucky

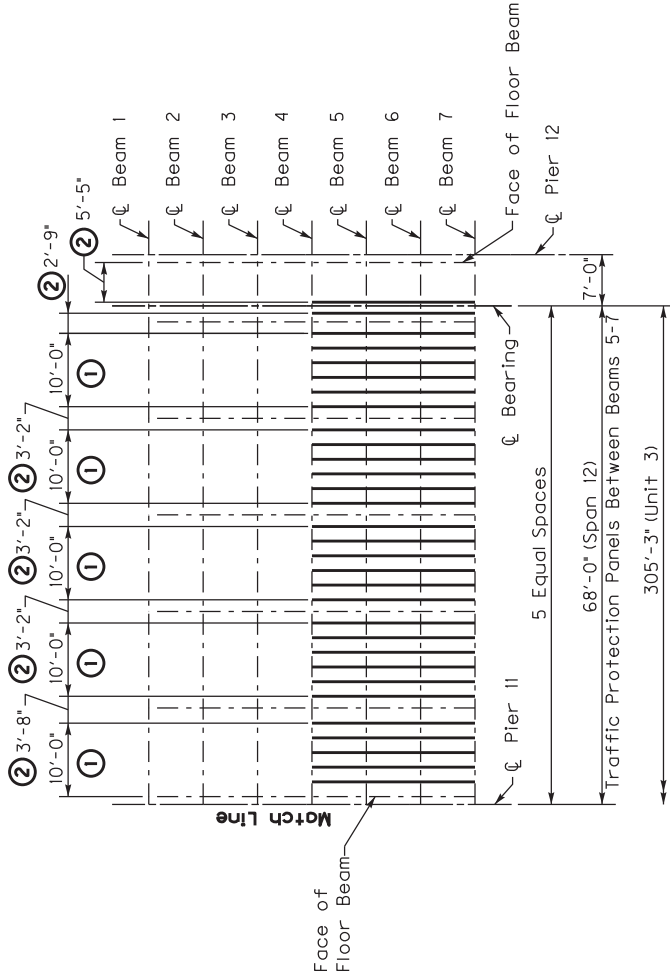

PLAN ~ UNIT 3

- ① Chain Link Fence Assembly
Typical Between Beams.
6 @ 2'-0"=12'-0" Spans 9-11
5 @ 2'-0"=10'-0" Span 12
See Traffic Protection Details Sheet.
- ② Treated Wood Assembly Width Shown
Typical Between Beams.
See Traffic Protection Details Sheet.

Note: See Special Note for Replace Traffic Protection Panels

Commonwealth of Kentucky DEPARTMENT OF HIGHWAYS
COUNTY KENTON
TRAFFIC PROTECTION PANEL ~ UNIT 3
PREPARED BY Division of Maintenance Bridge Preservation Branch

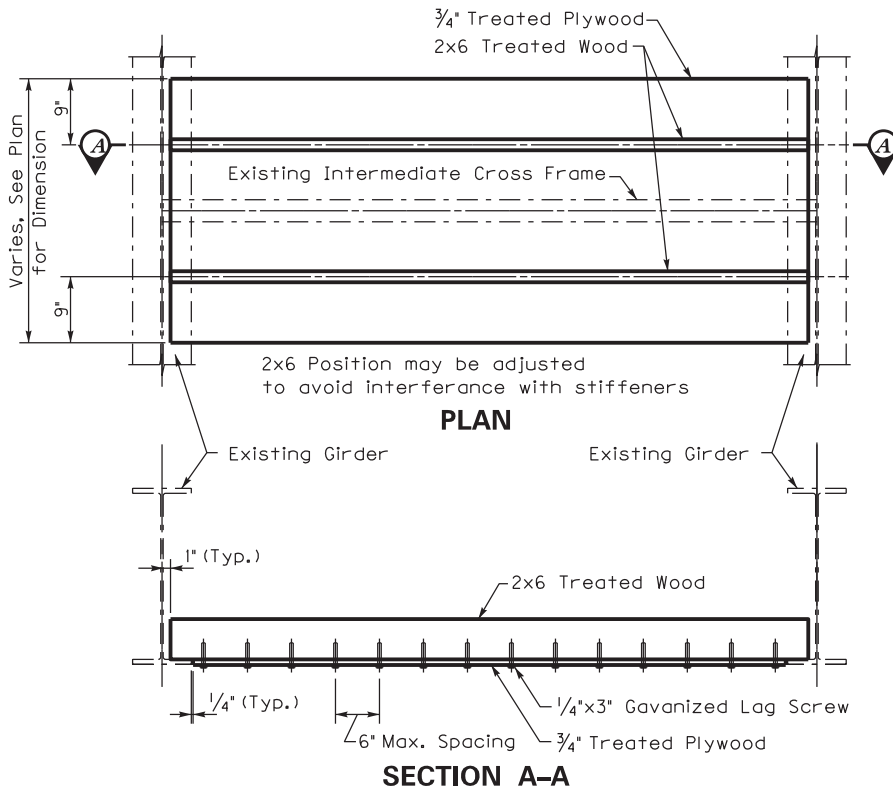

SECTION A-A
PLYWOOD TRAFFIC PROTECTION PANEL

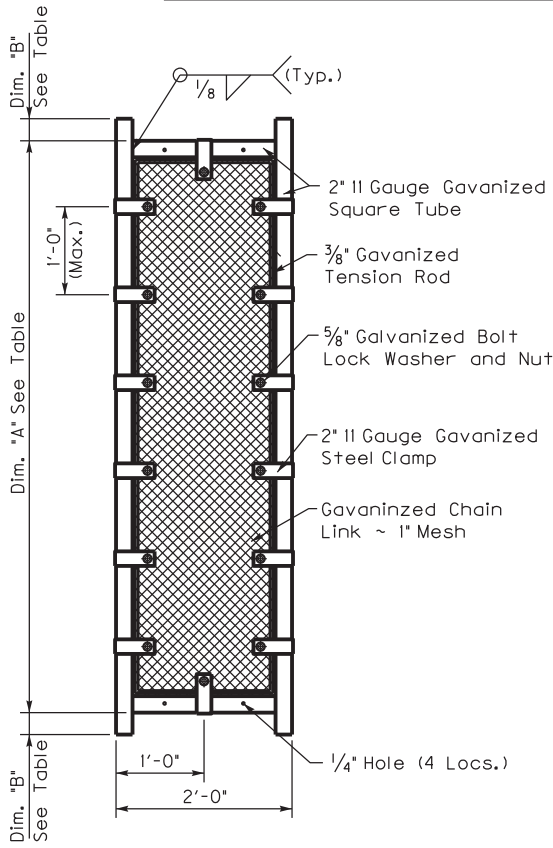

CHAIN LINK MESH PANEL

PANEL SIZE TABLE			
Location	Dim. "A"	Dim. "B"	Total Length
Spans 1-8	6'-6"	3"	7'-0"
Spans 9-12	6'-3 1/2"	4 1/2"	7'-0 1/2"
Spans 13 South Half	6'-3 1/2"	4 1/2"	7'-0 1/2"
Spans 13 North Half	6'-4 1/2"	4 1/2"	7'-1 1/2"
Spans 14 South Half	6'-5 1/2"	4 1/2"	7'-2 1/2"
Spans 14 North Half	6'-6 1/2"	4 1/2"	7'-3 1/2"

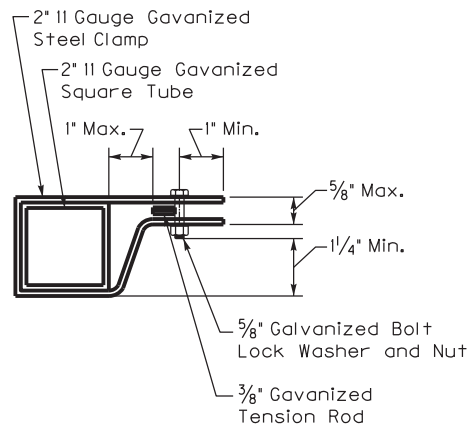

2" CLAMP DETAIL

CHAIN LINK TRAFFIC PROTECTION PANEL

Note: See Special Note for Replace Traffic Protection Panels

Commonwealth of Kentucky DEPARTMENT OF HIGHWAYS
KENTON
REPLACE TRAFFIC PROTECTION DETAILS
PREPARED BY Division of Maintenance Bridge Preservation Branch

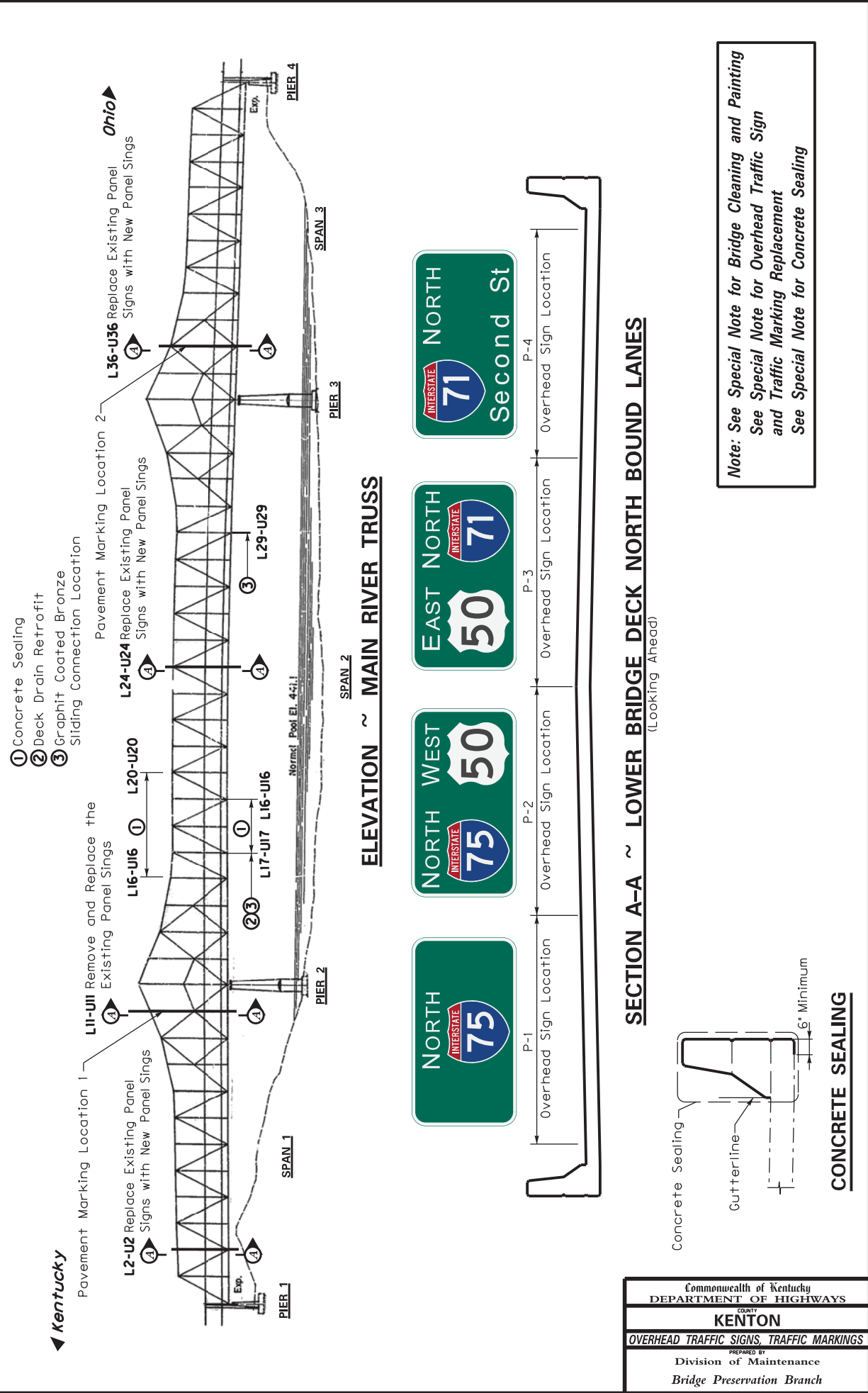

Note: See Special Note for Bridge Cleaning and Painting
See Special Note for Overhead Traffic Sign and Traffic Marking Replacement
See Special Note for Concrete Sealing

Commonwealth of Kentucky DEPARTMENT OF HIGHWAYS	
COUNTY KENTON	
OVERHEAD TRAFFIC SIGNS, TRAFFIC MARKINGS	
PREPARED BY Division of Maintenance Bridge Preservation Branch	

SIGN INFORMATION	
SIGN NUMBER	P-1
QUANTITY	4
WIDTH	9'-0"
HEIGHT	5'-0"
AREA (Sq. Ft.)	45 SO FT
BORDER WIDTH	1.75"
BORDER RADIUS	8"
PANEL COLOR	GREEN
LEGEND/BORDER COLOR	WHITE / WHITE
PANEL MATERIAL	REFLECTIVE
LEGEND MATERIAL	REFLECTIVE
SIGN LOCATION / SUPPORT	
ROAD & MILE POINT	J-75/J-71
TRAFFIC DIRECTION	NORTHBOUND
SIDE OF ROAD	OVERHEAD
MOUNTING STYLE	BRIDGE MOUNTED

Panel Style: guide_exp_advance_minor.ssi
M.U. T.C.D.: 2009 Edition
BORDER
R=8"
TH=2"

SIGN ~ P-1

SIGN INFORMATION	
SIGN NUMBER	P-2
QUANTITY	4
WIDTH	9'-0"
HEIGHT	5'-0"
AREA (Sq. Ft.)	45 SO FT
BORDER WIDTH	1.75"
BORDER RADIUS	8"
PANEL COLOR	GREEN
LEGEND/BORDER COLOR	WHITE / WHITE
PANEL MATERIAL	REFLECTIVE
LEGEND MATERIAL	REFLECTIVE
SIGN LOCATION / SUPPORT	
ROAD & MILE POINT	J-75/J-71
TRAFFIC DIRECTION	NORTHBOUND
SIDE OF ROAD	OVERHEAD
MOUNTING STYLE	BRIDGE MOUNTED

Panel Style: guide_exp_advance_minor.ssi
M.U. T.C.D.: 2009 Edition
BORDER
R=8"
TH=2"

SIGN ~ P-2

SIGN INFORMATION	
SIGN NUMBER	P-3
QUANTITY	4
WIDTH	9'-0"
HEIGHT	5'-0"
AREA (Sq. Ft.)	45 SO FT
BORDER WIDTH	1.75"
BORDER RADIUS	8"
PANEL COLOR	GREEN
LEGEND/BORDER COLOR	WHITE / WHITE
PANEL MATERIAL	REFLECTIVE
LEGEND MATERIAL	REFLECTIVE
SIGN LOCATION / SUPPORT	
ROAD & MILE POINT	J-75/J-71
TRAFFIC DIRECTION	NORTHBOUND
SIDE OF ROAD	OVERHEAD
MOUNTING STYLE	BRIDGE MOUNTED

Panel Style: guide_exp_advance_minor.ssi
M.U. T.C.D.: 2009 Edition
BORDER
R=8"
TH=2"

SIGN ~ P-3

SIGN INFORMATION	
SIGN NUMBER	P-4
QUANTITY	4
WIDTH	9'-0"
HEIGHT	5'-0"
AREA (Sq. Ft.)	45 SO FT
BORDER WIDTH	1.75"
BORDER RADIUS	8"
PANEL COLOR	GREEN
LEGEND/BORDER COLOR	WHITE / WHITE
PANEL MATERIAL	REFLECTIVE
LEGEND MATERIAL	REFLECTIVE
SIGN LOCATION / SUPPORT	
ROAD & MILE POINT	J-75/J-71
TRAFFIC DIRECTION	NORTHBOUND
SIDE OF ROAD	OVERHEAD
MOUNTING STYLE	BRIDGE MOUNTED

Panel Style: guide_exp_advance_minor.ssi
M.U. T.C.D.: 2009 Edition
BORDER
R=8"
TH=2"

SIGN ~ P-4

Note: See Special Note for Overhead Traffic Sign and Traffic Marking Replacement

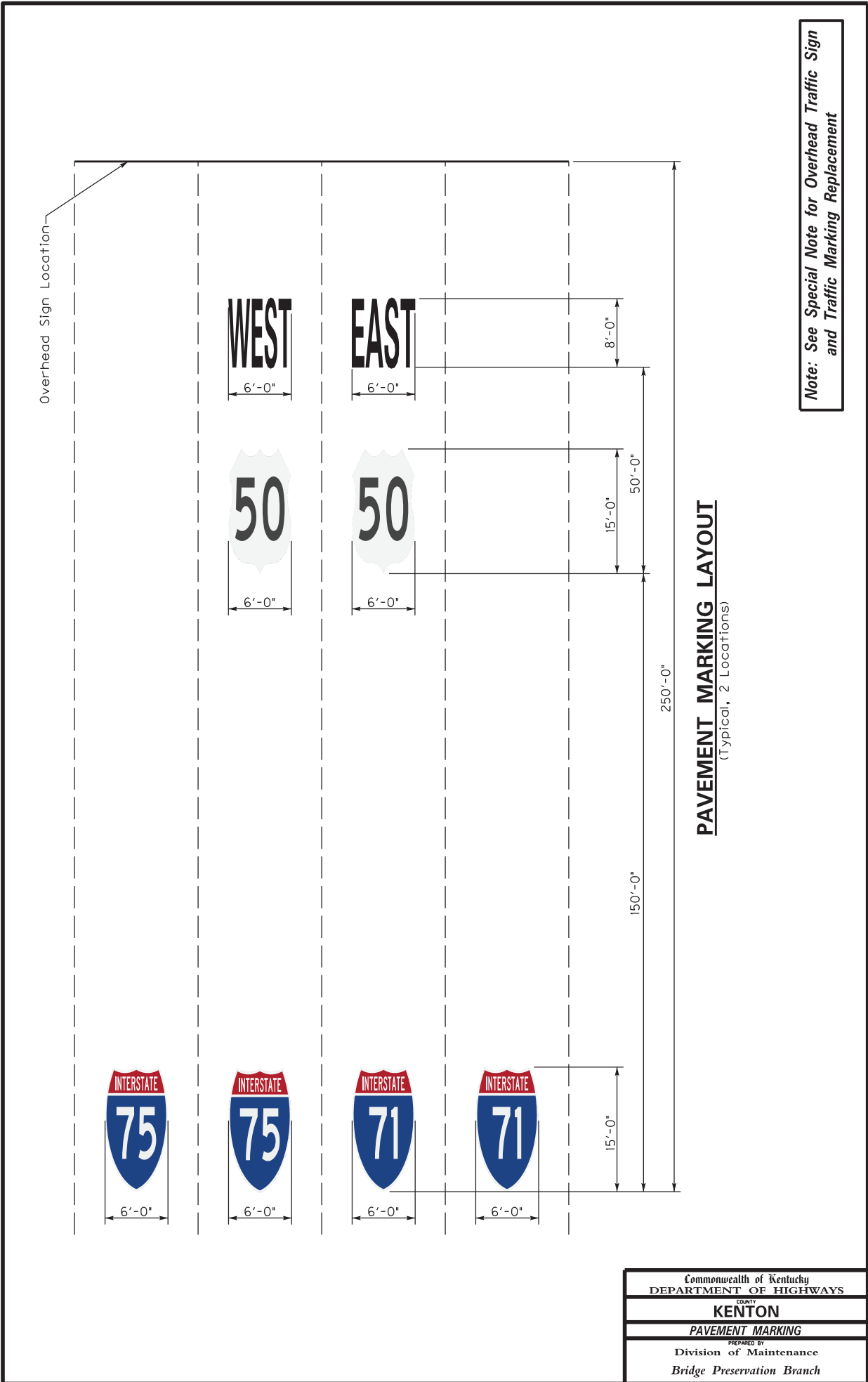

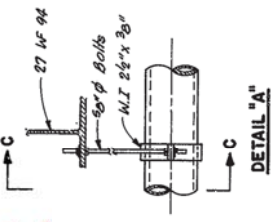
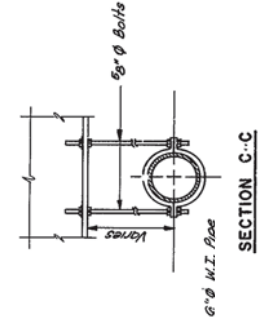
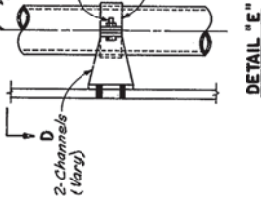
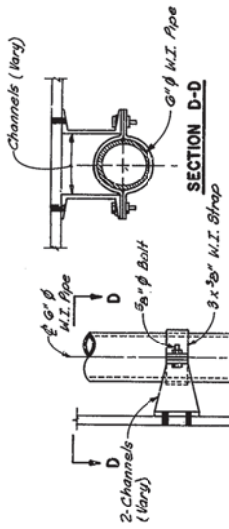
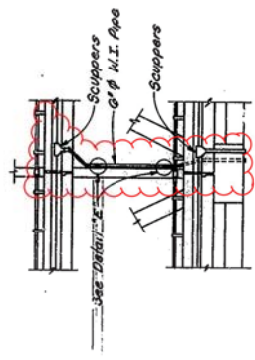
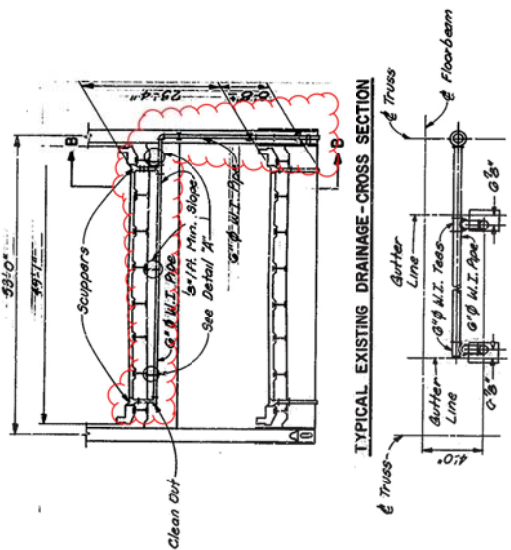

At panel point 17 remove and replace all piping, couplings, and connections in like kind or with another Engineer approved system. Routing of piping shall be the same or similar to that shown in these plans and/or as exists on the bridge. Connect new piping to both scuppers and the joint drainage trough. Piping shall be 6" diameter and the horizontal run shall have a minimum slope of 1.00%.

- Notes:
- 1) Any Drainage Details Shown For The Lower Deck Is For Information Only. For Lower Deck Drain Details, See Sht. 21.
 - 2) The Existing Drainage System At Panel Points 0, 8, 17 & 17' Below The Existing Coupling Located Approximately 1.5' Below Gutter Line Shall Remain In Place.

EXISTING DRAINAGE SYSTEM

Commonwealth of Kentucky DEPARTMENT OF HIGHWAYS
KENTON
DECK DRAIN RETROFIT
PREPARED BY Division of Maintenance Bridge Preservation Branch

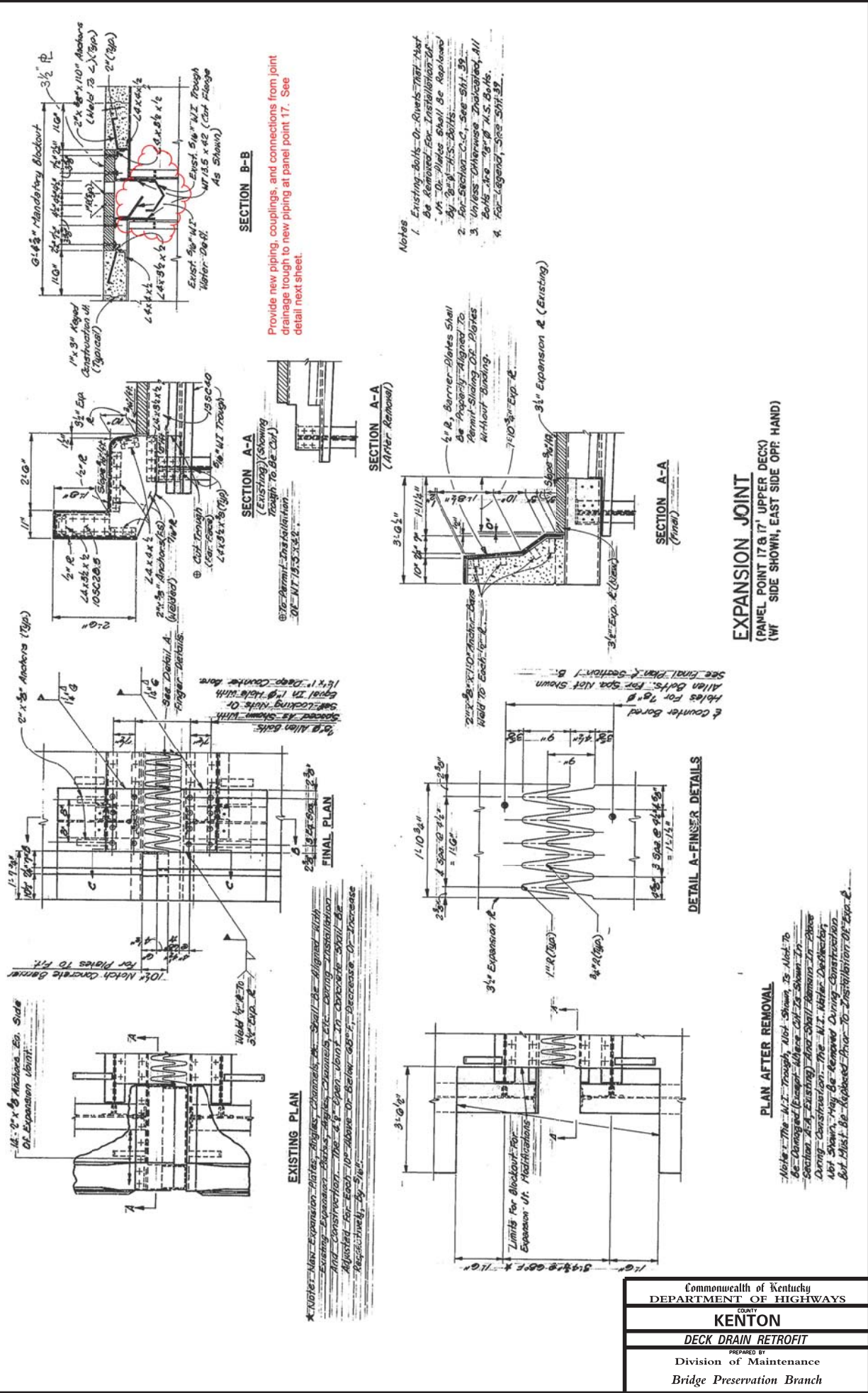

SECTION B-B
Provide new piping, couplings, and connections from joint drainage trough to new piping at panel point 17. See detail next sheet.

- Notes
- Existing bolts or rivets that must be removed for installation of new plates shall be replaced by 3/4" A.S. bolts.
 - For Section C-C, see Sht. 39.
 - Unless otherwise indicated, all bolts are 1/2" A.S. bolts.
 - For legend, see Sht. 39.

EXPANSION JOINT
(PANEL POINT 17 & 17' UPPER DECK)
(WF SIDE SHOWN, EAST SIDE OFF HAND)

DETAIL A-FINGER DETAILS

PLAN AFTER REMOVAL

Note: The N.T. Trough, N.T. Shows, Is Not To Be Damaged Except Where Shown In Section A-A, Existing) And Shall Remain In Place During Construction. The N.T. Niche, Decking Not Shown, May Be Removed During Construction But Must Be Replaced Prior To Installation Of Exp. J.

EXISTING PLAN
*Notes: New Expansion Plates, Angles, Channels, Etc. Shall Be Aligned With Existing Expansion Bars, Angles, Channels Etc. During Installation And Construction. The 2" Upper Unit In Concrete Shall Be Adjusted For Each 1" Above Or Below 65°F. Decrease Or Increase Respectively, By 5/8".

Commonwealth of Kentucky
DEPARTMENT OF HIGHWAYS
COUNTY
KENTON
DECK DRAIN RETROFIT
PREPARED BY
Division of Maintenance
Bridge Preservation Branch

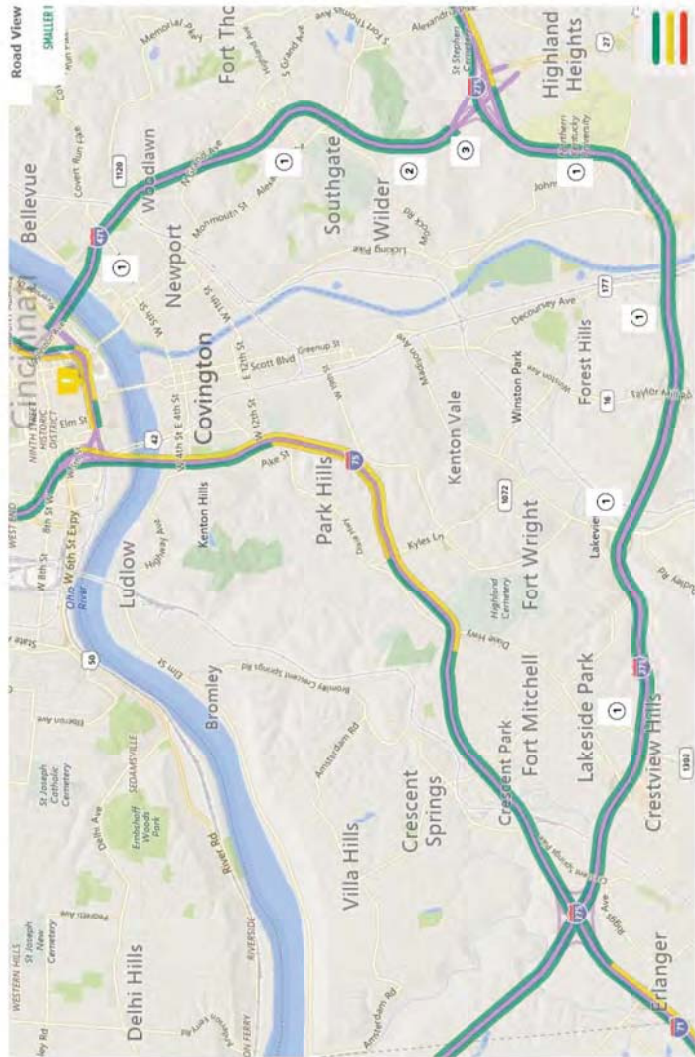

Detour trailblazing signs to be placed along southbound I-471 and westbound I-275.





May be mounted to the side of existing route shield sign supports (OMUTCD Figure 6H-9).

Signs 2 and 3 should be placed adjacent overhead sign supports directing traffic to west 275.

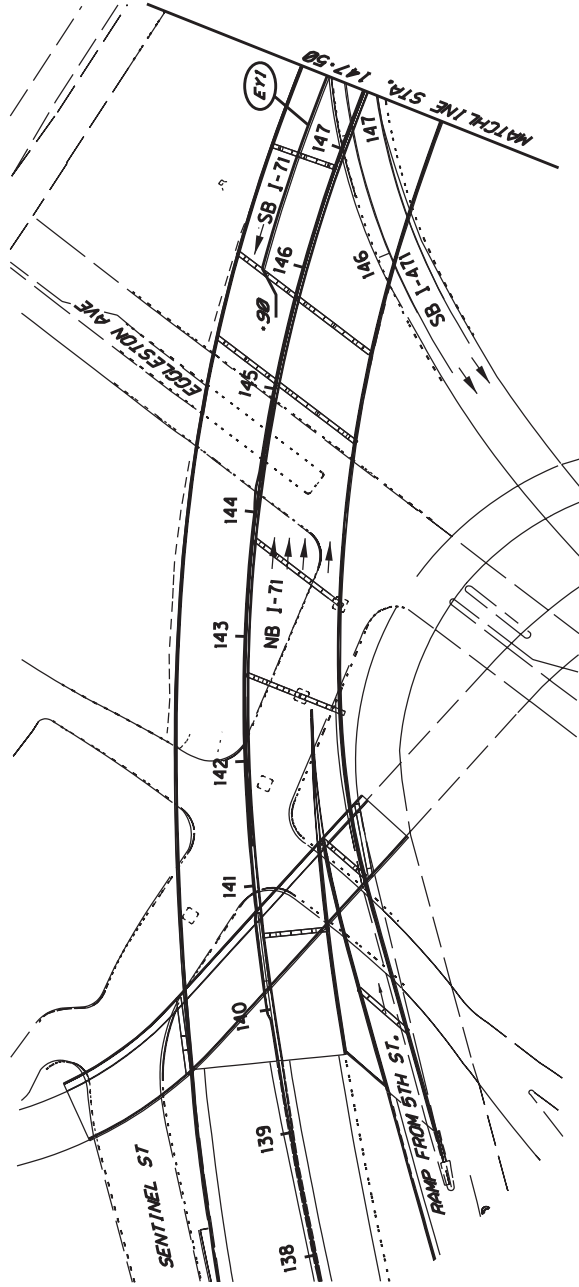

Commonwealth of Kentucky DEPARTMENT OF HIGHWAYS
KENTON
I-71 DETOUR PLAN
PREPARED BY Division of Maintenance Bridge Preservation Branch



-  Work Zone Channelizing Line
-  Work Zone Dotted Line
-  Work Edge Zone Line, Yellow
-  Work Edge Zone Line, White
-  Work Zone Lane Line

PLAN ~ STA. 138+00 TO STA. 147.00

Commonwealth of Kentucky DEPARTMENT OF HIGHWAYS
COUNTY KENTON
I-71 DETOUR PLAN
PREPARED BY Division of Maintenance Bridge Preservation Branch

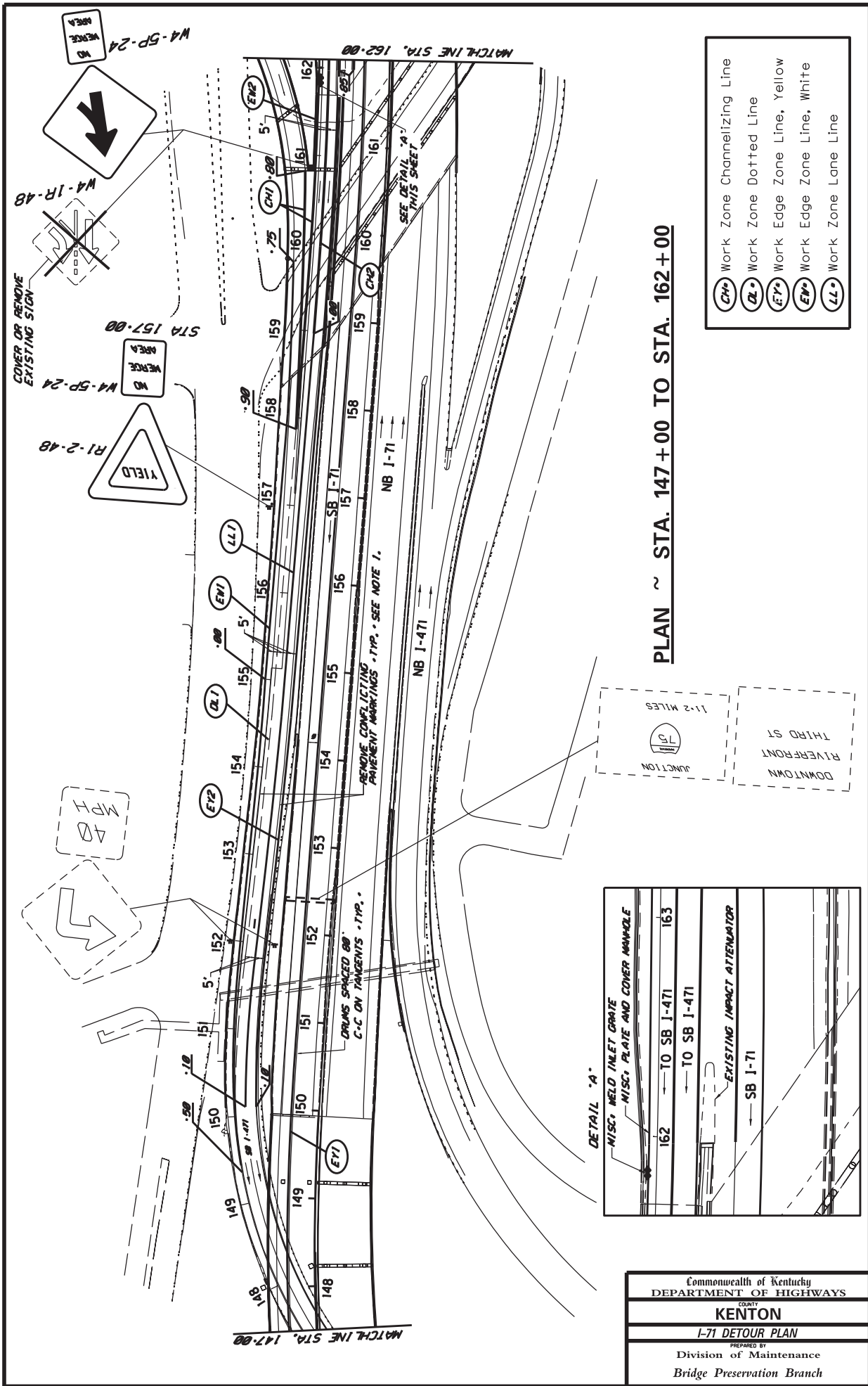

Commonwealth of Kentucky DEPARTMENT OF HIGHWAYS	
COUNTY KENTON	
I-71 DETOUR PLAN	
PREPARED BY Division of Maintenance Bridge Preservation Branch	

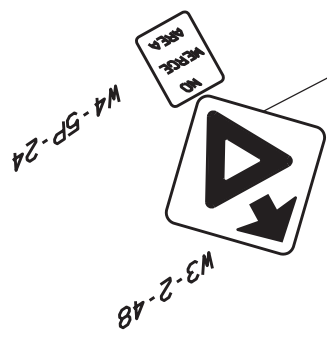
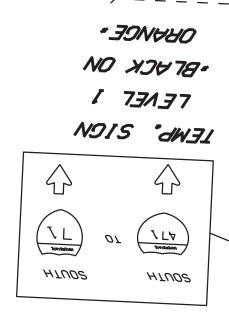
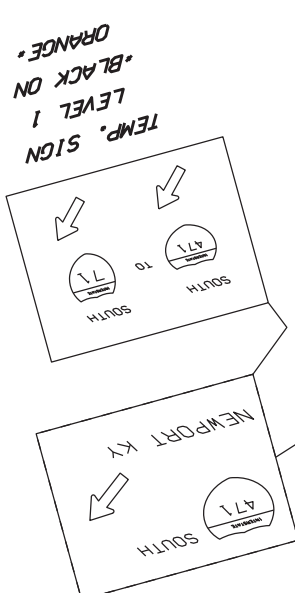
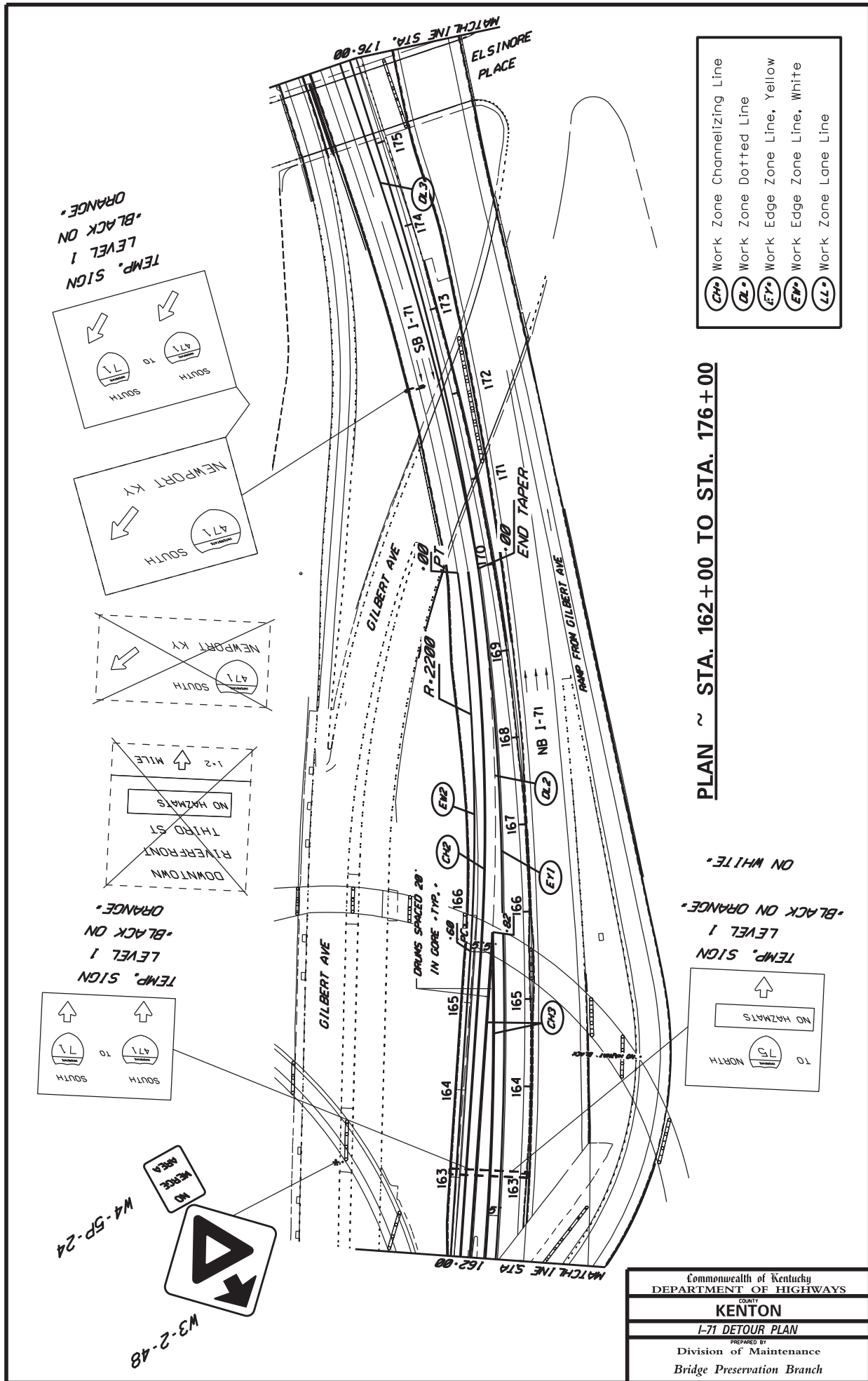

- Work Zone Channelizing Line
- Work Zone Dotted Line
- Work Edge Zone Line, Yellow
- Work Edge Zone Line, White
- Work Zone Lane Line

PLAN ~ STA. 162+00 TO STA. 176+00

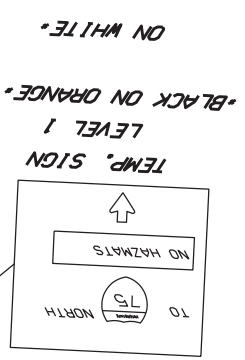

Commonwealth of Kentucky
DEPARTMENT OF HIGHWAYS

KENTON

I-71 DETOUR PLAN

PREPARED BY
Division of Maintenance
Bridge Preservation Branch

- Work Zone Channelizing Line
- Work Zone Dotted Line
- Work Edge Zone Line, Yellow
- Work Edge Zone Line, White
- Work Zone Lane Line

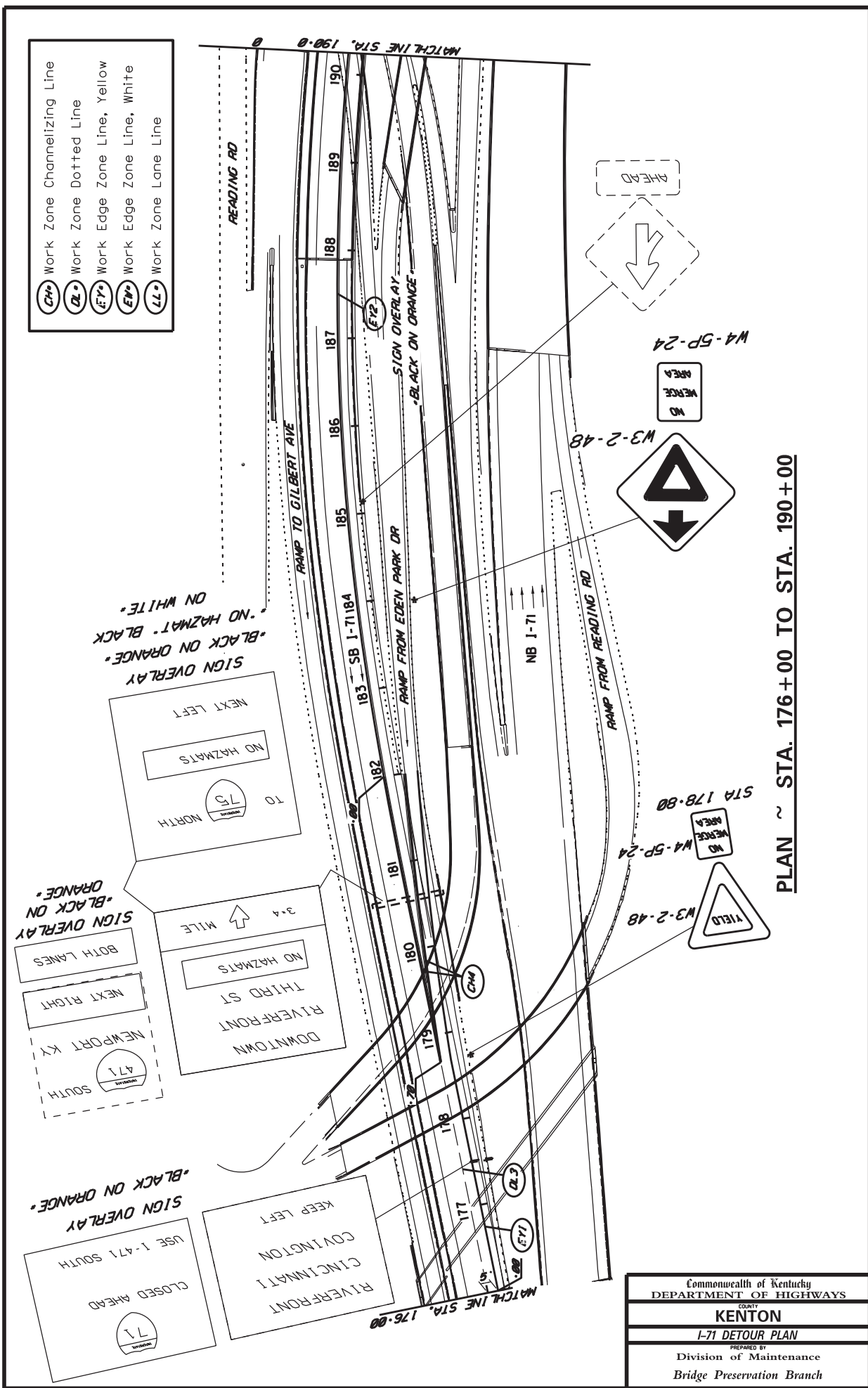

ON WHITE
BLACK ON ORANGE
BLACK ON ORANGE
SIGN OVERLAY

TO NORTH
NO HAZMAT
NEXT LEFT
SIGN OVERLAY
BLACK ON ORANGE
BOTH LANES
NEXT RIGHT
NEWPORT KY
SOUTH

KEEP LEFT
CINCINNATI
COVINGTON
USE I-471 SOUTH
CLOSED AHEAD
SIGN OVERLAY
BLACK ON ORANGE

PLAN ~ STA. 176+00 TO STA. 190+00

Commonwealth of Kentucky DEPARTMENT OF HIGHWAYS
KENTON
I-71 DETOUR PLAN
PREPARED BY Division of Maintenance Bridge Preservation Branch

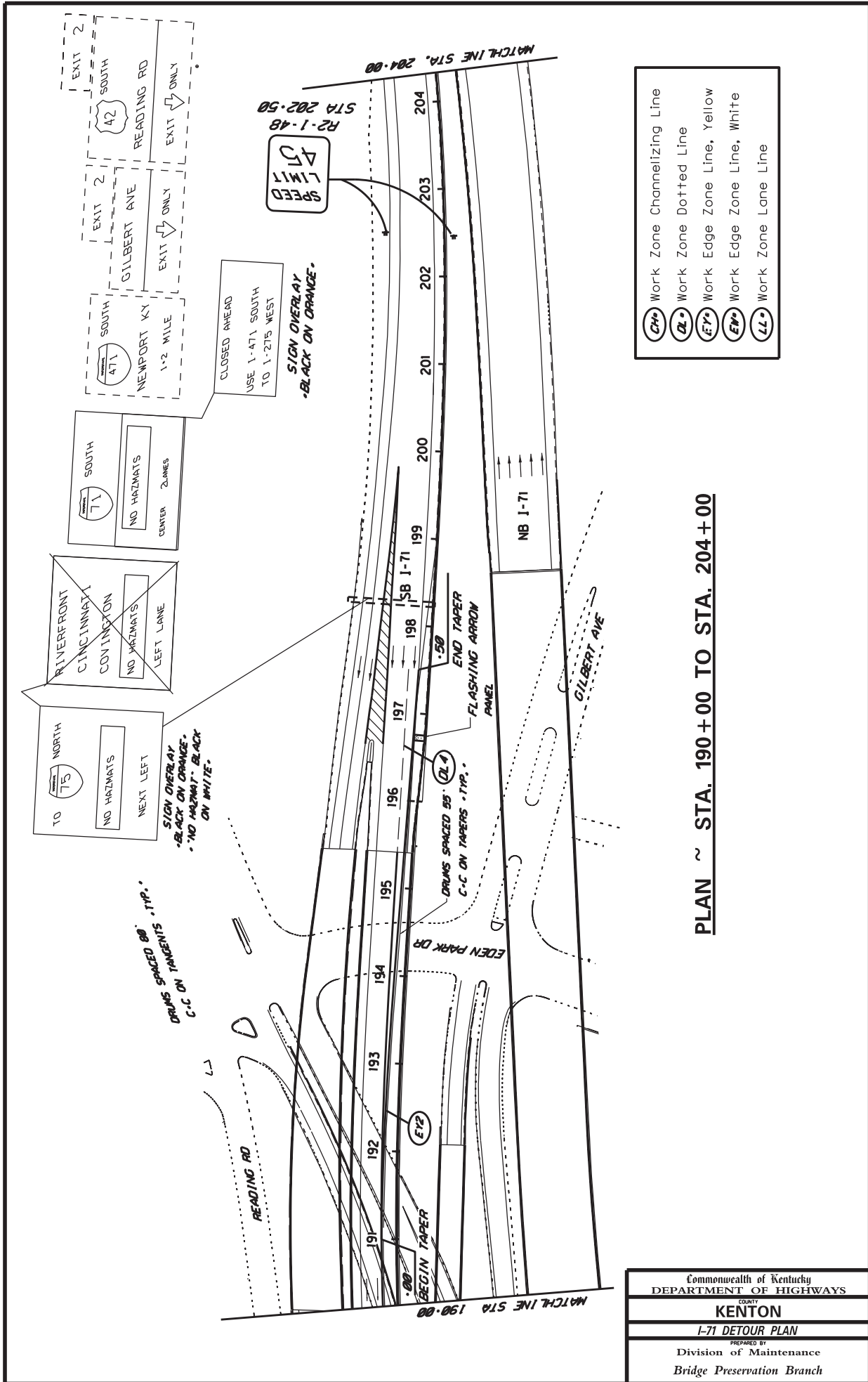

PLAN ~ STA. 190+00 TO STA. 204+00

Commonwealth of Kentucky DEPARTMENT OF HIGHWAYS
KENTON
I-71 DETOUR PLAN
PREPARED BY Division of Maintenance Bridge Preservation Branch

- Work Zone Channelizing Line
- Work Zone Dotted Line
- Work Edge Zone Line, Yellow
- Work Edge Zone Line, White
- Work Zone Lane Line

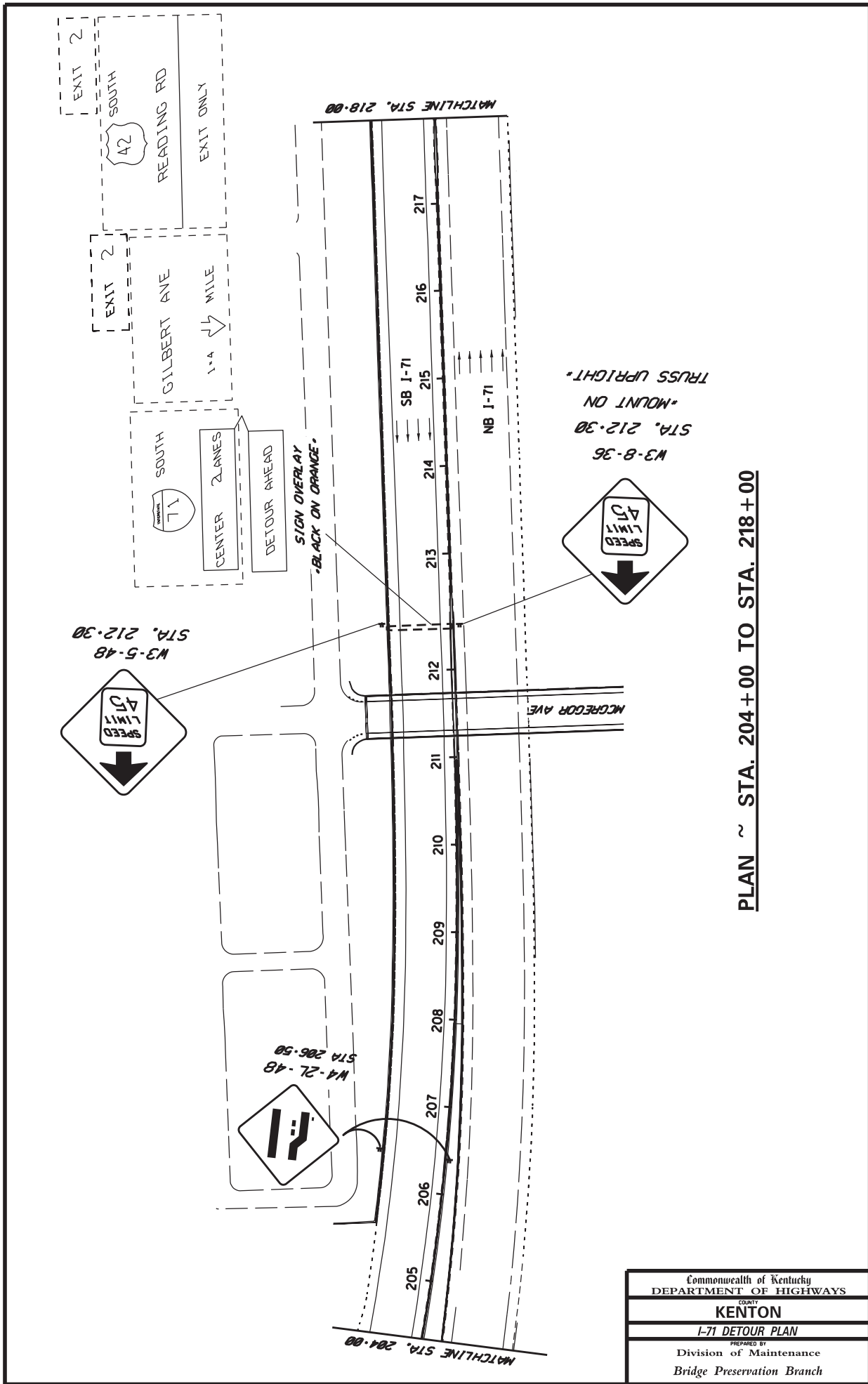

PLAN ~ STA. 204+00 TO STA. 218+00

Commonwealth of Kentucky DEPARTMENT OF HIGHWAYS
KENTON
I-71 DETOUR PLAN
PREPARED BY Division of Maintenance Bridge Preservation Branch

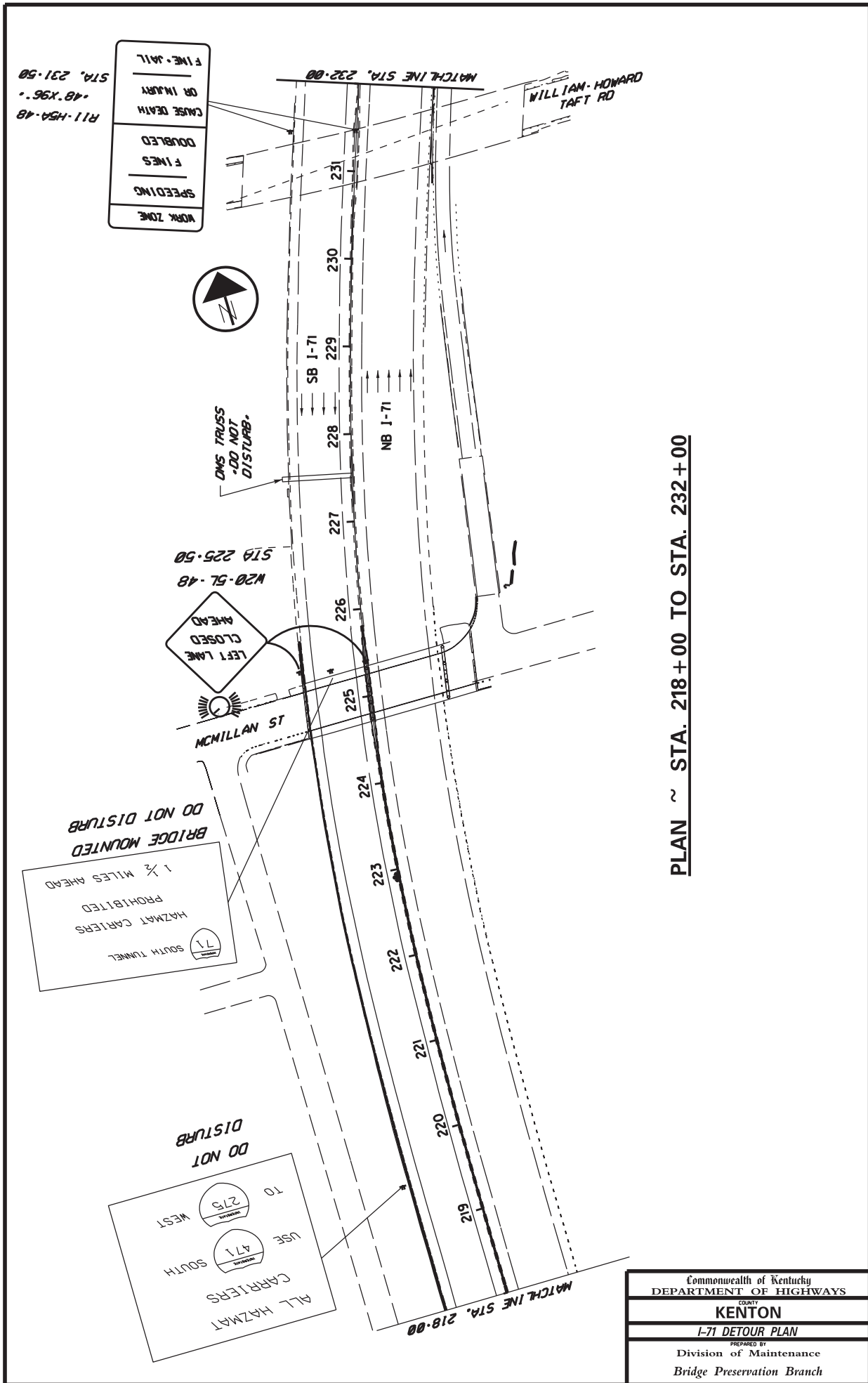

PLAN ~ STA. 218+00 TO STA. 232+00

Commonwealth of Kentucky DEPARTMENT OF HIGHWAYS
KENTON
I-71 DETOUR PLAN
PREPARED BY Division of Maintenance Bridge Preservation Branch

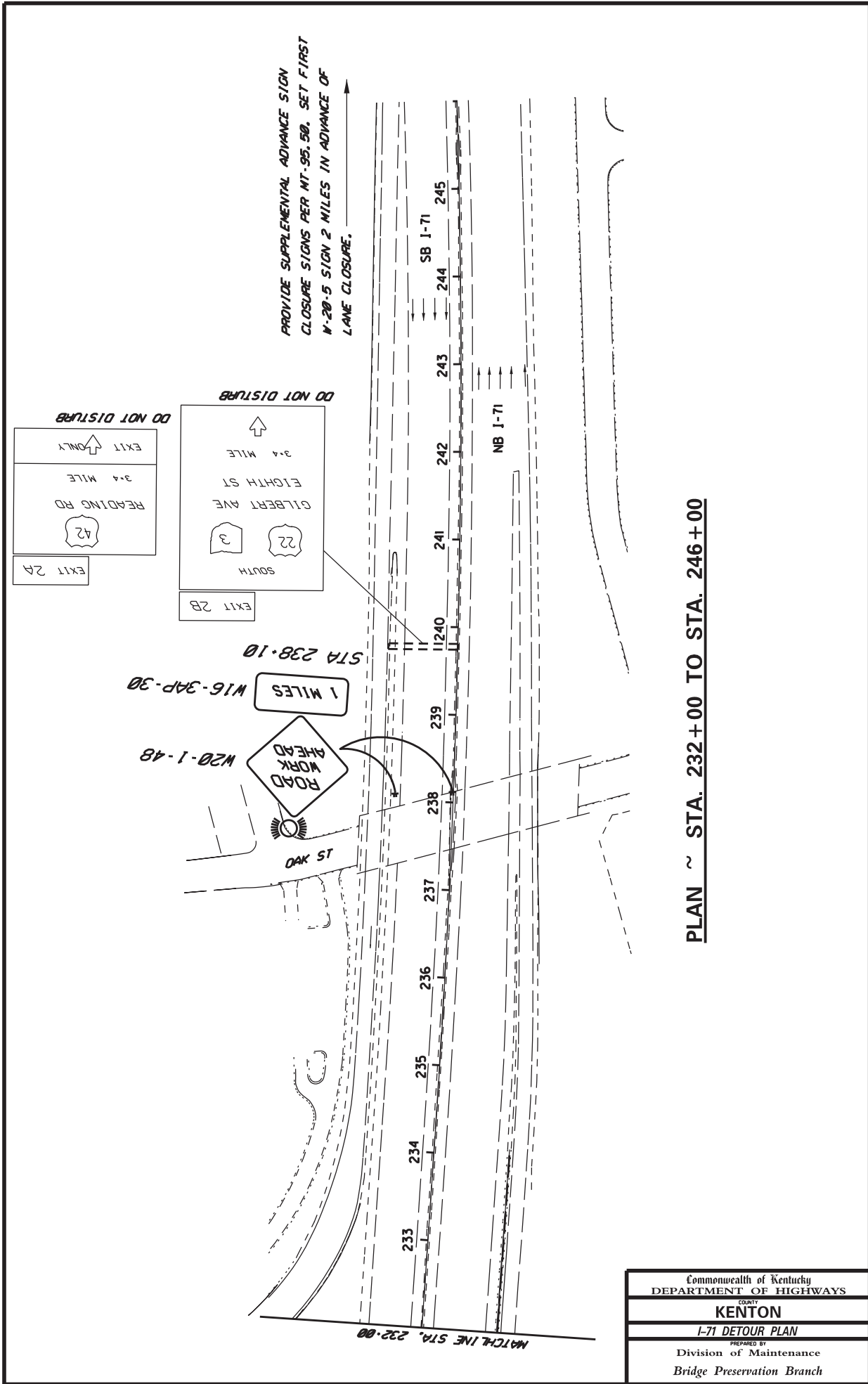

PLAN ~ STA. 232+00 TO STA. 246+00

Commonwealth of Kentucky DEPARTMENT OF HIGHWAYS
KENTON
I-71 DETOUR PLAN
PREPARED BY Division of Maintenance Bridge Preservation Branch

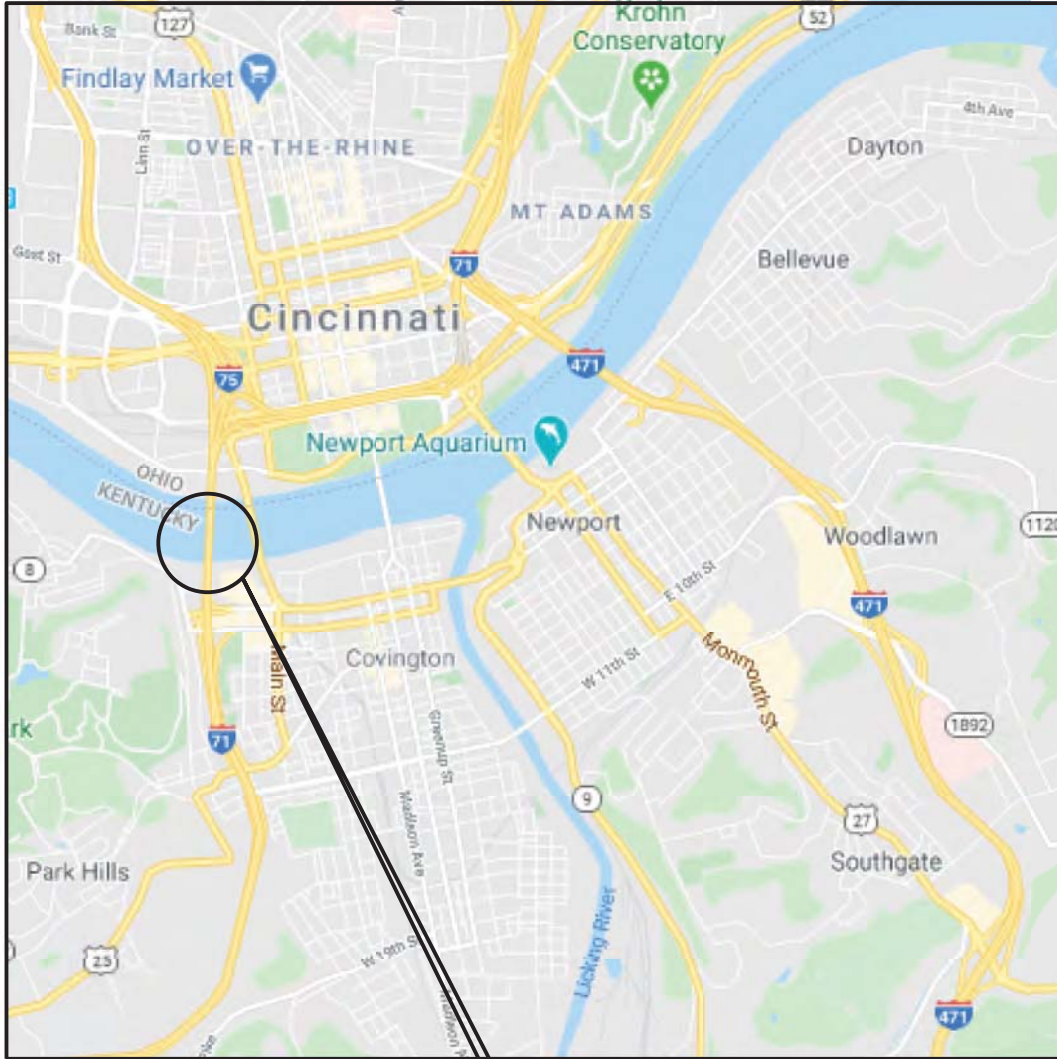

ITEM NO. 6-17.09 - NHPP IM 0758(107)
I-71 / I-75 over Ohio River

LOCATION MAP

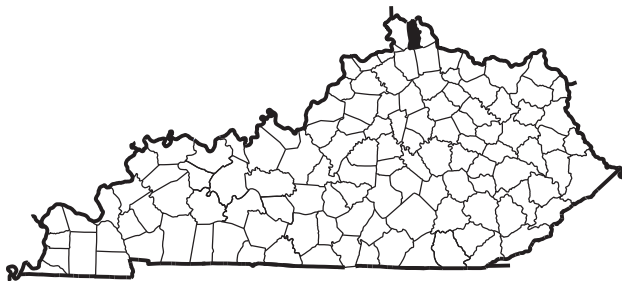

Commonwealth of Kentucky DEPARTMENT OF HIGHWAYS
COUNTY KENTON
LOCATION MAP
PREPARED BY Division of Maintenance Bridge Preservation Branch

**SPECIAL NOTE FOR PRE-BID CONFERENCE
DISTRICT NO. 6 - KENTON COUNTY
BRIDGE CLEANING AND PAINTING
ITEM NO. 6-17.09 - NHPP IM 0758(107)
059GR21M007 - CID 212955**

The Department will conduct a Mandatory Pre-Bid Conference of the subject project at the dates and times below:

Pre-Bid Conference

(by Video Conference)

Date: Friday January 15, 2021

Time: 1:00 p.m.

Any company that is interested in bidding on the subject project or being part of a joint venture shall be represented at the video conference. No individual can represent more than one company. At the video conference of the subject bridge, a roster shall be taken of the representatives present. In addition, following the video conference each company shall submit a signed affidavit listing the company members attending the video conference. The video conference will also be recorded in order to verify attendance. **Only companies represented on the video conference, have submitted the affidavit by the due date will be eligible to have their bids opened at the date of letting.**

The purpose of the video conference is to familiarize all prospective bidders with the contract requirements and the location and condition of all structures within the scope of the contract.

Department of Highways officials present at the video conference will answer questions concerning the projects.

Companies interesting in bidding on the subject project should contact **Tom Mathews** at **tom.mathews@ky.gov** before **4:30 p.m. Friday, January 14, 2021** to obtain a link to the video conference and a copy of the affidavit.

This link and affidavit must be requested through the Kentucky Transportation cabinet using this contact ONLY to be eligible to bid.

PART II
SPECIFICATIONS AND STANDARD DRAWINGS

SPECIFICATIONS REFERENCE

Any reference in the plans or proposal to previous editions of the *Standard Specifications for Road and Bridge Construction* and *Standard Drawings* are superseded by *Standard Specifications for Road and Bridge Construction, Edition of 2019* and *Standard Drawings, Edition of 2020*.

SUPPLEMENTAL SPECIFICATIONS

The contractor shall use the Supplemental Specifications that are effective at the time of letting.
The Supplemental Specifications can be found at the following link:

<http://transportation.ky.gov/Construction/Pages/Kentucky-Standard-Specifications.aspx>

PART III

EMPLOYMENT, WAGE AND RECORD REQUIREMENTS

FHWA-1273 -- Revised May 1, 2012

**REQUIRED CONTRACT PROVISIONS
FEDERAL-AID CONSTRUCTION CONTRACTS**

- I. General
- II. Nondiscrimination
- III. Nonsegregated Facilities
- IV. Davis-Bacon and Related Act Provisions
- V. Contract Work Hours and Safety Standards Act Provisions
- VI. Subletting or Assigning the Contract
- VII. Safety: Accident Prevention
- VIII. False Statements Concerning Highway Projects
- IX. Implementation of Clean Air Act and Federal Water Pollution Control Act
- X. Compliance with Governmentwide Suspension and Debarment Requirements
- XI. Certification Regarding Use of Contract Funds for Lobbying

ATTACHMENTS

A. Employment and Materials Preference for Appalachian Development Highway System or Appalachian Local Access Road Contracts (included in Appalachian contracts only)

I. GENERAL

1. Form FHWA-1273 must be physically incorporated in each construction contract funded under Title 23 (excluding emergency contracts solely intended for debris removal). The contractor (or subcontractor) must insert this form in each subcontract and further require its inclusion in all lower tier subcontracts (excluding purchase orders, rental agreements and other agreements for supplies or services).

The applicable requirements of Form FHWA-1273 are incorporated by reference for work done under any purchase order, rental agreement or agreement for other services. The prime contractor shall be responsible for compliance by any subcontractor, lower-tier subcontractor or service provider.

Form FHWA-1273 must be included in all Federal-aid design-build contracts, in all subcontracts and in lower tier subcontracts (excluding subcontracts for design services, purchase orders, rental agreements and other agreements for supplies or services). The design-builder shall be responsible for compliance by any subcontractor, lower-tier subcontractor or service provider.

Contracting agencies may reference Form FHWA-1273 in bid proposal or request for proposal documents, however, the Form FHWA-1273 must be physically incorporated (not referenced) in all contracts, subcontracts and lower-tier subcontracts (excluding purchase orders, rental agreements and other agreements for supplies or services related to a construction contract).

2. Subject to the applicability criteria noted in the following sections, these contract provisions shall apply to all work performed on the contract by the contractor's own organization and with the assistance of workers under the contractor's immediate superintendence and to all work performed on the contract by piecework, station work, or by subcontract.

3. A breach of any of the stipulations contained in these Required Contract Provisions may be sufficient grounds for withholding of progress payments, withholding of final payment, termination of the contract, suspension / debarment or any other action determined to be appropriate by the contracting agency and FHWA.

4. Selection of Labor: During the performance of this contract, the contractor shall not use convict labor for any purpose within the limits of a construction project on a Federal-aid highway unless it is labor performed by convicts who are on parole, supervised release, or probation. The term Federal-aid highway does not include roadways functionally classified as local roads or rural minor collectors.

II. NONDISCRIMINATION

The provisions of this section related to 23 CFR Part 230 are applicable to all Federal-aid construction contracts and to all related construction subcontracts of \$10,000 or more. The provisions of 23 CFR Part 230 are not applicable to material supply, engineering, or architectural service contracts.

In addition, the contractor and all subcontractors must comply with the following policies: Executive Order 11246, 41 CFR 60, 29 CFR 1625-1627, Title 23 USC Section 140, the Rehabilitation Act of 1973, as amended (29 USC 794), Title VI of the Civil Rights Act of 1964, as amended, and related regulations including 49 CFR Parts 21, 26 and 27; and 23 CFR Parts 200, 230, and 633.

The contractor and all subcontractors must comply with: the requirements of the Equal Opportunity Clause in 41 CFR 60-1.4(b) and, for all construction contracts exceeding \$10,000, the Standard Federal Equal Employment Opportunity Construction Contract Specifications in 41 CFR 60-4.3.

Note: The U.S. Department of Labor has exclusive authority to determine compliance with Executive Order 11246 and the policies of the Secretary of Labor including 41 CFR 60, and 29 CFR 1625-1627. The contracting agency and the FHWA have the authority and the responsibility to ensure compliance with Title 23 USC Section 140, the Rehabilitation Act of 1973, as amended (29 USC 794), and Title VI of the Civil Rights Act of 1964, as amended, and related regulations including 49 CFR Parts 21, 26 and 27; and 23 CFR Parts 200, 230, and 633.

The following provision is adopted from 23 CFR 230, Appendix A, with appropriate revisions to conform to the U.S. Department of Labor (US DOL) and FHWA requirements.

1. Equal Employment Opportunity: Equal employment opportunity (EEO) requirements not to discriminate and to take affirmative action to assure equal opportunity as set forth under laws, executive orders, rules, regulations (28 CFR 35, 29 CFR 1630, 29 CFR 1625-1627, 41 CFR 60 and 49 CFR 27) and orders of the Secretary of Labor as modified by the provisions prescribed herein, and imposed pursuant to 23 U.S.C. 140 shall constitute the EEO and specific affirmative action standards for the contractor's project activities under

this contract. The provisions of the Americans with Disabilities Act of 1990 (42 U.S.C. 12101 et seq.) set forth under 28 CFR 35 and 29 CFR 1630 are incorporated by reference in this contract. In the execution of this contract, the contractor agrees to comply with the following minimum specific requirement activities of EEO:

a. The contractor will work with the contracting agency and the Federal Government to ensure that it has made every good faith effort to provide equal opportunity with respect to all of its terms and conditions of employment and in their review of activities under the contract.

b. The contractor will accept as its operating policy the following statement:

"It is the policy of this Company to assure that applicants are employed, and that employees are treated during employment, without regard to their race, religion, sex, color, national origin, age or disability. Such action shall include: employment, upgrading, demotion, or transfer; recruitment or recruitment advertising; layoff or termination; rates of pay or other forms of compensation; and selection for training, including apprenticeship, pre-apprenticeship, and/or on-the-job training."

2. EEO Officer: The contractor will designate and make known to the contracting officers an EEO Officer who will have the responsibility for and must be capable of effectively administering and promoting an active EEO program and who must be assigned adequate authority and responsibility to do so.

3. Dissemination of Policy: All members of the contractor's staff who are authorized to hire, supervise, promote, and discharge employees, or who recommend such action, or who are substantially involved in such action, will be made fully cognizant of, and will implement, the contractor's EEO policy and contractual responsibilities to provide EEO in each grade and classification of employment. To ensure that the above agreement will be met, the following actions will be taken as a minimum:

a. Periodic meetings of supervisory and personnel office employees will be conducted before the start of work and then not less often than once every six months, at which time the contractor's EEO policy and its implementation will be reviewed and explained. The meetings will be conducted by the EEO Officer.

b. All new supervisory or personnel office employees will be given a thorough indoctrination by the EEO Officer, covering all major aspects of the contractor's EEO obligations within thirty days following their reporting for duty with the contractor.

c. All personnel who are engaged in direct recruitment for the project will be instructed by the EEO Officer in the contractor's procedures for locating and hiring minorities and women.

d. Notices and posters setting forth the contractor's EEO policy will be placed in areas readily accessible to employees, applicants for employment and potential employees.

e. The contractor's EEO policy and the procedures to implement such policy will be brought to the attention of employees by means of meetings, employee handbooks, or other appropriate means.

4. Recruitment: When advertising for employees, the contractor will include in all advertisements for employees the notation: "An Equal Opportunity Employer." All such advertisements will be placed in publications having a large circulation among minorities and women in the area from which the project work force would normally be derived.

a. The contractor will, unless precluded by a valid bargaining agreement, conduct systematic and direct recruitment through public and private employee referral sources likely to yield qualified minorities and women. To meet this requirement, the contractor will identify sources of potential minority group employees, and establish with such identified sources procedures whereby minority and women applicants may be referred to the contractor for employment consideration.

b. In the event the contractor has a valid bargaining agreement providing for exclusive hiring hall referrals, the contractor is expected to observe the provisions of that agreement to the extent that the system meets the contractor's compliance with EEO contract provisions. Where implementation of such an agreement has the effect of discriminating against minorities or women, or obligates the contractor to do the same, such implementation violates Federal nondiscrimination provisions.

c. The contractor will encourage its present employees to refer minorities and women as applicants for employment. Information and procedures with regard to referring such applicants will be discussed with employees.

5. Personnel Actions: Wages, working conditions, and employee benefits shall be established and administered, and personnel actions of every type, including hiring, upgrading, promotion, transfer, demotion, layoff, and termination, shall be taken without regard to race, color, religion, sex, national origin, age or disability. The following procedures shall be followed:

a. The contractor will conduct periodic inspections of project sites to insure that working conditions and employee facilities do not indicate discriminatory treatment of project site personnel.

b. The contractor will periodically evaluate the spread of wages paid within each classification to determine any evidence of discriminatory wage practices.

c. The contractor will periodically review selected personnel actions in depth to determine whether there is evidence of discrimination. Where evidence is found, the contractor will promptly take corrective action. If the review indicates that the discrimination may extend beyond the actions reviewed, such corrective action shall include all affected persons.

d. The contractor will promptly investigate all complaints of alleged discrimination made to the contractor in connection with its obligations under this contract, will attempt to resolve such complaints, and will take appropriate corrective action within a reasonable time. If the investigation indicates that the discrimination may affect persons other than the complainant, such corrective action shall include such other persons. Upon completion of each investigation, the contractor will inform every complainant of all of their avenues of appeal.

6. Training and Promotion:

a. The contractor will assist in locating, qualifying, and increasing the skills of minorities and women who are

applicants for employment or current employees. Such efforts should be aimed at developing full journey level status employees in the type of trade or job classification involved.

b. Consistent with the contractor's work force requirements and as permissible under Federal and State regulations, the contractor shall make full use of training programs, i.e., apprenticeship, and on-the-job training programs for the geographical area of contract performance. In the event a special provision for training is provided under this contract, this subparagraph will be superseded as indicated in the special provision. The contracting agency may reserve training positions for persons who receive welfare assistance in accordance with 23 U.S.C. 140(a).

c. The contractor will advise employees and applicants for employment of available training programs and entrance requirements for each.

d. The contractor will periodically review the training and promotion potential of employees who are minorities and women and will encourage eligible employees to apply for such training and promotion.

7. Unions: If the contractor relies in whole or in part upon unions as a source of employees, the contractor will use good faith efforts to obtain the cooperation of such unions to increase opportunities for minorities and women. Actions by the contractor, either directly or through a contractor's association acting as agent, will include the procedures set forth below:

a. The contractor will use good faith efforts to develop, in cooperation with the unions, joint training programs aimed toward qualifying more minorities and women for membership in the unions and increasing the skills of minorities and women so that they may qualify for higher paying employment.

b. The contractor will use good faith efforts to incorporate an EEO clause into each union agreement to the end that such union will be contractually bound to refer applicants without regard to their race, color, religion, sex, national origin, age or disability.

c. The contractor is to obtain information as to the referral practices and policies of the labor union except that to the extent such information is within the exclusive possession of the labor union and such labor union refuses to furnish such information to the contractor, the contractor shall so certify to the contracting agency and shall set forth what efforts have been made to obtain such information.

d. In the event the union is unable to provide the contractor with a reasonable flow of referrals within the time limit set forth in the collective bargaining agreement, the contractor will, through independent recruitment efforts, fill the employment vacancies without regard to race, color, religion, sex, national origin, age or disability; making full efforts to obtain qualified and/or qualifiable minorities and women. The failure of a union to provide sufficient referrals (even though it is obligated to provide exclusive referrals under the terms of a collective bargaining agreement) does not relieve the contractor from the requirements of this paragraph. In the event the union referral practice prevents the contractor from meeting the obligations pursuant to Executive Order 11246, as amended, and these special provisions, such contractor shall immediately notify the contracting agency.

8. Reasonable Accommodation for Applicants / Employees with Disabilities: The contractor must be familiar

with the requirements for and comply with the Americans with Disabilities Act and all rules and regulations established there under. Employers must provide reasonable accommodation in all employment activities unless to do so would cause an undue hardship.

9. Selection of Subcontractors, Procurement of Materials and Leasing of Equipment: The contractor shall not discriminate on the grounds of race, color, religion, sex, national origin, age or disability in the selection and retention of subcontractors, including procurement of materials and leases of equipment. The contractor shall take all necessary and reasonable steps to ensure nondiscrimination in the administration of this contract.

a. The contractor shall notify all potential subcontractors and suppliers and lessors of their EEO obligations under this contract.

b. The contractor will use good faith efforts to ensure subcontractor compliance with their EEO obligations.

10. Assurance Required by 49 CFR 26.13(b):

a. The requirements of 49 CFR Part 26 and the State DOT's U.S. DOT-approved DBE program are incorporated by reference.

b. The contractor or subcontractor shall not discriminate on the basis of race, color, national origin, or sex in the performance of this contract. The contractor shall carry out applicable requirements of 49 CFR Part 26 in the award and administration of DOT-assisted contracts. Failure by the contractor to carry out these requirements is a material breach of this contract, which may result in the termination of this contract or such other remedy as the contracting agency deems appropriate.

11. Records and Reports: The contractor shall keep such records as necessary to document compliance with the EEO requirements. Such records shall be retained for a period of three years following the date of the final payment to the contractor for all contract work and shall be available at reasonable times and places for inspection by authorized representatives of the contracting agency and the FHWA.

a. The records kept by the contractor shall document the following:

(1) The number and work hours of minority and non-minority group members and women employed in each work classification on the project;

(2) The progress and efforts being made in cooperation with unions, when applicable, to increase employment opportunities for minorities and women; and

(3) The progress and efforts being made in locating, hiring, training, qualifying, and upgrading minorities and women;

b. The contractors and subcontractors will submit an annual report to the contracting agency each July for the duration of the project, indicating the number of minority, women, and non-minority group employees currently engaged in each work classification required by the contract work. This information is to be reported on [Form FHWA-1391](#). The staffing data should represent the project work force on board in all or any part of the last payroll period preceding the end of July. If on-the-job training is being required by special provision, the contractor

will be required to collect and report training data. The employment data should reflect the work force on board during all or any part of the last payroll period preceding the end of July.

III. NONSEGREGATED FACILITIES

This provision is applicable to all Federal-aid construction contracts and to all related construction subcontracts of \$10,000 or more.

The contractor must ensure that facilities provided for employees are provided in such a manner that segregation on the basis of race, color, religion, sex, or national origin cannot result. The contractor may neither require such segregated use by written or oral policies nor tolerate such use by employee custom. The contractor's obligation extends further to ensure that its employees are not assigned to perform their services at any location, under the contractor's control, where the facilities are segregated. The term "facilities" includes waiting rooms, work areas, restaurants and other eating areas, time clocks, restrooms, washrooms, locker rooms, and other storage or dressing areas, parking lots, drinking fountains, recreation or entertainment areas, transportation, and housing provided for employees. The contractor shall provide separate or single-user restrooms and necessary dressing or sleeping areas to assure privacy between sexes.

IV. DAVIS-BACON AND RELATED ACT PROVISIONS

This section is applicable to all Federal-aid construction projects exceeding \$2,000 and to all related subcontracts and lower-tier subcontracts (regardless of subcontract size). The requirements apply to all projects located within the right-of-way of a roadway that is functionally classified as Federal-aid highway. This excludes roadways functionally classified as local roads or rural minor collectors, which are exempt. Contracting agencies may elect to apply these requirements to other projects.

The following provisions are from the U.S. Department of Labor regulations in 29 CFR 5.5 "Contract provisions and related matters" with minor revisions to conform to the FHWA-1273 format and FHWA program requirements.

1. Minimum wages

a. All laborers and mechanics employed or working upon the site of the work, will be paid unconditionally and not less often than once a week, and without subsequent deduction or rebate on any account (except such payroll deductions as are permitted by regulations issued by the Secretary of Labor under the Copeland Act (29 CFR part 3)), the full amount of wages and bona fide fringe benefits (or cash equivalents thereof) due at time of payment computed at rates not less than those contained in the wage determination of the Secretary of Labor which is attached hereto and made a part hereof, regardless of any contractual relationship which may be alleged to exist between the contractor and such laborers and mechanics.

Contributions made or costs reasonably anticipated for bona fide fringe benefits under section 1(b)(2) of the Davis-Bacon Act on behalf of laborers or mechanics are considered wages paid to such laborers or mechanics, subject to the provisions

of paragraph 1.d. of this section; also, regular contributions made or costs incurred for more than a weekly period (but not less often than quarterly) under plans, funds, or programs which cover the particular weekly period, are deemed to be constructively made or incurred during such weekly period. Such laborers and mechanics shall be paid the appropriate wage rate and fringe benefits on the wage determination for the classification of work actually performed, without regard to skill, except as provided in 29 CFR 5.5(a)(4). Laborers or mechanics performing work in more than one classification may be compensated at the rate specified for each classification for the time actually worked therein: Provided, That the employer's payroll records accurately set forth the time spent in each classification in which work is performed. The wage determination (including any additional classification and wage rates conformed under paragraph 1.b. of this section) and the Davis-Bacon poster (WH-1321) shall be posted at all times by the contractor and its subcontractors at the site of the work in a prominent and accessible place where it can be easily seen by the workers.

b.(1) The contracting officer shall require that any class of laborers or mechanics, including helpers, which is not listed in the wage determination and which is to be employed under the contract shall be classified in conformance with the wage determination. The contracting officer shall approve an additional classification and wage rate and fringe benefits therefore only when the following criteria have been met:

- (i) The work to be performed by the classification requested is not performed by a classification in the wage determination; and
- (ii) The classification is utilized in the area by the construction industry; and
- (iii) The proposed wage rate, including any bona fide fringe benefits, bears a reasonable relationship to the wage rates contained in the wage determination.

(2) If the contractor and the laborers and mechanics to be employed in the classification (if known), or their representatives, and the contracting officer agree on the classification and wage rate (including the amount designated for fringe benefits where appropriate), a report of the action taken shall be sent by the contracting officer to the Administrator of the Wage and Hour Division, Employment Standards Administration, U.S. Department of Labor, Washington, DC 20210. The Administrator, or an authorized representative, will approve, modify, or disapprove every additional classification action within 30 days of receipt and so advise the contracting officer or will notify the contracting officer within the 30-day period that additional time is necessary.

(3) In the event the contractor, the laborers or mechanics to be employed in the classification or their representatives, and the contracting officer do not agree on the proposed classification and wage rate (including the amount designated for fringe benefits, where appropriate), the contracting officer shall refer the questions, including the views of all interested parties and the recommendation of the contracting officer, to the Wage and Hour Administrator for determination. The Wage and Hour Administrator, or an authorized representative, will issue a determination within 30 days of receipt and so advise the contracting officer or

will notify the contracting officer within the 30-day period that additional time is necessary.

(4) The wage rate (including fringe benefits where appropriate) determined pursuant to paragraphs 1.b.(2) or 1.b.(3) of this section, shall be paid to all workers performing work in the classification under this contract from the first day on which work is performed in the classification.

c. Whenever the minimum wage rate prescribed in the contract for a class of laborers or mechanics includes a fringe benefit which is not expressed as an hourly rate, the contractor shall either pay the benefit as stated in the wage determination or shall pay another bona fide fringe benefit or an hourly cash equivalent thereof.

d. If the contractor does not make payments to a trustee or other third person, the contractor may consider as part of the wages of any laborer or mechanic the amount of any costs reasonably anticipated in providing bona fide fringe benefits under a plan or program. Provided, That the Secretary of Labor has found, upon the written request of the contractor, that the applicable standards of the Davis-Bacon Act have been met. The Secretary of Labor may require the contractor to set aside in a separate account assets for the meeting of obligations under the plan or program.

2. Withholding

The contracting agency shall upon its own action or upon written request of an authorized representative of the Department of Labor, withhold or cause to be withheld from the contractor under this contract, or any other Federal contract with the same prime contractor, or any other federally-assisted contract subject to Davis-Bacon prevailing wage requirements, which is held by the same prime contractor, so much of the accrued payments or advances as may be considered necessary to pay laborers and mechanics, including apprentices, trainees, and helpers, employed by the contractor or any subcontractor the full amount of wages required by the contract. In the event of failure to pay any laborer or mechanic, including any apprentice, trainee, or helper, employed or working on the site of the work, all or part of the wages required by the contract, the contracting agency may, after written notice to the contractor, take such action as may be necessary to cause the suspension of any further payment, advance, or guarantee of funds until such violations have ceased.

3. Payrolls and basic records

a. Payrolls and basic records relating thereto shall be maintained by the contractor during the course of the work and preserved for a period of three years thereafter for all laborers and mechanics working at the site of the work. Such records shall contain the name, address, and social security number of each such worker, his or her correct classification, hourly rates of wages paid (including rates of contributions or costs anticipated for bona fide fringe benefits or cash equivalents thereof of the types described in section 1(b)(2)(B) of the Davis-Bacon Act), daily and weekly number of hours worked, deductions made and actual wages paid. Whenever the Secretary of Labor has found under 29 CFR 5.5(a)(1)(iv) that the wages of any laborer or mechanic include the amount of any costs reasonably anticipated in providing benefits under a plan or program described in section 1(b)(2)(B) of the Davis-

Bacon Act, the contractor shall maintain records which show that the commitment to provide such benefits is enforceable, that the plan or program is financially responsible, and that the plan or program has been communicated in writing to the laborers or mechanics affected, and records which show the costs anticipated or the actual cost incurred in providing such benefits. Contractors employing apprentices or trainees under approved programs shall maintain written evidence of the registration of apprenticeship programs and certification of trainee programs, the registration of the apprentices and trainees, and the ratios and wage rates prescribed in the applicable programs.

b.(1) The contractor shall submit weekly for each week in which any contract work is performed a copy of all payrolls to the contracting agency. The payrolls submitted shall set out accurately and completely all of the information required to be maintained under 29 CFR 5.5(a)(3)(i), except that full social security numbers and home addresses shall not be included on weekly transmittals. Instead the payrolls shall only need to include an individually identifying number for each employee (e.g., the last four digits of the employee's social security number). The required weekly payroll information may be submitted in any form desired. Optional Form WH-347 is available for this purpose from the Wage and Hour Division Web site at <http://www.dol.gov/esa/whd/forms/wh347instr.htm> or its successor site. The prime contractor is responsible for the submission of copies of payrolls by all subcontractors. Contractors and subcontractors shall maintain the full social security number and current address of each covered worker, and shall provide them upon request to the contracting agency for transmission to the State DOT, the FHWA or the Wage and Hour Division of the Department of Labor for purposes of an investigation or audit of compliance with prevailing wage requirements. It is not a violation of this section for a prime contractor to require a subcontractor to provide addresses and social security numbers to the prime contractor for its own records, without weekly submission to the contracting agency..

(2) Each payroll submitted shall be accompanied by a "Statement of Compliance," signed by the contractor or subcontractor or his or her agent who pays or supervises the payment of the persons employed under the contract and shall certify the following:

(i) That the payroll for the payroll period contains the information required to be provided under §5.5 (a)(3)(ii) of Regulations, 29 CFR part 5, the appropriate information is being maintained under §5.5 (a)(3)(i) of Regulations, 29 CFR part 5, and that such information is correct and complete;

(ii) That each laborer or mechanic (including each helper, apprentice, and trainee) employed on the contract during the payroll period has been paid the full weekly wages earned, without rebate, either directly or indirectly, and that no deductions have been made either directly or indirectly from the full wages earned, other than permissible deductions as set forth in Regulations, 29 CFR part 3;

(iii) That each laborer or mechanic has been paid not less than the applicable wage rates and fringe benefits or cash equivalents for the classification of work performed, as specified in the applicable wage determination incorporated into the contract.

(3) The weekly submission of a properly executed certification set forth on the reverse side of Optional Form WH-347 shall satisfy the requirement for submission of the "Statement of Compliance" required by paragraph 3.b.(2) of this section.

(4) The falsification of any of the above certifications may subject the contractor or subcontractor to civil or criminal prosecution under section 1001 of title 18 and section 231 of title 31 of the United States Code.

c. The contractor or subcontractor shall make the records required under paragraph 3.a. of this section available for inspection, copying, or transcription by authorized representatives of the contracting agency, the State DOT, the FHWA, or the Department of Labor, and shall permit such representatives to interview employees during working hours on the job. If the contractor or subcontractor fails to submit the required records or to make them available, the FHWA may, after written notice to the contractor, the contracting agency or the State DOT, take such action as may be necessary to cause the suspension of any further payment, advance, or guarantee of funds. Furthermore, failure to submit the required records upon request or to make such records available may be grounds for debarment action pursuant to 29 CFR 5.12.

4. Apprentices and trainees

a. Apprentices (programs of the USDOL).

Apprentices will be permitted to work at less than the predetermined rate for the work they performed when they are employed pursuant to and individually registered in a bona fide apprenticeship program registered with the U.S. Department of Labor, Employment and Training Administration, Office of Apprenticeship Training, Employer and Labor Services, or with a State Apprenticeship Agency recognized by the Office, or if a person is employed in his or her first 90 days of probationary employment as an apprentice in such an apprenticeship program, who is not individually registered in the program, but who has been certified by the Office of Apprenticeship Training, Employer and Labor Services or a State Apprenticeship Agency (where appropriate) to be eligible for probationary employment as an apprentice.

The allowable ratio of apprentices to journeymen on the job site in any craft classification shall not be greater than the ratio permitted to the contractor as to the entire work force under the registered program. Any worker listed on a payroll at an apprentice wage rate, who is not registered or otherwise employed as stated above, shall be paid not less than the applicable wage rate on the wage determination for the classification of work actually performed. In addition, any apprentice performing work on the job site in excess of the ratio permitted under the registered program shall be paid not less than the applicable wage rate on the wage determination for the work actually performed. Where a contractor is performing construction on a project in a locality other than that in which its program is registered, the ratios and wage rates (expressed in percentages of the journeyman's hourly rate) specified in the contractor's or subcontractor's registered program shall be observed.

Every apprentice must be paid at not less than the rate specified in the registered program for the apprentice's level of progress, expressed as a percentage of the journeymen hourly

rate specified in the applicable wage determination. Apprentices shall be paid fringe benefits in accordance with the provisions of the apprenticeship program. If the apprenticeship program does not specify fringe benefits, apprentices must be paid the full amount of fringe benefits listed on the wage determination for the applicable classification. If the Administrator determines that a different practice prevails for the applicable apprentice classification, fringes shall be paid in accordance with that determination.

In the event the Office of Apprenticeship Training, Employer and Labor Services, or a State Apprenticeship Agency recognized by the Office, withdraws approval of an apprenticeship program, the contractor will no longer be permitted to utilize apprentices at less than the applicable predetermined rate for the work performed until an acceptable program is approved.

b. Trainees (programs of the USDOL).

Except as provided in 29 CFR 5.16, trainees will not be permitted to work at less than the predetermined rate for the work performed unless they are employed pursuant to and individually registered in a program which has received prior approval, evidenced by formal certification by the U.S. Department of Labor, Employment and Training Administration.

The ratio of trainees to journeymen on the job site shall not be greater than permitted under the plan approved by the Employment and Training Administration.

Every trainee must be paid at not less than the rate specified in the approved program for the trainee's level of progress, expressed as a percentage of the journeyman hourly rate specified in the applicable wage determination. Trainees shall be paid fringe benefits in accordance with the provisions of the trainee program. If the trainee program does not mention fringe benefits, trainees shall be paid the full amount of fringe benefits listed on the wage determination unless the Administrator of the Wage and Hour Division determines that there is an apprenticeship program associated with the corresponding journeyman wage rate on the wage determination which provides for less than full fringe benefits for apprentices. Any employee listed on the payroll at a trainee rate who is not registered and participating in a training plan approved by the Employment and Training Administration shall be paid not less than the applicable wage rate on the wage determination for the classification of work actually performed. In addition, any trainee performing work on the job site in excess of the ratio permitted under the registered program shall be paid not less than the applicable wage rate on the wage determination for the work actually performed.

In the event the Employment and Training Administration withdraws approval of a training program, the contractor will no longer be permitted to utilize trainees at less than the applicable predetermined rate for the work performed until an acceptable program is approved.

c. Equal employment opportunity. The utilization of apprentices, trainees and journeymen under this part shall be in conformity with the equal employment opportunity requirements of Executive Order 11246, as amended, and 29 CFR part 30.

d. Apprentices and Trainees (programs of the U.S. DOT).

Apprentices and trainees working under apprenticeship and skill training programs which have been certified by the Secretary of Transportation as promoting EEO in connection with Federal-aid highway construction programs are not subject to the requirements of paragraph 4 of this Section IV. The straight time hourly wage rates for apprentices and trainees under such programs will be established by the particular programs. The ratio of apprentices and trainees to journeymen shall not be greater than permitted by the terms of the particular program.

5. Compliance with Copeland Act requirements. The contractor shall comply with the requirements of 29 CFR part 3, which are incorporated by reference in this contract.

6. Subcontracts. The contractor or subcontractor shall insert Form FHWA-1273 in any subcontracts and also require the subcontractors to include Form FHWA-1273 in any lower tier subcontracts. The prime contractor shall be responsible for the compliance by any subcontractor or lower tier subcontractor with all the contract clauses in 29 CFR 5.5.

7. Contract termination: debarment. A breach of the contract clauses in 29 CFR 5.5 may be grounds for termination of the contract, and for debarment as a contractor and a subcontractor as provided in 29 CFR 5.12.

8. Compliance with Davis-Bacon and Related Act requirements. All rulings and interpretations of the Davis-Bacon and Related Acts contained in 29 CFR parts 1, 3, and 5 are herein incorporated by reference in this contract.

9. Disputes concerning labor standards. Disputes arising out of the labor standards provisions of this contract shall not be subject to the general disputes clause of this contract. Such disputes shall be resolved in accordance with the procedures of the Department of Labor set forth in 29 CFR parts 5, 6, and 7. Disputes within the meaning of this clause include disputes between the contractor (or any of its subcontractors) and the contracting agency, the U.S. Department of Labor, or the employees or their representatives.

10. Certification of eligibility.

a. By entering into this contract, the contractor certifies that neither it (nor he or she) nor any person or firm who has an interest in the contractor's firm is a person or firm ineligible to be awarded Government contracts by virtue of section 3(a) of the Davis-Bacon Act or 29 CFR 5.12(a)(1).

b. No part of this contract shall be subcontracted to any person or firm ineligible for award of a Government contract by virtue of section 3(a) of the Davis-Bacon Act or 29 CFR 5.12(a)(1).

c. The penalty for making false statements is prescribed in the U.S. Criminal Code, 18 U.S.C. 1001.

V. CONTRACT WORK HOURS AND SAFETY STANDARDS ACT

The following clauses apply to any Federal-aid construction contract in an amount in excess of \$100,000 and subject to the overtime provisions of the Contract Work Hours and Safety Standards Act. These clauses shall be inserted in addition to the clauses required by 29 CFR 5.5(a) or 29 CFR 4.6. As used in this paragraph, the terms laborers and mechanics include watchmen and guards.

1. Overtime requirements. No contractor or subcontractor contracting for any part of the contract work which may require or involve the employment of laborers or mechanics shall require or permit any such laborer or mechanic in any workweek in which he or she is employed on such work to work in excess of forty hours in such workweek unless such laborer or mechanic receives compensation at a rate not less than one and one-half times the basic rate of pay for all hours worked in excess of forty hours in such workweek.

2. Violation; liability for unpaid wages; liquidated damages. In the event of any violation of the clause set forth in paragraph (1.) of this section, the contractor and any subcontractor responsible therefor shall be liable for the unpaid wages. In addition, such contractor and subcontractor shall be liable to the United States (in the case of work done under contract for the District of Columbia or a territory, to such District or to such territory), for liquidated damages. Such liquidated damages shall be computed with respect to each individual laborer or mechanic, including watchmen and guards, employed in violation of the clause set forth in paragraph (1.) of this section, in the sum of \$10 for each calendar day on which such individual was required or permitted to work in excess of the standard workweek of forty hours without payment of the overtime wages required by the clause set forth in paragraph (1.) of this section.

3. Withholding for unpaid wages and liquidated damages. The FHWA or the contracting agency shall upon its own action or upon written request of an authorized representative of the Department of Labor withhold or cause to be withheld, from any moneys payable on account of work performed by the contractor or subcontractor under any such contract or any other Federal contract with the same prime contractor, or any other federally-assisted contract subject to the Contract Work Hours and Safety Standards Act, which is held by the same prime contractor, such sums as may be determined to be necessary to satisfy any liabilities of such contractor or subcontractor for unpaid wages and liquidated damages as provided in the clause set forth in paragraph (2.) of this section.

4. Subcontracts. The contractor or subcontractor shall insert in any subcontracts the clauses set forth in paragraph (1.) through (4.) of this section and also a clause requiring the subcontractors to include these clauses in any lower tier subcontracts. The prime contractor shall be responsible for compliance by any subcontractor or lower tier subcontractor with the clauses set forth in paragraphs (1.) through (4.) of this section.

VI. SUBLETTING OR ASSIGNING THE CONTRACT

This provision is applicable to all Federal-aid construction contracts on the National Highway System.

1. The contractor shall perform with its own organization contract work amounting to not less than 30 percent (or a greater percentage if specified elsewhere in the contract) of the total original contract price, excluding any specialty items designated by the contracting agency. Specialty items may be performed by subcontract and the amount of any such specialty items performed may be deducted from the total original contract price before computing the amount of work required to be performed by the contractor's own organization (23 CFR 635.116).

a. The term "perform work with its own organization" refers to workers employed or leased by the prime contractor, and equipment owned or rented by the prime contractor, with or without operators. Such term does not include employees or equipment of a subcontractor or lower tier subcontractor, agents of the prime contractor, or any other assignees. The term may include payments for the costs of hiring leased employees from an employee leasing firm meeting all relevant Federal and State regulatory requirements. Leased employees may only be included in this term if the prime contractor meets all of the following conditions:

- (1) the prime contractor maintains control over the supervision of the day-to-day activities of the leased employees;
- (2) the prime contractor remains responsible for the quality of the work of the leased employees;
- (3) the prime contractor retains all power to accept or exclude individual employees from work on the project; and
- (4) the prime contractor remains ultimately responsible for the payment of predetermined minimum wages, the submission of payrolls, statements of compliance and all other Federal regulatory requirements.

b. "Specialty Items" shall be construed to be limited to work that requires highly specialized knowledge, abilities, or equipment not ordinarily available in the type of contracting organizations qualified and expected to bid or propose on the contract as a whole and in general are to be limited to minor components of the overall contract.

2. The contract amount upon which the requirements set forth in paragraph (1) of Section VI is computed includes the cost of material and manufactured products which are to be purchased or produced by the contractor under the contract provisions.

3. The contractor shall furnish (a) a competent superintendent or supervisor who is employed by the firm, has full authority to direct performance of the work in accordance with the contract requirements, and is in charge of all construction operations (regardless of who performs the work) and (b) such other of its own organizational resources (supervision, management, and engineering services) as the contracting officer determines is necessary to assure the performance of the contract.

4. No portion of the contract shall be sublet, assigned or otherwise disposed of except with the written consent of the contracting officer, or authorized representative, and such consent when given shall not be construed to relieve the contractor of any responsibility for the fulfillment of the contract. Written consent will be given only after the contracting agency has assured that each subcontract is

evidenced in writing and that it contains all pertinent provisions and requirements of the prime contract.

5. The 30% self-performance requirement of paragraph (1) is not applicable to design-build contracts; however, contracting agencies may establish their own self-performance requirements.

VII. SAFETY: ACCIDENT PREVENTION

This provision is applicable to all Federal-aid construction contracts and to all related subcontracts.

1. In the performance of this contract the contractor shall comply with all applicable Federal, State, and local laws governing safety, health, and sanitation (23 CFR 635). The contractor shall provide all safeguards, safety devices and protective equipment and take any other needed actions as it determines, or as the contracting officer may determine, to be reasonably necessary to protect the life and health of employees on the job and the safety of the public and to protect property in connection with the performance of the work covered by the contract.

2. It is a condition of this contract, and shall be made a condition of each subcontract, which the contractor enters into pursuant to this contract, that the contractor and any subcontractor shall not permit any employee, in performance of the contract, to work in surroundings or under conditions which are unsanitary, hazardous or dangerous to his/her health or safety, as determined under construction safety and health standards (29 CFR 1926) promulgated by the Secretary of Labor, in accordance with Section 107 of the Contract Work Hours and Safety Standards Act (40 U.S.C. 3704).

3. Pursuant to 29 CFR 1926.3, it is a condition of this contract that the Secretary of Labor or authorized representative thereof, shall have right of entry to any site of contract performance to inspect or investigate the matter of compliance with the construction safety and health standards and to carry out the duties of the Secretary under Section 107 of the Contract Work Hours and Safety Standards Act (40 U.S.C.3704).

VIII. FALSE STATEMENTS CONCERNING HIGHWAY PROJECTS

This provision is applicable to all Federal-aid construction contracts and to all related subcontracts.

In order to assure high quality and durable construction in conformity with approved plans and specifications and a high degree of reliability on statements and representations made by engineers, contractors, suppliers, and workers on Federal-aid highway projects, it is essential that all persons concerned with the project perform their functions as carefully, thoroughly, and honestly as possible. Willful falsification, distortion, or misrepresentation with respect to any facts related to the project is a violation of Federal law. To prevent any misunderstanding regarding the seriousness of these and similar acts, Form FHWA-1022 shall be posted on each Federal-aid highway project (23 CFR 635) in one or more places where it is readily available to all persons concerned with the project:

18 U.S.C. 1020 reads as follows:

"Whoever, being an officer, agent, or employee of the United States, or of any State or Territory, or whoever, whether a person, association, firm, or corporation, knowingly makes any false statement, false representation, or false report as to the character, quality, quantity, or cost of the material used or to be used, or the quantity or quality of the work performed or to be performed, or the cost thereof in connection with the submission of plans, maps, specifications, contracts, or costs of construction on any highway or related project submitted for approval to the Secretary of Transportation; or

Whoever knowingly makes any false statement, false representation, false report or false claim with respect to the character, quality, quantity, or cost of any work performed or to be performed, or materials furnished or to be furnished, in connection with the construction of any highway or related project approved by the Secretary of Transportation; or

Whoever knowingly makes any false statement or false representation as to material fact in any statement, certificate, or report submitted pursuant to provisions of the Federal-aid Roads Act approved July 1, 1916, (39 Stat. 355), as amended and supplemented;

Shall be fined under this title or imprisoned not more than 5 years or both."

IX. IMPLEMENTATION OF CLEAN AIR ACT AND FEDERAL WATER POLLUTION CONTROL ACT

This provision is applicable to all Federal-aid construction contracts and to all related subcontracts.

By submission of this bid/proposal or the execution of this contract, or subcontract, as appropriate, the bidder, proposer, Federal-aid construction contractor, or subcontractor, as appropriate, will be deemed to have stipulated as follows:

1. That any person who is or will be utilized in the performance of this contract is not prohibited from receiving an award due to a violation of Section 508 of the Clean Water Act or Section 306 of the Clean Air Act.

2. That the contractor agrees to include or cause to be included the requirements of paragraph (1) of this Section X in every subcontract, and further agrees to take such action as the contracting agency may direct as a means of enforcing such requirements.

X. CERTIFICATION REGARDING DEBARMENT, SUSPENSION, INELIGIBILITY AND VOLUNTARY EXCLUSION

This provision is applicable to all Federal-aid construction contracts, design-build contracts, subcontracts, lower-tier subcontracts, purchase orders, lease agreements, consultant contracts or any other covered transaction requiring FHWA approval or that is estimated to cost \$25,000 or more – as defined in 2 CFR Parts 180 and 1200.

1. Instructions for Certification – First Tier Participants:

a. By signing and submitting this proposal, the prospective first tier participant is providing the certification set out below.

b. The inability of a person to provide the certification set out below will not necessarily result in denial of participation in this

covered transaction. The prospective first tier participant shall submit an explanation of why it cannot provide the certification set out below. The certification or explanation will be considered in connection with the department or agency's determination whether to enter into this transaction. However, failure of the prospective first tier participant to furnish a certification or an explanation shall disqualify such a person from participation in this transaction.

c. The certification in this clause is a material representation of fact upon which reliance was placed when the contracting agency determined to enter into this transaction. If it is later determined that the prospective participant knowingly rendered an erroneous certification, in addition to other remedies available to the Federal Government, the contracting agency may terminate this transaction for cause of default.

d. The prospective first tier participant shall provide immediate written notice to the contracting agency to whom this proposal is submitted if any time the prospective first tier participant learns that its certification was erroneous when submitted or has become erroneous by reason of changed circumstances.

e. The terms "covered transaction," "debarred," "suspended," "ineligible," "participant," "person," "principal," and "voluntarily excluded," as used in this clause, are defined in 2 CFR Parts 180 and 1200. "First Tier Covered Transactions" refers to any covered transaction between a grantee or subgrantee of Federal funds and a participant (such as the prime or general contract). "Lower Tier Covered Transactions" refers to any covered transaction under a First Tier Covered Transaction (such as subcontracts). "First Tier Participant" refers to the participant who has entered into a covered transaction with a grantee or subgrantee of Federal funds (such as the prime or general contractor). "Lower Tier Participant" refers any participant who has entered into a covered transaction with a First Tier Participant or other Lower Tier Participants (such as subcontractors and suppliers).

f. The prospective first tier participant agrees by submitting this proposal that, should the proposed covered transaction be entered into, it shall not knowingly enter into any lower tier covered transaction with a person who is debarred, suspended, declared ineligible, or voluntarily excluded from participation in this covered transaction, unless authorized by the department or agency entering into this transaction.

g. The prospective first tier participant further agrees by submitting this proposal that it will include the clause titled "Certification Regarding Debarment, Suspension, Ineligibility and Voluntary Exclusion-Lower Tier Covered Transactions," provided by the department or contracting agency, entering into this covered transaction, without modification, in all lower tier covered transactions and in all solicitations for lower tier covered transactions exceeding the \$25,000 threshold.

h. A participant in a covered transaction may rely upon a certification of a prospective participant in a lower tier covered transaction that is not debarred, suspended, ineligible, or voluntarily excluded from the covered transaction, unless it knows that the certification is erroneous. A participant is responsible for ensuring that its principals are not suspended, debarred, or otherwise ineligible to participate in covered transactions. To verify the eligibility of its principals, as well as the eligibility of any lower tier prospective participants, each participant may, but is not required to, check the Excluded Parties List System website (<https://www.epls.gov/>), which is compiled by the General Services Administration.

i. Nothing contained in the foregoing shall be construed to require the establishment of a system of records in order to render in good faith the certification required by this clause. The knowledge and information of the prospective participant is not required to exceed that which is normally possessed by a prudent person in the ordinary course of business dealings.

j. Except for transactions authorized under paragraph (f) of these instructions, if a participant in a covered transaction knowingly enters into a lower tier covered transaction with a person who is suspended, debarred, ineligible, or voluntarily excluded from participation in this transaction, in addition to other remedies available to the Federal Government, the department or agency may terminate this transaction for cause or default.

* * * * *

2. Certification Regarding Debarment, Suspension, Ineligibility and Voluntary Exclusion – First Tier Participants:

a. The prospective first tier participant certifies to the best of its knowledge and belief, that it and its principals:

(1) Are not presently debarred, suspended, proposed for debarment, declared ineligible, or voluntarily excluded from participating in covered transactions by any Federal department or agency;

(2) Have not within a three-year period preceding this proposal been convicted of or had a civil judgment rendered against them for commission of fraud or a criminal offense in connection with obtaining, attempting to obtain, or performing a public (Federal, State or local) transaction or contract under a public transaction; violation of Federal or State antitrust statutes or commission of embezzlement, theft, forgery, bribery, falsification or destruction of records, making false statements, or receiving stolen property;

(3) Are not presently indicted for or otherwise criminally or civilly charged by a governmental entity (Federal, State or local) with commission of any of the offenses enumerated in paragraph (a)(2) of this certification; and

(4) Have not within a three-year period preceding this application/proposal had one or more public transactions (Federal, State or local) terminated for cause or default.

b. Where the prospective participant is unable to certify to any of the statements in this certification, such prospective participant shall attach an explanation to this proposal.

2. Instructions for Certification - Lower Tier Participants:

(Applicable to all subcontracts, purchase orders and other lower tier transactions requiring prior FHWA approval or estimated to cost \$25,000 or more - 2 CFR Parts 180 and 1200)

a. By signing and submitting this proposal, the prospective lower tier is providing the certification set out below.

b. The certification in this clause is a material representation of fact upon which reliance was placed when this transaction was entered into. If it is later determined that the prospective lower tier participant knowingly rendered an erroneous certification, in addition to other remedies available to the Federal Government, the department, or agency with which

this transaction originated may pursue available remedies, including suspension and/or debarment.

c. The prospective lower tier participant shall provide immediate written notice to the person to which this proposal is submitted if at any time the prospective lower tier participant learns that its certification was erroneous by reason of changed circumstances.

d. The terms "covered transaction," "debarred," "suspended," "ineligible," "participant," "person," "principal," and "voluntarily excluded," as used in this clause, are defined in 2 CFR Parts 180 and 1200. You may contact the person to which this proposal is submitted for assistance in obtaining a copy of those regulations. "First Tier Covered Transactions" refers to any covered transaction between a grantee or subgrantee of Federal funds and a participant (such as the prime or general contract). "Lower Tier Covered Transactions" refers to any covered transaction under a First Tier Covered Transaction (such as subcontracts). "First Tier Participant" refers to the participant who has entered into a covered transaction with a grantee or subgrantee of Federal funds (such as the prime or general contractor). "Lower Tier Participant" refers any participant who has entered into a covered transaction with a First Tier Participant or other Lower Tier Participants (such as subcontractors and suppliers).

e. The prospective lower tier participant agrees by submitting this proposal that, should the proposed covered transaction be entered into, it shall not knowingly enter into any lower tier covered transaction with a person who is debarred, suspended, declared ineligible, or voluntarily excluded from participation in this covered transaction, unless authorized by the department or agency with which this transaction originated.

f. The prospective lower tier participant further agrees by submitting this proposal that it will include this clause titled "Certification Regarding Debarment, Suspension, Ineligibility and Voluntary Exclusion-Lower Tier Covered Transaction," without modification, in all lower tier covered transactions and in all solicitations for lower tier covered transactions exceeding the \$25,000 threshold.

g. A participant in a covered transaction may rely upon a certification of a prospective participant in a lower tier covered transaction that is not debarred, suspended, ineligible, or voluntarily excluded from the covered transaction, unless it knows that the certification is erroneous. A participant is responsible for ensuring that its principals are not suspended, debarred, or otherwise ineligible to participate in covered transactions. To verify the eligibility of its principals, as well as the eligibility of any lower tier prospective participants, each participant may, but is not required to, check the Excluded Parties List System website (<https://www.epls.gov/>), which is compiled by the General Services Administration.

h. Nothing contained in the foregoing shall be construed to require establishment of a system of records in order to render in good faith the certification required by this clause. The knowledge and information of participant is not required to exceed that which is normally possessed by a prudent person in the ordinary course of business dealings.

i. Except for transactions authorized under paragraph e of these instructions, if a participant in a covered transaction knowingly enters into a lower tier covered transaction with a person who is suspended, debarred, ineligible, or voluntarily excluded from participation in this transaction, in addition to other remedies available to the Federal Government, the

department or agency with which this transaction originated may pursue available remedies, including suspension and/or debarment.

* * * * *

Certification Regarding Debarment, Suspension, Ineligibility and Voluntary Exclusion--Lower Tier Participants:

1. The prospective lower tier participant certifies, by submission of this proposal, that neither it nor its principals is presently debarred, suspended, proposed for debarment, declared ineligible, or voluntarily excluded from participating in covered transactions by any Federal department or agency.

2. Where the prospective lower tier participant is unable to certify to any of the statements in this certification, such prospective participant shall attach an explanation to this proposal.

* * * * *

XI. CERTIFICATION REGARDING USE OF CONTRACT FUNDS FOR LOBBYING

This provision is applicable to all Federal-aid construction contracts and to all related subcontracts which exceed \$100,000 (49 CFR 20).

1. The prospective participant certifies, by signing and submitting this bid or proposal, to the best of his or her knowledge and belief, that:

a. No Federal appropriated funds have been paid or will be paid, by or on behalf of the undersigned, to any person for influencing or attempting to influence an officer or employee of any Federal agency, a Member of Congress, an officer or employee of Congress, or an employee of a Member of Congress in connection with the awarding of any Federal contract, the making of any Federal grant, the making of any Federal loan, the entering into of any cooperative agreement, and the extension, continuation, renewal, amendment, or modification of any Federal contract, grant, loan, or cooperative agreement.

b. If any funds other than Federal appropriated funds have been paid or will be paid to any person for influencing or attempting to influence an officer or employee of any Federal agency, a Member of Congress, an officer or employee of Congress, or an employee of a Member of Congress in connection with this Federal contract, grant, loan, or cooperative agreement, the undersigned shall complete and submit Standard Form-LLL, "Disclosure Form to Report Lobbying," in accordance with its instructions.

2. This certification is a material representation of fact upon which reliance was placed when this transaction was made or entered into. Submission of this certification is a prerequisite for making or entering into this transaction imposed by 31 U.S.C. 1352. Any person who fails to file the required certification shall be subject to a civil penalty of not less than \$10,000 and not more than \$100,000 for each such failure.

3. The prospective participant also agrees by submitting its bid or proposal that the participant shall require that the language of this certification be included in all lower tier subcontracts, which exceed \$100,000 and that all such recipients shall certify and disclose accordingly.

**ATTACHMENT A - EMPLOYMENT AND MATERIALS
PREFERENCE FOR APPALACHIAN DEVELOPMENT
HIGHWAY SYSTEM OR APPALACHIAN LOCAL ACCESS
ROAD CONTRACTS**

This provision is applicable to all Federal-aid projects funded under the Appalachian Regional Development Act of 1965.

1. During the performance of this contract, the contractor undertaking to do work which is, or reasonably may be, done as on-site work, shall give preference to qualified persons who regularly reside in the labor area as designated by the DOL wherein the contract work is situated, or the subregion, or the Appalachian counties of the State wherein the contract work is situated, except:

a. To the extent that qualified persons regularly residing in the area are not available.

b. For the reasonable needs of the contractor to employ supervisory or specially experienced personnel necessary to assure an efficient execution of the contract work.

c. For the obligation of the contractor to offer employment to present or former employees as the result of a lawful collective bargaining contract, provided that the number of nonresident persons employed under this subparagraph (1c) shall not exceed 20 percent of the total number of employees employed by the contractor on the contract work, except as provided in subparagraph (4) below.

2. The contractor shall place a job order with the State Employment Service indicating (a) the classifications of the laborers, mechanics and other employees required to perform the contract work, (b) the number of employees required in each classification, (c) the date on which the participant estimates such employees will be required, and (d) any other pertinent information required by the State Employment Service to complete the job order form. The job order may be placed with the State Employment Service in writing or by telephone. If during the course of the contract work, the information submitted by the contractor in the original job order is substantially modified, the participant shall promptly notify the State Employment Service.

3. The contractor shall give full consideration to all qualified job applicants referred to him by the State Employment Service. The contractor is not required to grant employment to any job applicants who, in his opinion, are not qualified to perform the classification of work required.

4. If, within one week following the placing of a job order by the contractor with the State Employment Service, the State Employment Service is unable to refer any qualified job applicants to the contractor, or less than the number requested, the State Employment Service will forward a certificate to the contractor indicating the unavailability of applicants. Such certificate shall be made a part of the contractor's permanent project records. Upon receipt of this certificate, the contractor may employ persons who do not normally reside in the labor area to fill positions covered by the certificate, notwithstanding the provisions of subparagraph (1c) above.

5. The provisions of 23 CFR 633.207(e) allow the contracting agency to provide a contractual preference for the use of mineral resource materials native to the Appalachian region.

6. The contractor shall include the provisions of Sections 1 through 4 of this Attachment A in every subcontract for work which is, or reasonably may be, done as on-site work.

**KENTUCKY TRANSPORTATION CABINET
DEPARTMENT OF HIGHWAYS**

**EMPLOYMENT REQUIREMENTS
RELATING TO
NONDISCRIMINATION OF EMPLOYEES
(APPLICABLE TO FEDERAL-AID SYSTEM CONTRACTS)**

**AN ACT OF THE KENTUCKY GENERAL ASSEMBLY
TO PREVENT DISCRIMINATION IN EMPLOYMENT**

**KRS CHAPTER 344
EFFECTIVE JUNE 16, 1972**

The contract on this project, in accordance with KRS Chapter 344, provides that during the performance of this contract, the contractor agrees as follows:

1. The contractor shall not fail or refuse to hire, or shall not discharge any individual, or otherwise discriminate against an individual with respect to his compensation, terms, conditions, or privileges of employment, because of such individual's race, color, religion, national origin, sex, disability or age (forty and above); or limit, segregate, or classify his employees in any way which would deprive or tend to deprive an individual of employment opportunities or otherwise adversely affect his status as an employee, because of such individual's race, color, religion, national origin, sex, disability or age forty (40) and over. The contractor agrees to post in conspicuous places, available to employees and applicants for employment, notices to be provided setting forth the provisions of this nondiscrimination clause.

2. The contractor shall not print or publish or cause to be printed or published a notice or advertisement relating to employment by such an employer or membership in or any classification or referral for employment by the employment agency, indicating any preference, limitation, specification, or discrimination, based on race, color, religion, national origin, sex, or age forty (40) and over, or because the person is a qualified individual with a disability, except that such a notice or advertisement may indicate a preference, limitation, or specification based on religion, national origin, sex, or age forty (40) and over, or because the person is a qualified individual with a disability, when religion, national origin, sex, or age forty (40) and over, or because the person is a qualified individual with a disability, is a bona fide occupational qualification for employment.

3. If the contractor is in control of apprenticeship or other training or retraining, including on-the-job training programs, he shall not discriminate against an individual because of his race, color, religion, national origin, sex, disability or age forty (40) and over, in admission to, or employment in any program established to provide apprenticeship or other training.

4. The contractor will send to each labor union or representative of workers with which he has a collective bargaining agreement or other contract or understanding, a notice to be provided advising the said labor union or workers' representative of the contractor's commitments under this section, and shall post copies of the notice in conspicuous places available to employees and applicants for employment. The contractor will take such action with respect to any subcontract or purchase order as the administering agency may direct as a means of enforcing such provisions, including sanctions for non-compliance.

Revised: January 25, 2017

Standard Title VI/Non-Discrimination Assurances

During the performance of this contract, the contractor, for itself, its assignees, and successors in interest (hereinafter referred to as the "contractor") agrees as follows:

1. **Compliance with Regulations:** The contractor (hereinafter includes consultants) will comply with the Acts and the Regulations relative to Non-discrimination in Federally-assisted programs of the U.S. Department of Transportation, **Federal Highway Administration**, as they may be amended from time to time, which are herein incorporated by reference and made a part of this contract.
2. **Non-discrimination:** The contractor, with regard to the work performed by it during the contract, will not discriminate on the grounds of race, color, or national origin in the selection and retention of subcontractors, including procurements of materials and leases of equipment. The contractor will not participate directly or indirectly in the discrimination prohibited by the Acts and the Regulations, including employment practices when the contract covers any activity, project, or program set forth in Appendix B of 49 CFR Part 21.
3. **Solicitations for Subcontracts, Including Procurements of Materials and Equipment:** In all solicitations, either by competitive bidding, or negotiation made by the contractor for work to be performed under a subcontract, including procurements of materials, or leases of equipment, each potential subcontractor or supplier will be notified by the contractor of the contractor's obligations under this contract and the Acts and the Regulations relative to Non-discrimination on the grounds of race, color, or national origin.
4. **Information and Reports:** The contractor will provide all information and reports required by the Acts, the Regulations, and directives issued pursuant thereto and will permit access to its books, records, accounts, other sources of information, and its facilities as may be determined by the Recipient or the **Federal Highway Administration** to be pertinent to ascertain compliance with such Acts, Regulations, and instructions. Where any information required of a contractor is in the exclusive possession of another who fails or refuses to furnish the information, the contractor will so certify to the Recipient or the **Federal Highway Administration**, as appropriate, and will set forth what efforts it has made to obtain the information.
5. **Sanctions for Noncompliance:** In the event of a contractor's noncompliance with the Non-discrimination provisions of this contract, the Recipient will impose such contract sanctions as it or the **Federal Highway Administration** may determine to be appropriate, including, but not limited to:
 - a. withholding payments to the contractor under the contract until the contractor complies; and/or
 - b. cancelling, terminating, or suspending a contract, in whole or in part.
6. **Incorporation of Provisions:** The contractor will include the provisions of paragraphs one through six in every subcontract, including procurements of materials and leases of equipment, unless exempt by the Acts, the Regulations and directives issued pursuant thereto. The contractor will take action with respect to any subcontract or procurement as the Recipient or the **Federal Highway Administration** may direct as a means of enforcing such provisions including sanctions for noncompliance. Provided, that if the contractor becomes involved in, or is threatened with litigation by a subcontractor, or supplier because of such direction, the contractor may request the Recipient to enter into any litigation to protect the interests of the Recipient. In addition, the contractor may request the United States to enter into the litigation to protect the interests of the United States.

Standard Title VI/Non-Discrimination Statutes and Authorities

During the performance of this contract, the contractor, for itself, its assignees, and successors in interest (hereinafter referred to as the “contractor”) agrees to comply with the following non-discrimination statutes and authorities; including but not limited to:

- Title VI of the Civil Rights Act of 1964 (42 U.S.C. § 2000d *et seq.*, 78 stat. 252), (prohibits discrimination on the basis of race, color, national origin); and 49 CFR Part 21;
- The Uniform Relocation Assistance and Real Property Acquisition Policies Act of 1970, (42 U.S.C. § 4601), (prohibits unfair treatment of persons displaced or whose property has been acquired because of Federal or Federal-aid programs and projects);
- Federal-Aid Highway Act of 1973, (23 U.S.C. § 324 *et seq.*), (prohibits discrimination on the basis of sex);
- Section 504 of the Rehabilitation Act of 1973, (29 U.S.C. § 794 *et seq.*), as amended, (prohibits discrimination on the basis of disability); and 49 CFR Part 27;
- The Age Discrimination Act of 1975, as amended, (42 U.S.C. § 6101 *et seq.*), (prohibits discrimination on the basis of age);
- Airport and Airway Improvement Act of 1982, (49 USC § 471, Section 47123), as amended, (prohibits discrimination based on race, creed, color, national origin, or sex);
- The Civil Rights Restoration Act of 1987, (PL 100-209), (Broadened the scope, coverage and applicability of Title VI of the Civil Rights Act of 1964, The Age Discrimination Act of 1975 and Section 504 of the Rehabilitation Act of 1973, by expanding the definition of the terms “programs or activities” to include all of the programs or activities of the Federal-aid recipients, sub-recipients and contractors, whether such programs or activities are Federally funded or not);
- Titles II and III of the Americans with Disabilities Act, which prohibit discrimination on the basis of disability in the operation of public entities, public and private transportation systems, places of public accommodation, and certain testing entities (42 U.S.C. §§ 12131 -- 12189) as implemented by Department of Transportation regulations at 49 C.F.R. parts 37 and 38;
- The Federal Aviation Administration’s Non-discrimination statute (49 U.S.C. § 47123) (prohibits discrimination on the basis of race, color, national origin, and sex);
- Executive Order 12898, Federal Actions to Address Environmental Justice in Minority Populations and Low-Income Populations, which ensures non-discrimination against minority populations by discouraging programs, policies, and activities with disproportionately high and adverse human health or environmental effects on minority and low-income populations;
- Executive Order 13166, Improving Access to Services for Persons with Limited English Proficiency, and resulting agency guidance, national origin discrimination includes discrimination because of limited English proficiency (LEP). To ensure compliance with Title VI, you must take reasonable steps to ensure that LEP persons have meaningful access to your programs (70 Fed. Reg. at 74087 to 74100);
- Title IX of the Education Amendments of 1972, as amended, which prohibits you from discriminating because of sex in education programs or activities (20 U.S.C. 1681 *et seq.*)

EXECUTIVE BRANCH CODE OF ETHICS

In the 1992 regular legislative session, the General Assembly passed and Governor Brereton Jones signed Senate Bill 63 (codified as KRS 11A), the Executive Branch Code of Ethics, which states, in part:

KRS 11A.040 (7) provides:

No present or former public servant shall, within six (6) months following termination of his office or employment, accept employment, compensation, or other economic benefit from any person or business that contracts or does business with, or is regulated by, the state in matters in which he was directly involved during the last thirty-six (36) months of his tenure. This provision shall not prohibit an individual from returning to the same business, firm, occupation, or profession in which he was involved prior to taking office or beginning his term of employment, or for which he received, prior to his state employment, a professional degree or license, provided that, for a period of six (6) months, he personally refrains from working on any matter in which he was directly involved during the last thirty-six (36) months of his tenure in state government. This subsection shall not prohibit the performance of ministerial functions, including but not limited to filing tax returns, filing applications for permits or licenses, or filing incorporation papers, nor shall it prohibit the former officer or public servant from receiving public funds disbursed through entitlement programs.

KRS 11A.040 (9) states:

A former public servant shall not represent a person or business before a state agency in a matter in which the former public servant was directly involved during the last thirty-six (36) months of his tenure, for a period of one (1) year after the latter of:

- a) The date of leaving office or termination of employment; or
- b) The date the term of office expires to which the public servant was elected.

This law is intended to promote public confidence in the integrity of state government and to declare as public policy the idea that state employees should view their work as a public trust and not as a way to obtain private benefits.

If you have worked for the executive branch of state government within the past six months, you may be subject to the law's prohibitions. The law's applicability may be different if you hold elected office or are contemplating representation of another before a state agency.

Also, if you are affiliated with a firm which does business with the state and which employs former state executive-branch employees, you should be aware that the law may apply to them.

In case of doubt, the law permits you to request an advisory opinion from the Executive Branch Ethics Commission, 3 Fountain Place, Frankfort, Kentucky 40601; telephone (502) 564-7954.

**TRANSPORTATION CABINET
PROJECT WAGE RATES**

KENTON COUNTY, NHPP IM 0758 (107)

Lexington-Cincinnati Road (I-71/I-75) Brent Spence Bridge over Ohio River

NOTICE:

There are three (3) sets of wage rates established for this project. The contractor shall use federal wage rate decision number OH20210001 for roadway and bridge work performed in Hamilton, Ohio. Wage rate decision number KY20210073 shall apply for bridge work performed in Kentucky. Wage rate decision number KY20210039 shall apply for all other road work performed in Kentucky.

"General Decision Number: OH20210001 01/01/2021

Superseded General Decision Number: OH20200001

State: Ohio

Construction Types: Heavy and Highway

Counties: Ohio Statewide.

Heavy and Highway Construction Projects

Note: Under Executive Order (EO) 13658, an hourly minimum wage of \$10.95 for calendar year 2021 applies to all contracts subject to the Davis-Bacon Act for which the contract is awarded (and any solicitation was issued) on or after January 1, 2015. If this contract is covered by the EO, the contractor must pay all workers in any classification listed on this wage determination at least \$10.95 per hour (or the applicable wage rate listed on this wage determination, if it is higher) for all hours spent performing on the contract in calendar year 2021. If this contract is covered by the EO and a classification considered necessary for performance of work on the contract does not appear on this wage determination, the contractor must pay workers in that classification at least the wage rate determined through the conformance process set forth in 29 CFR 5.5(a)(1)(ii) (or the EO minimum wage rate, if it is higher than the conformed wage rate). The EO minimum wage rate will be adjusted annually. Please note that this EO applies to the above-mentioned types of contracts entered into by the federal government that are subject to the Davis-Bacon Act itself, but it does not apply to contracts subject only to the Davis-Bacon Related Acts, including those set forth at 29 CFR 5.1(a)(2)-(60). Additional information on contractor requirements and worker protections under the EO is available at www.dol.gov/whd/govcontracts.

Modification Number	Publication Date
0	01/01/2021

BROH0001-001 06/01/2019

DEFIANCE, FULTON (Excluding Fulton, Amboy & Swan Creek Townships), HENRY (Excluding Monroe, Bartlow, Liberty, Washington, Richfield, Marion, Damascus & Townships & that part of Harrison Township outside corporate limits of city of Napoleon), PAULDING, PUTNAM and WILLIAMS COUNTIES

	Rates	Fringes
Bricklayer, Stonemason.....	\$ 29.34	16.11

BROH0001-004 06/01/2019

	Rates	Fringes
CEMENT MASON/CONCRETE FINISHER...	\$ 29.34	16.11

BROH0003-002 06/01/2019

FULTON (Townships of Amboy, Swan Creek & Fulton), HENRY (Townships of Washington, Damascus, Richfield, Bartlow, Liberty, Harrison, Monroe, & Marion), LUCAS and WOOD (Townships of Perrysburg, Ross, Lake, Troy, Freedom, Montgomery, Webster, Center, Portage, Middleton, Plain, Liberty, Henry, Washington, Weston, Milton, Jackson & Grand Rapids) COUNTIES

	Rates	Fringes
Bricklayer, Stonemason.....	\$ 29.34	16.11

BROH0005-003 05/01/2019

CUYAHOGA, LORAIN & MEDINA (Hinckley, Granger, Brunswick, Liverpool, Montville, York, Homer, Harrisville, Chatham, Litchfield & Spencer Townships and the city of Medina)

	Rates	Fringes
BRICKLAYER		
BRICKLAYERS; CAULKERS; CLEANERS; POINTERS; & STONEMASONS.....	\$ 34.85	16.94
SANDBLASTERS.....	\$ 35.10	16.94
SEWER BRICKLAYERS & STACK BUILDERS.....	\$ 35.35	16.94
SWING SCAFFOLDS.....	\$ 35.35	16.94

BROH0006-005 06/01/2019

CARROLL, COLUMBIANA (Knox, Butler, West & Hanover Townships), STARK & TUSCARAWAS

	Rates	Fringes
Bricklayer, Stonemason.....	\$ 29.34	16.11

BROH0007-002 06/01/2019

LAWRENCE

	Rates	Fringes
Bricklayer, Stonemason.....	\$ 29.34	16.11

BROH0007-005 06/01/2019

PORTAGE & SUMMIT

	Rates	Fringes
BRICKLAYER.....	\$ 29.34	16.11

BROH0007-010 06/01/2019

PORTAGE & SUMMIT

	Rates	Fringes
MASON - STONE.....	\$ 29.34	16.11

BROH0008-001 06/01/2019		

COLUMBIANA (Salem, Perry, Fairfield, Center, Elk Run, Middleton, & Unity Townships and the city of New Waterford), MAHONING & TRUMBULL

	Rates	Fringes
BRICKLAYER.....	\$ 29.34	16.11

BROH0009-002 06/01/2019		

BELMONT & MONROE COUNTIES and the Townships of Warren & Mt. Pleasant and the Village of Dillonvale in JEFFERSON COUNTY

	Rates	Fringes
Bricklayer, Stonemason.....	\$ 29.34	16.11
Refractory.....	\$ 31.45	19.01

BROH0010-002 06/01/2019		

COLUMBIANA (St. Clair, Madison, Wayne, Franklin, Washington, Yellow Creek & Liverpool Townships) & JEFFERSON (Brush Creek & Saline Townships)

	Rates	Fringes
Bricklayer, Stonemason.....	\$ 29.34	16.11

BROH0014-002 06/01/2019		

HARRISON & JEFFERSON (Except Mt. Pleasant, Warren, Brush Creek, Saline & Salineville Townships & the Village of Dillonvale)

	Rates	Fringes
Bricklayer, Stonemason.....	\$ 29.34	16.11

BROH0016-002 06/01/2019		

ASHTABULA, GEAUGA, and LAKE COUNTIES

	Rates	Fringes
Bricklayer, Stonemason.....	\$ 29.34	16.11

BROH0018-002 06/01/2019		

BROWN, BUTLER, CLERMONT, HAMILTON, PREBLE (Gasper, Dixon, Israel, Lanier, Somers & Gratis Townships) & WARREN COUNTIES:

	Rates	Fringes
Bricklayer, Stonemason.....	\$ 29.34	16.11

BROH0022-004 06/01/2019

CHAMPAIGN, CLARK, CLINTON, DARKE, GREENE, HIGHLAND, LOGAN,
MIAMI, MONTGOMERY, PREBLE (Jackson, Monroe, Harrison, Twin,
Jefferson & Washington Townships) and SHELBY COUNTIES

	Rates	Fringes
Bricklayer, Stonemason.....	\$ 29.34	16.11

BROH0032-001 06/01/2019

GALLIA & MEIGS

	Rates	Fringes
Bricklayer, Stonemason.....	\$ 29.34	16.11

BROH0035-002 06/01/2019

ALLEN, AUGLAIZE, MERCER and VAN WERT COUNTIES

	Rates	Fringes
Bricklayer, Stonemason.....	\$ 29.34	16.11

BROH0039-002 06/01/2019

ADAMS & SCIOTO

	Rates	Fringes
Bricklayer, Stonemason.....	\$ 29.34	16.11

BROH0040-003 06/01/2019

ASHLAND, CRAWFORD, HARDIN, HOLMES, MARION, MORROW, RICHLAND,
WAYNE and WYANDOT (Except Crawford, Ridge, Richland & Tymochtee
Townships) COUNTIES

	Rates	Fringes
Bricklayer, Stonemason.....	\$ 29.34	16.11

FOOTNOTE: Layout Man and Sawman rate: \$1.00 per hour above
journeyman rate.

Free standing stack work ground level to top of stack;
Sandblasting and laying of carbon masonry material in swing
stage and/or scaffold; Ramming and spading of plastics and
gunniting: \$1.50 per hour above journeyman rate.

""Hot"" work: \$2.50 above journeyman rate.

BROH0044-002 06/01/2019

Rates Fringes

Bricklayer, Stonemason
 COSHOCTON, FAIRFIELD,
 GUERNSEY, HOCKING, KNOX,
 KICKING, MORGAN,
 MUSKINGUM, NOBLE (Beaver,
 Buffalo, Seneca & Wayne
 Townships) & PERRY
 COUNTIES:.....\$ 29.34 16.11

BROH0045-002 06/01/2017

FAYETTE, JACKSON, PIKE, ROSS and VINTON COUNTIES

	Rates	Fringes
Bricklayer, Stonemason.....	\$ 28.65	14.55

BROH0046-002 06/01/2019

ERIE, HANCOCK, HURON, OTTAWA, SANDUSKY, SENECA, WOOD (Perry & Bloom Townships) and WYANDOT (Tymochtee, Crawford, Ridge & Richland Townships) COUNTIES & the Islands of Lake Erie north of Sandusky

	Rates	Fringes
Bricklayer, Stonemason.....	\$ 29.34	16.11

FOOTNOTE: Layout Man and Sawman rate: \$1.00 per hour above journeyman rate.
 Free standing stack work ground level to top of stack;
 Sandblasting and laying of carbon masonry material in swing stage and/or scaffold; Ramming and spading of plastics and gunniting: \$1.50 per hour above journeyman rate.
 ""Hot"" work: \$2.50 above journeyman rate.

BROH0052-001 06/01/2019

ATHENS COUNTY

	Rates	Fringes
Bricklayer, Stonemason.....	\$ 29.34	16.11

BROH0052-003 06/01/2019

NOBLE (Brookfield, Noble, Center, Sharon, Olive, Enoch, Stock, Jackson, Jefferson & Elk Townships) and WASHINGTON COUNTIES

	Rates	Fringes
Bricklayer, Stonemason.....	\$ 29.34	16.11

BROH0055-003 06/01/2017

DELAWARE, FRANKLIN, MADISON, PICKAWAY and UNION COUNTIES

Rates	Fringes
-------	---------

Bricklayer, Stonemason.....	\$ 28.65	14.55

CARP0003-004 05/01/2017		

MAHONING & TRUMBULL

	Rates	Fringes
CARPENTER.....	\$ 26.20	17.42

CARP0069-003 05/01/2017		

CARROLL, STARK, TUSCARAWAS & WAYNE

	Rates	Fringes
CARPENTER.....	\$ 25.98	15.98

CARP0069-006 05/01/2017		

COSHOCTON, HOLMES, KNOX & MORROW

	Rates	Fringes
CARPENTER.....	\$ 24.04	15.29

CARP0171-002 05/01/2019		

BELMONT, COLUMBIANA, HARRISON, JEFFERSON & MONROE

	Rates	Fringes
CARPENTER.....	\$ 27.37	20.02

CARP0200-002 05/01/2017		

ADAMS, ATHENS, DELAWARE, FAIRFIELD, FAYETTE, FRANKLIN, GALLIA,
GUERNSEY, HIGHLAND, HOCKING, JACKSON, LAWRENCE, LICKING,
MADISON, MARION, MEIGS, MORGAN, MUSKINGUM, NOBLE, PERRY,
PICKAWAY, PIKE, ROSS, SCIOTO, UNION, VINTON and WASHINGTON
COUNTIES

	Rates	Fringes
CARPENTER.....	\$ 29.07	16.22
Diver.....	\$ 39.41	10.40
PILEDRIVERMAN.....	\$ 29.07	16.22

CARP0248-005 07/01/2008		

LUCAS & WOOD

	Rates	Fringes
CARPENTER.....	\$ 27.27	14.58

CARP0248-008 07/01/2008		

	Rates	Fringes
--	-------	---------

CARPENTER
 DEFIANCE, FULTON, HANCOCK,
 HENRY, PAULDING & WILLIAMS
 COUNTIES.....\$ 23.71 13.28

CARP0254-002 05/01/2017

ASHTABULA, CUYAHOGA, GEAUGA & LAKE

	Rates	Fringes
CARPENTER.....	\$ 32.40	16.97

CARP0372-002 05/01/2016

ALLEN, AUGLAIZE, HARDIN, MERCER, PUTNAM & VAN WERT

	Rates	Fringes
CARPENTER.....	\$ 24.54	18.21

CARP0639-003 05/01/2017

MEDINA, PORTAGE & SUMMIT

	Rates	Fringes
CARPENTER.....	\$ 30.42	16.99

CARP0735-002 05/01/2019

ASHLAND, ERIE, HURON, LORAIN & RICHLAND

	Rates	Fringes
CARPENTER.....	\$ 26.30	17.91

CARP1311-001 05/01/2017

BROWN, BUTLER, CHAMPAIGN, CLARK, CLERMONT, CLINTON, DARKE,
GREENE, HAMILTON, LOGAN, MIAMI, MONTGOMERY, PREBLE, SHELBY &
WARREN

	Rates	Fringes
Carpenter & Piledrivermen.....	\$ 29.34	15.95
Diver.....	\$ 40.58	9.69

CARP1393-002 07/01/2008

CRAWFORD, DEFIANCE, FULTON, HANCOCK, HENRY, LUCAS, OTTAWA,
PAULDING, SANDUSKY, SENECA, WILLIAMS & WOOD

	Rates	Fringes
Piledrivermen & Diver's Tender...	\$ 27.30	16.05

DIVERS - \$250.00 per day

CARP1393-003 07/01/2008

ALLEN, AUGLAIZE, HARDIN, MERCER, PUTNAM, VAN WERT & WYANDOT

	Rates	Fringes
Piledrivermen & Diver's Tender...	\$ 25.15	15.92

DIVERS - \$250.00 per day

CARP1871-006 05/01/2017

BELMONT, HARRISON, & MONROE

	Rates	Fringes
Diver, Wet.....	\$ 48.11	17.33
Piledrivermen; Diver, Dry.....	\$ 32.07	17.33

CARP1871-008 05/01/2017

ASHLAND, ASHTABULA, CUYAHOGA, ERIE, GEAUGA, HURON, LAKE,
LORAIN, MEDINA, PORTAGE, RICHLAND & SUMMIT

	Rates	Fringes
Diver, Wet.....	\$ 45.80	18.84
Piledrivermen; Diver, Dry.....	\$ 30.53	18.84

CARP1871-014 05/01/2017

CARROLL, STARK, TUSCARAWAS & WAYNE

	Rates	Fringes
Diver, Wet.....	\$ 38.34	16.95
Piledrivermen; Diver, Dry.....	\$ 25.56	16.95

CARP1871-015 05/01/2017

COSHOCTON, HOLMES, KNOX & MORROW

	Rates	Fringes
Diver, Wet.....	\$ 37.34	16.07
Piledrivermen; Diver, Dry.....	\$ 24.89	16.07

CARP1871-017 05/01/2017

MAHONING & TRUMBULL

	Rates	Fringes
Diver, Wet.....	\$ 40.65	17.62
Piledrivermen; Diver, Dry.....	\$ 27.10	17.62

CARP2235-012 01/01/2014

COLUMBIANA & JEFFERSON

Rates Fringes

PILED RIVERMAN.....\$ 31.74 16.41

CARP2239-001 07/01/2008

CRAWFORD, OTTAWA, SANDUSKY, SENECA & WYANDOT

Rates Fringes

CARPENTER.....\$ 23.71 13.28

ELEC0008-002 05/25/2020

DEFIANCE, FULTON, HANCOCK, HENRY, LUCAS, OTTAWA, PAULDING,
PUTNAM, SANDUSKY, SENECA, WILLIAMS & WOOD

Rates Fringes

CABLE SPLICER.....\$ 38.98 18.96
ELECTRICIAN.....\$ 41.81 4.5%+20.73

ELEC0032-003 11/29/2020

ALLEN, AUGLAIZE, HARDIN, LOGAN, MERCER, SHELBY, VAN WERT &
WYANDOT (Crawford, Jackson, Marseilles, Mifflin, Ridgeland,
Ridge & Salem Townships)

Rates Fringes

ELECTRICIAN.....\$ 32.12 20.29

ELEC0038-002 04/27/2020

CUYAHOGA, GEAUGA (Bainbridge, Chester & Russell Townships) &
LORAIN (Columbia Township)

Rates Fringes

ELECTRICIAN
Excluding Sound &
Communications Work.....\$ 39.88 21.22

FOOTNOTES;

- a. 6 Paid Holidays: New Year's Day; Memorial Day; July 4th;
Labor Day; Thanksgiving Day; & Christmas Day
- b. 1 week's paid vacation for 1 year's service; 2 weeks' paid
vacation for 2 or more years' service

ELEC0038-008 04/29/2019

CUYAHOGA, GEAUGA (Bainbridge, Chester & Russell Townships) &
LORAIN (Columbia Township)

Rates Fringes

Sound & Communication
Technician
Communications Technician...\$ 27.55 11.98

Installer Technician.....\$ 26.30 11.94

FOOTNOTES;

- a. 6 Paid Holidays: New Year's Day; Memorial Day; July 4th; Labor Day; Thanksgiving Day; & Christmas Day
- b. 1 week's paid vacation for 1 year's service; 2 weeks' paid vacation for 2 or more years' service

ELEC0064-003 11/30/2020

COLUMBIANA (Butler, Fairfield, Perry, Salem & Unity Townships)
MAHONING (Austintown, Beaver, Berlin, Boardman, Canfield, Ellsworth, Coitsville, Goshen, Green, Jackson, Poland, Springfield & Youngstown Townships), & TRUMBULL (Hubbard & Liberty Townships)

	Rates	Fringes
ELECTRICIAN.....	\$ 35.67	16.37

ELEC0071-001 01/01/2019

ASHLAND, CHAMPAIGN, CLARK, COSHOCTON, CRAWFORD, DELAWARE, FAIRFIELD, FAYETTE, FRANKLIN, GUERNSEY, HIGHLAND, HOCKING, JACKSON (Coal, Jackson, Liberty, Milton, Washington & Wellston Townships), KNOX, LICKING, MADISON, MARION, MONROE, MORGAN, MORROW, MUSKINGUM, NOBLE, PERRY, PICKAWAY, PIKE (Beaver, Benton, Jackson, Mifflin, Pebble, Peepee, Perry & Seal Townships), RICHLAND, ROSS, TUSCARAWAS (Auburn, Bucks, Clay, Jefferson, Oxford, Perry, Salem, Rush, Washington & York Townships), UNION, VINTON (Clinton, Eagle, Elk, Harrison, Jackson, Richland & Swan Townships), and WASHINGTON COUNTIES

	Rates	Fringes
Line Construction		
Equipment Operators.....	\$ 33.62	13.40
Groundmen.....	\$ 24.17	11.32
Linemen & Cable Splicers....	\$ 38.27	14.42

ELEC0071-004 01/01/2019

AUGLAIZE, CLINTON, DARKE, GREENE, LOGAN, MERCER, MIAMI, MONTGOMERY, PREBLE, and SHELBY COUNTIES

	Rates	Fringes
Line Construction		
Equipment Operator.....	\$ 33.62	13.40
Groundman.....	\$ 24.17	11.32
Lineman & Cable Splicers....	\$ 38.27	14.42

ELEC0071-005 12/31/2018

ASHTABULA, CUYAHOGA, GEAUGA, LAKE & LORAIN

	Rates	Fringes
--	-------	---------

LINE CONSTRUCTION: Equipment
Operator

DOT/Traffic Signal & Highway Lighting Projects...\$ 32.44	14.10
Municipal Power/Transit Projects.....\$ 40.10	16.42

LINE CONSTRUCTION: Groundman

DOT/Traffic Signal & Highway Lighting Projects...\$ 25.06	12.26
Municipal Power/Transit Projects.....\$ 31.19	14.11

LINE CONSTRUCTION:

Linemen/Cable Splicer

DOT/Traffic Signal & Highway Lighting Projects...\$ 36.13	15.03
Municipal Power/Transit Projects.....\$ 44.56	17.58

ELEC0071-008 01/01/2019

COLUMBIANA, MAHONING, and TRUMBULL COUNTIES

Rates Fringes

Line Construction

Equipment Operator.....\$ 33.62	13.40
Groundman.....\$ 24.17	11.32
Lineman & Cable Splicers...\$ 38.27	14.42

ELEC0071-010 01/01/2019

BELMONT, CARROLL, HARRISON, HOLMES, JEFFERSON, MEDINA, PORTAGE,
STARK, SUMMIT, and WAYNE COUNTIES

Rates Fringes

Line Construction

Equipment Operator.....\$ 33.62	13.40
Groundman.....\$ 24.17	11.32
Lineman & Cable Splicers...\$ 38.27	14.42

ELEC0071-013 01/01/2019

BROWN, BUTLER, CLERMONT, HAMILTON, and WARREN COUNTIES

Rates Fringes

Line Construction

Equipment Operator.....\$ 33.62	13.40
Groundman.....\$ 24.17	11.32
Lineman & Cable Splicers...\$ 38.27	14.42

ELEC0071-014 01/01/2019

ADAMS, ATHENS, GALLIA, JACKSON (Bloomfield, Franklin, Hamilton,
Lick, Jefferson, Scioto & Madison Townships), LAWRENCE, MEIGS,
PIKE (Camp Creek, Marion, Newton, Scioto, Sunfish & Union
Townships), SCIOTO & VINTON (Brown, Knox, Madison, Vinton &
Wilkesville Townships)

	Rates	Fringes
Line Construction		
Equipment Operator.....	\$ 33.62	13.40
Groundman.....	\$ 24.17	11.32
Lineman & Cable Splicers....	\$ 38.27	14.42

ELEC0082-002 12/02/2019

CLINTON, DARKE, GREENE, MIAMI, MONTGOMERY, PREBLE & WARREN
(Wayne, Clear Creek & Franklin Townships)

	Rates	Fringes
ELECTRICIAN.....	\$ 31.15	19.96

ELEC0082-006 11/26/2018

CLINTON, DARKE, GREENE, MIAMI, MONTGOMERY, PREBLE & WARREN
(Wayne, Clear Creek & Franklin Townships)

	Rates	Fringes
Sound & Communication Technician		
Cable Puller.....	\$ 12.18	3.85
Installer/Technician.....	\$ 24.35	11.29

ELEC0129-003 02/24/2020

LORAIN (Except Columbia Township) & MEDINA (Litchfield & Liverpool Townships)

	Rates	Fringes
ELECTRICIAN.....	\$ 35.35	17.68

ELEC0129-004 02/24/2020

ERIE & HURON (Lyme, Ridgefield, Norwalk, Townsend, Wakeman,
Sherman, Peru, Bronson, Hartland, Clarksfield, Norwich,
Greenfield, Fairfield, Fitchville & New London Townships)

	Rates	Fringes
ELECTRICIAN.....	\$ 35.35	17.68

ELEC0141-003 09/01/2019

BELMONT COUNTY

	Rates	Fringes
CABLE SPLICER.....	\$ 30.63	25.87
ELECTRICIAN.....	\$ 30.38	25.87

ELEC0212-003 11/26/2018

BROWN, CLERMONT & HAMILTON

	Rates	Fringes
Sound & Communication Technician.....	\$ 24.35	10.99

ELEC0212-005 06/03/2020		

BROWN, CLERMONT, and HAMILTON COUNTIES

	Rates	Fringes
ELECTRICIAN.....	\$ 31.30	19.07

ELEC0245-001 01/01/2020		

ALLEN, HARDIN, VAN WERT & WYANDOT (Crawford, Jackson, Marseilles, Mifflin, Richland, Ridge & Salem Townships)

	Rates	Fringes
Line Construction		
Equipment Operator.....	\$ 32.37	25.9%+6.75
Groundman Truck Driver.....	\$ 17.70	25.9%+6.75
Lineman.....	\$ 40.46	25.9%+6.75

FOOTNOTE: a. Half day's Paid Holiday: The last 4 hours of the workday prior to Christmas or New Year's Day

ELEC0245-003 01/01/2020

DEFIANCE, FULTON, HANCOCK, HENRY, HURON, LUCAS, OTTAWA, PAULDING, PUTNAM, SANDUSKY, SENECA, WILLIAMS, and WOOD COUNTIES

	Rates	Fringes
Line Construction		
Cable Splicer.....	\$ 46.53	25.9%+6.75
Groundman/Truck Driver.....	\$ 17.70	25.9%+6.75
Heli-arc Welding.....	\$ 40.76	25.9%+6.75
Lineman.....	\$ 40.46	25.9%+6.75
Operator - Class 1.....	\$ 32.37	25.9%+6.75
Operator - Class 2.....	\$ 28.32	25.9%+6.75
Traffic Signal & Lighting Technician.....	\$ 36.41	25.9%+6.75

FOOTNOTE: a. 6 Observed Holidays: New Year's Day; Memorial Day; Independence Day; Labor Day; Thanksgiving Day; & Christmas Day. Employees who work on a holiday shall be paid at a rate of double their applicable classified straight-time rates for the work performed on such holiday.

ELEC0245-004 01/01/2020

ERIE COUNTY

Rates Fringes

Line Construction

Cable Splicer.....	\$ 46.53	25.9%+6.75
Groundman/Truck Driver.....	\$ 17.70	25.9%+6.75
Lineman.....	\$ 40.46	25.9%+6.75
Operator - Class 1.....	\$ 32.37	25.9%+6.75
Operator - Class 2.....	\$ 28.32	25.9%+6.75

FOOTNOTE: a. 6 Observed Holidays: New Year's Day; Memorial Day; Independence Day; Labor Day; Thanksgiving Day; & Christmas Day. Employees who work on a holiday shall be paid at a rate of double their applicable classified straight-time rates for the work performed on such holiday.

ELEC0246-001 10/29/2018

	Rates	Fringes
ELECTRICIAN.....	\$ 38.00	84%+a

FOOTNOTE: a. 1 1/2 Paid Holidays: The last scheduled workday prior to Christmas & 4 hours on Good Friday.

ELEC0306-005 05/28/2018

MEDINA (Brunswick, Chatham, Granger, Guilford, Harrisville, Hinckley, Homer, Lafayette, Medina, Montville, Sharon, Spencer, Wadsworth, Westfield & York Townships), PORTAGE (Atwater, Aurora, Brimfield, Deerfield, Franklin, Mantua, Randolph, Ravenna, Rootstown, Shalersville, Streetsboro & Suffield Townships), SUMMIT & WAYNE (Baughman, Canaan, Chester, Chippewa, Congress, Green, Milton, & Wayne Townships)

	Rates	Fringes
CABLE SPLICER.....	\$ 36.87	16.56
ELECTRICIAN.....	\$ 34.54	5%+18.06

ELEC0317-002 06/01/2020

GALLIA & LAWRENCE

	Rates	Fringes
CABLE SPLICER.....	\$ 32.68	18.13
ELECTRICIAN.....	\$ 35.10	26.22

ELEC0540-005 01/01/2020

CARROLL (Northern half, including Fox, Harrison, Rose & Washington Townships), COLUMBIANA (Knox Township), HOLMES, MAHONING (Smith Township), STARK, TUSCARAWAS (North of Auburn, Clay, Rush & York Townships), and WAYNE (South of Baughman, Chester, Green & Wayne Townships) COUNTIES

	Rates	Fringes
ELECTRICIAN.....	\$ 33.71	24.22

ELEC0573-003 06/01/2020

ASHTABULA (Colebrook, Wayne, Williamsfield, Orwell & Windsor Townships), GEAUGA (Auburn, Middlefield, Parkman & Troy Townships), MAHONING (Milton Township), PORTAGE (Charlestown, Edinburg, Freedom, Hiram, Nelson, Palmyra, Paris & Windham Townships), and TRUMBULL (Except Liberty & Hubbard Townships)

	Rates	Fringes
ELECTRICIAN.....	\$ 34.11	19.46

ELEC0575-001 11/30/2020

ADAMS, FAYETTE, HIGHLAND, HOCKING, JACKSON (Bloomfield, Franklin, Hamilton, Jefferson, Lick, Madison, Scioto, Coal, Jackson, Liberty, Milton & Washington Townships), PICKAWAY (Deer Creek, Perry, Pickaway, Salt Creek & Wayne Townships), PIKE (Beaver, Benton, Jackson, Mifflin, Pebble, PeePee, Perry, Seal, Camp Creek, Newton, Scioto, Sunfish, Union & Marion Townships), ROSS, SCIOTO & VINTON (Clinton, Eagle, Elk, Harrison, Jackson, Richland & Swan Townships)

	Rates	Fringes
ELECTRICIAN.....	\$ 33.75	19.22

ELEC0648-001 09/02/2019

BUTLER and WARREN COUNTIES (Deerfield, Hamilton, Harlan, Massie, Salem, Turtle Creek, Union & Washington Townships)

	Rates	Fringes
CABLE SPLICER.....	\$ 30.50	18.23
ELECTRICIAN.....	\$ 30.00	19.85

ELEC0673-004 02/01/2020

ASHTABULA (Excluding Orwell, Colebrook, Williamsfield, Wayne & Windsor Townships), GEAUGA (Burton, Chardon, Claridon, Hamdben, Huntsburg, Montville, Munson, Newbury & Thompson Townships) and LAKE COUNTIES

	Rates	Fringes
CABLE SPLICER.....	\$ 33.81	21.47
ELECTRICIAN.....	\$ 33.56	21.47

ELEC0683-002 06/01/2020

CHAMPAIGN, CLARK, DELAWARE, FAIRFIELD, FRANKLIN, MADISON, PICKAWAY (Circleville, Darby, Harrison, Jackson, Madison, Monroe, Muhlenberg, Scioto, Walnut & Washington Townships), and UNION COUNTIES

	Rates	Fringes
CABLE SPLICER.....	\$ 35.50	21.06
ELECTRICIAN.....	\$ 34.50	21.06

ELEC0688-003 06/01/2020

ASHLAND, CRAWFORD, HURON (Richmond, New Haven, Ripley & Greenwich Townships), KNOX (Liberty, Clinton, Union, Howard, Monroe, Middleberry, Morris, Wayne, Berlin, Pike, Brown & Jefferson Townships), MARION, MORROW, RICHLAND and WYANDOT (Sycamore, Crane, Eden, Pitt, Antrim & Tymochtee Townships) COUNTIES

	Rates	Fringes
ELECTRICIAN.....	\$ 30.00	19.66

ELEC0972-002 06/01/2020

ATHENS, MEIGS, MONROE, MORGAN, NOBLE, VINTON (Brown, Knox, Madison, Vinton & Wilkesville Townships), and WASHINGTON COUNTIES

	Rates	Fringes
CABLE SPLICER.....	\$ 37.35	27.81
ELECTRICIAN.....	\$ 33.95	27.71

ELEC1105-001 05/28/2018

COSHOCTON, GUERNSEY, KNOX (Jackson, Clay, Morgan, Miller, Milford, Hilliar, Butler, Harrison, Pleasant & College Townships), LICKING, MUSKINGUM, PERRY, and TUSCARAWAS (Auburn, York, Clay, Jefferson, Rush, Oxford, Washington, Salem, Perry & Bucks Townships) COUNTIES

	Rates	Fringes
ELECTRICIAN.....	\$ 30.95	17.96

ENGI0018-003 05/01/2019

ASHTABULA, CUYAHOGA, ERIE, GAUGA, LAKE, LORAIN, MEDINA, PORTAGE, and SUMMIT COUNTIES

	Rates	Fringes
POWER EQUIPMENT OPERATOR		
GROUP 1.....	\$ 38.63	15.20
GROUP 2.....	\$ 38.53	15.20
GROUP 3.....	\$ 37.49	15.20
GROUP 4.....	\$ 36.27	15.20
GROUP 5.....	\$ 30.98	15.20
GROUP 6.....	\$ 38.88	15.20
GROUP 7.....	\$ 39.13	15.20

OPERATING ENGINEER CLASSIFICATIONS

GROUP 1 - Air Compressor on Steel Erection; Barrier Moving Machine; Boiler Operator on Compressor or Generator when mounted on a Rig; Cableway; Combination Concrete Mixer & Tower; Concrete Plant (over 4 yd. Capacity); Concrete Pump; Crane (All Types, Including Boom Truck, Cherry Picker); Crane-Compact, Track or Rubber over 4,000 lbs. capacity; Cranes-Self Erecting, Stationary, Track or Truck (All Configurations); Derrick; Dragline; Dredge (Dipper, Clam or Suction); Elevating Grader or Euclid Loader; Floating Equipment (All Types); Gradall; Helicopter Crew (Operator-Hoist or Winch); Hoe (all types); Hoisting Engine on Shaft or Tunnel Work; Hydraulic Gantry (Lifting System); Industrial-Type Tractor; Jet Engine Dryer (D8 or D9) Diesel Tractor; Locomotive (Standard Gauge); Maintenance Operator Class A; Mixer, Paving (Single or Double Drum); Mucking Machine; Multiple Scraper; Piledriving Machine (All Types); Power Shovel; Prentice Loader; Quad 9 (Double Pusher); Rail Tamper (with auto lifting & aligning device); Refrigerating Machine (Freezer Operation); Rotary Drill, on Caisson work; Rough Terrain Fork Lift with Winch/Hoist; Side-Boom; Slip-Form Paver; Tower Derrick; Tree Shredder; Trench Machine (Over 24" wide); Truck Mounted Concrete Pump; Tug Boat; Tunnel Machine and/or Mining Machine; Wheel Excavator; and Asphalt Plant Engineer (Cleveland District Only).

GROUP 2 - Asphalt Paver; Automatic Subgrader Machine, Self-Propelled (CMI Type); Bobcat Type and/or Skid Steer Loader with Hoe Attachment Greater than 7,000 lbs.; Boring Machine More than 48"; Bulldozer; Endloader; Horizontal Directional Drill (Over 50,000 ft lbs thrust); Hydro Milling Machine; Kolman-type Loader (production type-Dirt); Lead Greaseman; Lighting & Traffic Signal Installation Equipment (includes all groups or classifications); Material Transfer Equipment (Shuttle Buggy) Asphalt; Pettibone-Rail Equipment; Power Grader; Power Scraper; Push Cat; Rotomill (all), Grinders & Planers of All types; Trench Machine (24" wide & under); Vermeer type Concrete Saw; and Maintenance Operators (Portage and Summit Counties Only).

GROUP 3 - A-Frame; Air Compressor on Tunnel Work (low pressure); Asphalt Plant Engineer (Portage and Summit Counties Only); Bobcat-type and/or Skid Steer Loader with or without Attachments; Highway Drills (all types); Locomotive (narrow gauge); Material Hoist/Elevator; Mixer, Concrete (more than one bag capacity); Mixer, one bag capacity (Side Loader); Power Boiler (Over 15 lbs. Pressure) Pump Operator installing & operating Well Points; Pump (4" & over discharge); Roller, Asphalt; Rotovator (lime soil stabilizer); Switch & Tie Tampers (without lifting & aligning device); Utility Operator (Small equipment); Welding Machines; and Railroad Tie Inserter/Remover; Articulating/straight bed end dumps if assigned (minus \$4.00 per hour).

GROUP 4 - Backfiller; Ballast Re-locator; Bars, Joint & Mesh Installing Machine; Batch Plant; Boring Machine Operator (48" or less); Bull Floats; Burlap & Curing Machine; Concrete Plant (capacity 4 yd. & under); Concrete Saw (Multiple); Conveyor (Highway); Crusher; Deckhand;

Farm-type Tractor with attachments (highway); Finishing Machine; Fireperson, Floating Equipment (all types); Forklift; Form Trencher; Hydro Hammer expect masonry; Hydro Seeder; Pavement Breaker; Plant Mixer; Post Driver; Post Hole Digger (Power Auger); Power Brush Burner; Power Form Handling Equipment; Road Widening Trencher; Roller (Brick, Grade & Macadam); Self-Propelled Power Spreader; Self-Propelled Power Subgrader; Steam Fireperson; Tractor (Pulling Sheepfoot, Roller or Grader); and Vibratory Compactor with Integral Power.

GROUP 5 - Compressor (Portable, Sewer, Heavy & Highway); Drum Fireperson (Asphalt Plant); Generator; Masonry Fork Lift; Inboard-Outboard Motor Boat Launch; Oil Heater (asphalt plant); Oiler/Helper; Power Driven Heater; Power Sweeper & Scrubber; Pump (under 4" discharge); Signalperson; Tire Repairperson; VAC/ALLS; Cranes - Compact, track or rubber under 4,000 pound capacity; fueling and greasing; and Chainmen.

GROUP 6 - Master Mechanic & Boom from 150 to 180.

GROUP 7 - Boom from 180 and over.

ENGI0018-004 05/01/2019

ADAMS, ALLEN, ASHLAND, ATHENS, AUGLAIZE, BELMONT, BROWN, BUTLER, CARROLL, CHAMPAIGN, CLARK, CLERMONT, CLINTON, COSHOCTON, CRAWFORD, DARKE, DEFIANCE, DELAWARE, FAIRFIELD, FAYETTE, FRANKLIN, FULTON, GALLIA, GREENE, GUERNSEY, HAMILTON, HANCOCK, HARDIN, HARRISON, HENRY, HIGHLAND, HOCKING, HOLMES, HURON, JACKSON, JEFFERSON, KNOX, LAWRENCE, LICKING, LOGAN, LUCAS, MADISON, MARION, MEIGS, MERCER, MIAMI, MONROE, MONTGOMERY, MORGAN, MORROW, MUSKINGUM, NOBLE, OTTAWA, PAULDING, PERRY, PICKAWAY, PIKE, PREBLE, PUTNAM, RICHLAND, ROSS, SANDUSKY, SCIOTO, SENECA, SHELBY, STARK, TUSCARAWAS, UNION, VAN WERT, VINTON, WARREN, WASHINGTON, WAYNE, WILLIAMS, WOOD, and YANDOT COUNTIES

	Rates	Fringes
POWER EQUIPMENT OPERATOR		
GROUP 1.....	\$ 37.14	15.20
GROUP 2.....	\$ 37.02	15.20
GROUP 3.....	\$ 35.98	15.20
GROUP 4.....	\$ 34.80	15.20
GROUP 5.....	\$ 29.34	15.20
GROUP 6.....	\$ 37.39	15.20
GROUP 7.....	\$ 37.64	15.20

OPERATING ENGINEER CLASSIFICATIONS

GROUP 1 - Air Compressor on Steel Erection; Barrier Moving Machine; Boiler Operator on Compressor or Generator when mounted on a Rig; Cableway; Combination Concrete Mixer & Tower; Concrete Plant (over 4 yd. Capacity); Concrete Pump; Crane (All Types, Including Boom Truck, Cherry Picker); Crane-Compact, Track or Rubber over 4,000 lbs. capacity; Cranes-Self Erecting, Stationary, Track or Truck (All Configurations); Derrick; Dragline; Dredge (Dipper, Clam or

Suction); Elevating Grader or Euclid Loader; Floating Equipment (All Types); Gradall; Helicopter Crew (Operator-Hoist or Winch); Hoe (all types); Hoisting Engine on Shaft or Tunnel Work; Hydraulic Gantry (Lifting System); Industrial-Type Tractor; Jet Engine Dryer (D8 or D9) Diesel Tractor; Locomotive (Standard Gauge); Maintenance Operator Class A; Mixer, Paving (Single or Double Drum); Mucking Machine; Multiple Scraper; Piledriving Machine (All Types); Power Shovel; Prentice Loader; Quad 9 (Double Pusher); Rail Tamper (with auto lifting & aligning device); Refrigerating Machine (Freezer Operation); Rotary Drill, on Caisson work; Rough Terrain Fork Lift with Winch/Hoist; Side-Boom; Slip-Form Paver; Tower Derrick; Tree Shredder; Trench Machine (Over 24" wide); Truck Mounted Concrete Pump; Tug Boat; Tunnel Machine and/or Mining Machine; and Wheel Excavator.

GROUP 2 - Asphalt Paver; Automatic Subgrader Machine, Self-Propelled (CMI Type); Bobcat Type and/or Skid Steer Loader with Hoe Attachment Greater than 7,000 lbs.; Boring Machine More than 48"; Bulldozer; Endloader; Hydro Milling Machine; Horizontal Directional Drill (over 50,000 ft. lbs. thrust); Kolman-type Loader (production type-Dirt); Lead Greaseman; Lighting & Traffic Signal Installation Equipment (includes all groups or classifications); Material Transfer Equipment (Shuttle Buggy) Asphalt; Pettibone-Rail Equipment; Power Grader; Power Scraper; Push Cat; Rotomill (all), Grinders & Planers of All types; Trench Machine (24" wide & under); and Vermeer type Concrete Saw.

GROUP 3 - A-Frame; Air Compressor on Tunnel Work (low pressure); Asphalt Plant Engineer; Bobcat-type and/or Skid Steer Loader with or without Attachments; Highway Drills (all types); Locomotive (narrow gauge); Material Hoist/Elevator; Mixer, Concrete (more than one bag capacity); Mixer, one bag capacity (Side Loader); Power Boiler (Over 15 lbs. Pressure) Pump Operator installing & operating Well Points; Pump (4" & over discharge); Railroad Tie Inserter/Remover; Roller, Asphalt; Rotovator (lime soil stabilizer); Switch & Tie Tampers (without lifting & aligning device); Utility Operator (Small equipment); and Welding Machines; Articulating/straight bed end dumps if assigned (minus \$4.00 per hour).

GROUP 4 - Backfiller; Ballast Re-locator; Bars, Joint & Mesh Installing Machine; Batch Plant; Boring Machine Operator (48" or less); Bull Floats; Burlap & Curing Machine; Concrete Plant (capacity 4 yd. & under); Concrete Saw (Multiple); Conveyor (Highway); Crusher; Deckhand; Farm-type Tractor with attachments (highway); Finishing Machine; Fireperson, Floating Equipment (all types); Fork Lift; Form Trencher; Hydro Hammer expect masonry; Hydro Seeder; Pavement Breaker; Plant Mixer; Post Driver; Post Hole Digger (Power Auger); Power Brush Burner; Power Form Handling Equipment; Road Widening Trencher; Roller (Brick, Grade & Macadam); Self-Propelled Power Spreader; Self-Propelled Power Subgrader; Steam Fireperson; Tractor (Pulling Sheepfoot, Roller or Grader); and Vibratory Compactor with Integral Power.

GROUP 5 - Compressor (Portable, Sewer, Heavy & Highway); Drum Fireperson (Asphalt Plant); Generator; Masonary Forklift;

Inboard-Outboard Motor Boat Launch; Oil Heater (asphalt plant); Oiler/Helper; Power Driven Heater; Power Sweeper & Scrubber; Pump (under 4" discharge); Signalperson; Tire Repairperson; VAC/ALLS; Cranes - Compact, track or rubber under 4,000 pound capacity; fueling and greasing; and Chainmen.

GROUP 6 - Master Mechanic & Boom from 150 to 180.

GROUP 7 - Boom from 180 and over.

ENGI0066-023 06/01/2017

COLUMBIANA, MAHONING & TRUMBULL COUNTIES

	Rates	Fringes
POWER EQUIPMENT OPERATOR		
ASBESTOS; HAZARDOUS/TOXIC WASTE PROJECTS		
GROUP 1 - A & B.....	\$ 39.23	19.66
ASBESTOS; HAZARDOUS/TOXIC WASTE PROJECTS		
GROUP 2 - A & B.....	\$ 38.90	19.66
ASBESTOS; HAZARDOUS/TOXIC WASTE PROJECTS		
GROUP 3 - A & B.....	\$ 34.64	19.66
ASBESTOS; HAZARDOUS/TOXIC WASTE PROJECTS		
GROUP 4 - A & B.....	\$ 30.70	19.66
ASBESTOS; HAZARDOUS/TOXIC WASTE PROJECTS		
GROUP 5 - A & B.....	\$ 27.30	19.66
HAZARDOUS/TOXIC WASTE PROJECTS		
GROUP 1 - C & D.....	\$ 35.96	19.66
HAZARDOUS/TOXIC WASTE PROJECTS		
GROUP 2 - C & D.....	\$ 35.66	19.66
HAZARDOUS/TOXIC WASTE PROJECTS		
GROUP 3 - C & D.....	\$ 31.76	19.66
HAZARDOUS/TOXIC WASTE PROJECTS		
GROUP 4 - C & D.....	\$ 28.14	19.66
HAZARDOUS/TOXIC WASTE PROJECTS		
GROUP 5 - C & D.....	\$ 25.03	19.66
ALL OTHER WORK		
GROUP 1.....	\$ 32.69	19.66

ALL OTHER WORK

GROUP 2.....\$ 32.42 19.66
ALL OTHER WORK

GROUP 3.....\$ 28.87 19.66
ALL OTHER WORK

GROUP 4.....\$ 25.58 19.66
ALL OTHER WORK

GROUP 5.....\$ 22.75 19.66

GROUP 1 - Rig, Pile Driver or Caisson Type; & Rig, Pile Hydraulic Unit Attached

GROUP 2 - Asphalt Heater Planer; Backfiller with Drag Attachment; Backhoe; Backhoe with Shear attached; Backhoe-Rear Pivotal Swing; Batch Plant-Central Mix Concrete; Batch Plant, Portable concrete; Berm Builder-Automatic; Boat Derrick; Boat-Tug; Boring Machine Attached to Tractor; Bullclam; Bulldozer; C.M.I. Road Builder & Similar Type; Cable Placer & Layer; Carrier-Straddle; Carryall-Scraper or Scoop; Chicago Boom; Compactor with Blade Attached; Concrete Saw (Vermeer or similar type); Concrete Spreader Finisher; Combination, Bidwell Machine; Crane; Crane-Electric Overhead; Crane-Rough Terrain; Crane-Side Boom; Crane-Truck; Crane-Tower; Derrick-Boom; Derrick-Car; Digger-Wheel (Not trencher or road widener); Double Nine; Drag Line; Dredge; Drill-Kenny or Similar Type; Easy Pour Median Barrier Machine (or similar type); Electromatic; Frankie Pile; Gradall; Grader; Gurry; Self-Propelled; Heavy Equipment Robotics Operator/Mechanic; Hoist-Monorail; Hoist-Stationary & Mobile Tractor; Hoist, 2 or 3 drum; Horizontal Directional Drill Operator; Jackall; Jumbo Machine; Kocal & Kuhlman; Land-Seagoing Vehicle; Loader, Elevating; Loader, Front End; Loader, Skid Steer; Locomotive; Mechanic/Welder; Metro Chip Harvester with Boom; Mucking Machine; Paver-Asphalt Finishing Machine; Paver-Road Concrete; Paver-Slip Form (C.M.I. or similar); Place Crete Machine with Boom; Post Driver (Carrier mounted); Power Driven Hydraulic Pump & Jack (When used in Slip Form or Lift Slab Construction); Pump Crete Machine; Regulator-Ballast; Hydraulic Power Unit not attached to Rig for Pile Drillings; Rigs-Drilling; Roto Mill or similar Full Lane (8' Wide & Over); Roto Mill or similar type (Under 8'); Shovel; Slip Form Curb Machine; Speedwing; Spikemaster; Stonecrusher; Tie Puller & Loader; Tie Tamper; Tractor-Double Boom; Tractor with Attachments; Truck-Boom; Truck-Tire; Trench Machine; Tunnel Machine (Mark 21 Java or similar); & Whirley (or similar type)

GROUP 3 - Asphalt Plant; Bending Machine (Pipeline or similar type); Boring machine, Motor Driven; Chip Harvester without Boom; Cleaning Machine, Pipeline Type; Coating Machine, Pipeline Type; Compactor; Concrete Belt Placer; Concrete Finisher; Concrete Planer or Asphalt; Concrete Spreader; Elevator; Fork Lift (Home building only); Fork lift & Lulls; Fork Lift Walk Behind (Hoisting over 1 buck high); Form Line Machine; Grease Truck operator; Grout Pump; Gunnite Machine; Horizontal Directional Drill

Locator; Single Drum Hoist with or without Tower; Huck Bolting Machine; Hydraulic Scaffold (Hoisting building materials); Paving Breaker (Self-propelled or Ridden); Pipe Dream; Pot Fireperson (Power Agitated); Refrigeration Plant; Road Widener; Roller; Sasgen Derrick; Seeding Machine; Soil Stabilizer (Pump type); Spray Cure Machine, Self-Propelled; Straw Blower Machine; Sub-Grader; Tube Finisher or Broom C.M.I. or similar type; & Tugger Hoist

GROUP 4 - Air Curtain Destructor & Similar Type; Batch Plant-Job Related; Boiler Operator; Compressor; Conveyor; Curb Builder, self-propelled; Drill Wagon; Generator Set; Generator-Steam; Heater-Portable Power; Hydraulic Manipulator Crane; Jack-Hydraulic Power driven; Jack-Hydraulic (Railroad); Ladavator; Minor Machine Operator; Mixer-Concrete; Mulching Machine; Pin Puller; Power Broom; Pulverizer; Pump; Road Finishing Machine (Pull Type); Saw-Concrete-Self-Propelled (Highway Work); Signal Person; Spray Cure Machine-Motor Powered; Stump Cutter; Tractor; Trencher Form; Water Blaster; Steam Jenny; Syphon; Vibrator-Gasoline; & Welding Machine

GROUP 5 - Brakeperson; Fireperson; & Oiler

IRON0017-002 05/01/2020

ASHTABULA (North of Route 6, starting at the Geauga County Line, proceeding east to State Route 45), CUYAHOGA, ERIE (Eastern 2/3), GEAUGA, HURON (East of a line drawn from the north border through Monroeville & Willard), LAKE, LORAIN, MEDINA (North of Old Rte. #224), PORTAGE (West of a line from Middlefield to Shalersville to Deerfield), and SUMMIT (North of Old Rte. #224, including city limits of Barberton) COUNTIES

Rates Fringes

IRONWORKER

Ornamental, Reinforcing, &
Structural.....\$ 35.93 23.11

IRON0017-010 05/01/2020

ASHTABULA (Eastern part from Lake Erie on the north to route #322 on the south to include Conneaut, Kingsville, Sheffield, Denmark, Dorset, Cherry Valley, Wayne, Monroe, Pierpont, Richmond, Andover & Williamsfield Townships)

Rates Fringes

IRONWORKER

Structural, including
metal building erection &
Reinforcing.....\$ 35.93 23.11

IRON0044-001 06/01/2018

ADAMS (Western Part), BROWN, BUTLER (Southern Part), CLERMONT, CLINTON (South of a line drawn from Blanchester to Lynchburg), HAMILTON, HIGHLAND (Excluding eastern one-fifth & portion of

county inside lines drawn from Marshall to Lynchburg from the northern county line through E. Monroe to Marshall) and WARREN (South of a line drawn from Blanchester through Morrow to the west county line) COUNTIES

	Rates	Fringes
IRONWORKER, REINFORCING		
Beyond 30-mile radius of Hamilton County Courthouse..	\$ 28.67	21.20
Up to & including 30-mile radius of Hamilton County Courthouse.....	\$ 27.60	20.70

IRON0044-002 06/01/2020

CLINTON (South of a line drawn from Blanchester to Lynchburg), HAMILTON, HIGHLAND (Excluding eastern one-fifth & portion of county inside lines drawn from Marshall to Lynchburg from the northern county line through E. Monroe to Marshall) & WARREN (South of a line drawn from Blanchester through Morrow to the west county line)

	Rates	Fringes
IRONWORKER		
Fence Erector.....	\$ 28.76	21.40
Ornamental; Structural.....	\$ 30.27	21.40

IRON0055-003 07/01/2019

CRAWFORD (Area Between lines drawn from where Hwy #598 & #30 meet through N. Liberty to the northern border & from said Hwy junction point due west to the border), DEFIANCE (S. of a line drawn from where Rte. #66 meets the northern line through Independence to the eastern county border), ERIE (Western 1/3), FULTON, HANCOCK, HARDIN (North of a line drawn from Maysville to a point 4 miles south of the northern line on the eastern line), HENRY, HURON (West of a line drawn from the northern border through Monroeville & Willard), LUCAS, OTTAWA, PUTNAM (East of a line drawn from the northern border down through Miller City to where #696 meets the southern border), SANDUSKY, SENECA, WILLIAMS (East of a line drawn from Pioneer through Stryker to the southern border), WOOD & WYANDOT (North of Rte. #30)

	Rates	Fringes
IRONWORKER		
Fence Erector.....	\$ 21.30	20.92
Flat Road Mesh.....	\$ 29.77	21.30
Tunnels & Caissons Under Pressure.....	\$ 29.77	21.30
All Other Work.....	\$ 30.38	24.40

IRON0147-002 06/01/2020

ALLEN (Northern half), DEFIANCE (Northern part, excluding south of a line drawn from where Rte. #66 meets the northern line

through Independence to the eastern county border), MERCER (Northern half), PAULDING, PUTNAM (Western part, excluding east of a line drawn from the northern border down through Miller City to where #696 meets the southern border), VAN WERT, and WILLIAMS (Western part, excluding east of a line drawn from Pioneer through Stryker to the southern border) COUNTIES

	Rates	Fringes
IRONWORKER.....	\$ 29.58	23.27

IRON0172-002 06/01/2020

CHAMPAIGN (Eastern one-third), CLARK (Eastern one-fourth), COSHOCTON (West of a line beginning at the northwestern county line going through Walhonding & Tunnel Hill to the southern county line), CRAWFORD (South of Rte. #30), DELAWARE, FAIRFIELD, FAYETTE, FRANKLIN, HARDIN (Excluding a line drawn from Roundhead to Maysville), HIGHLAND (Eastern one-fifth), HOCKING, JACKSON (Northern half), KNOX, LICKING, LOGAN (Eastern one-third), MADISON, MARION, MORROW, MUSKINGUM (West of a line starting at Adams Mill going to Adamsville & going from Adamsville through Blue Rock to the southern border), PERRY, PICKAWAY, PIKE (Northern half), ROSS, UNION, VINTON and WYANDOT (South of Rte. #30) COUNTIES

	Rates	Fringes
IRONWORKER.....	\$ 30.75	20.80

IRON0207-004 06/01/2020

ASHTABULA (Southern part starting at the Geauga County line), COLUMBIANA (E. of a line from Damascus to Highlandtown), MAHONING (N. of Old Route #224), PORTAGE (E. of a line from Middlefield to Shalersville to Deerfield) & TRUMBULL

	Rates	Fringes
IRONWORKER		
Layout; Sheeter.....	\$ 31.25	25.75
Ornamental; Reinforcing;		
Structural.....	\$ 28.06	24.70
Ornamental; Reinforcing....	\$ 30.25	25.75

IRON0290-002 06/01/2020

ALLEN (Southern half), AUGLAIZE, BUTLER (North of a line drawn from east to the west county line going through Oxford, Darrtown & Woodsdale), CHAMPAIGN (Excluding east of a line drawn from Catawla to the point where #68 intersects the northern county line), CLARK (Western two-thirds), CLINTON (Excluding south of a line drawn from Blanchester to Lynchburg), DARKE, GREENE, HIGHLAND (Inside lines drawn from Marshall to Lynchburg & from the northern county line through East Monroe to Marshall), LOGAN (West of a line drawn from West Liberty to where the northern county line meets the western county line of Hardin), MERCER (Southern half), MIAMI, MONTGOMERY, PREBLE, SHELBY & WARREN (Excluding south of a line

drawn from Blanchester through Morrow to the western county line) COUNTIES

	Rates	Fringes
IRONWORKER.....	\$ 29.68	22.90

* IRON0549-003 12/01/2020

BELMONT, GUERNSEY, HARRISON, JEFFERSON, MONROE & MUSKINGUM
(Excluding portion west of a line starting at Adams Mill going to Adamsville and going from Adamsville through Blue Rock to the south border)

	Rates	Fringes
IRONWORKER.....	\$ 34.03	23.22

IRON0550-004 05/01/2020

ASHLAND, CARROLL, COLUMBIANA (W. of a line from Damascus to Highlandtown), COSHOCTON (E. of a line beginning at NW Co. line going through Walhonding & Tunnel Hill to the South Co. line), HOLMES, HURON (S. of Old Rte. #224), MAHONING (S. of Old Rte. #224), MEDINA (S. of Old Rte. #224), PORTAGE (S. of Old Rte. #224), RICHLAND, STARK, SUMMIT (S. of Old Rte. #224, Excluding city limits of Barberton), TUSCARAWAS, & WAYNE

	Rates	Fringes
Ironworkers:Structural, Ornamental and Reinforcing.....	\$ 29.27	20.87

IRON0769-004 06/01/2020

ADAMS (Eastern Half), GALLIA, JACKSON (Southern Half), LAWRENCE & SCIOTO

	Rates	Fringes
IRONWORKER.....	\$ 32.75	26.34

IRON0787-003 12/01/2020

ATHENS, MEIGS, MORGAN, NOBLE, and WASHINGTON COUNTIES

	Rates	Fringes
IRONWORKER.....	\$ 30.98	22.75

LABO0265-008 05/01/2018

	Rates	Fringes
LABORER ASHTABULA, ERIE, HURON, LORAIN, LUCAS, MAHONING, MEDINA, OTTAWA, PORTAGE,		

SANDUSKY, STARK, SUMMIT, TRUMBULL & WOOD COUNTIES		
GROUP 1.....	\$ 31.05	10.95
GROUP 2.....	\$ 31.22	10.95
GROUP 3.....	\$ 31.55	10.95
GROUP 4.....	\$ 32.00	10.95
CUYAHOGA AND GEAUGA COUNTIES ONLY: SEWAGE PLANTS, WASTE PLANTS, WATER TREATMENT FACILITIES, PUMPING STATIONS, & ETHANOL PLANTS		
CONSTRUCTION.....	\$ 33.66	10.95
CUYAHOGA, GEAUGA & LAKE COUNTIES		
GROUP 1.....	\$ 32.28	10.95
GROUP 2.....	\$ 32.45	10.95
GROUP 3.....	\$ 32.78	10.95
GROUP 4.....	\$ 33.23	10.95
REMAINING COUNTIES OF OHIO		
GROUP 1.....	\$ 30.62	10.95
GROUP 2.....	\$ 30.79	10.95
GROUP 3.....	\$ 31.12	10.95
GROUP 4.....	\$ 31.57	10.95

LABORER CLASSIFICATIONS

GROUP 1 - Asphalt Laborer; Carpenter Tender; Concrete Curing Applicator; Dump Man (Batch Truck); Guardrail and Fence Installer; Joint Setter; Laborer (Construction); Landscape Laborer; Mesh Handlers & Placer; Right-of-way Laborer; Riprap Laborer & Grouter; Scaffold Erector; Seal Coating; Surface Treatment or Road Mix Laborer; Sign Installer; Slurry Seal; Utility Man; Bridge Man; Handyman; Waterproofing Laborer; Flagperson; Hazardous Waste (level D); Diver Tender; Zone Person & Traffic Control

GROUP 2 - Asphalt Raker; Concrete Puddler; Kettle Man Pipeline); Machine Driven Tools (Gas, Electric, Air); Mason Tender; Brick Paver; Mortar Mixer; Power Buggy or Power Wheelbarrow; Paint Striper; Sheeting & Shoring Man; Surface Grinder Man; Plastic Fusing Machine Operator; Pug Mill Operator; & Vacuum Devices (wet or dry); Rodding Machine Operator; Diver; Screwman or Paver; Screed Person; Water Blast, Hand Held Wand; Pumps 4" & Under (Gas, Air or Electric) & Hazardous Waste (level C); Air Track and Wagon Drill; Bottom Person; Cofferdam (below 25 ft. deep); Concrete Saw Person; Cutting with Burning Torch; Form Setter; Hand Spiker (Railroad); Pipelayer; Tunnel Laborer (without air) & Caisson; Underground Person (working in Sewer and Waterline, Cleaning, Repairing & Reconditioning); Sandblaster Nozzle Person; & Hazardous Waste (level B)

GROUP 3 - Blaster; Mucker; Powder Person; Top Lander; Wrencher (Mechanical Joints & Utility Pipeline); Yarner; Hazardous Waste (level A); Concrete Specialist; Concrete Crew in Tunnels (With Air-pressurized - \$1.00 premium); Curb Setter & Cutter; Grade Checker; Utility Pipeline Tapper; Waterline; and Caulker

GROUP 4 - Miner (With Air-pressurized - \$1.00 premium); & Gunite Nozzle Person

TUNNEL LABORER WITH AIR-PRESSURIZED ADD \$1.00 TO BASE RATE

SIGNAL PERSON WILL RECEIVE THE RATE EQUAL TO THE RATE PAID
THE LABORER CLASSIFICATION FOR WHICH HE OR SHE IS SIGNALING.

PAIN0006-002 05/01/2018

ASHTABULA, CUYAHOGA, GEAUGA, LAKE, LORAIN, PORTAGE (N. of the
East-West Turnpike) & SUMMIT (N. of the East-West Turnpike)

	Rates	Fringes
PAINTER		
COMMERCIAL NEW WORK; REMODELING; & RENOVATIONS		
GROUP 1.....	\$ 27.90	16.16
GROUP 2.....	\$ 28.30	16.16
GROUP 3.....	\$ 28.60	16.16
GROUP 4.....	\$ 34.16	16.16
COMMERCIAL REPAINT		
GROUP 1.....	\$ 26.40	16.16
GROUP 2.....	\$ 26.80	16.16
GROUP 3.....	\$ 27.10	16.16

PAINTER CLASSIFICATIONS - COMMERCIAL NEW WORK; REMODELING; &
RENOVATIONS

GROUP 1 - Brush; & Roller

GROUP 2 - Sandblasting & Buffing

GROUP 3 - Spray Painting; Closed Steel Above 55 feet; Bridges
& Open Structural Steel; Tanks - Water Towers; Bridge
Painters; Bridge Riggers; Containment Builders

GROUP 4 - Bridge Blaster

PAINTER CLASSIFICATIONS - COMMERCIAL REPAINT

GROUP 1 - Brush; & Roller

GROUP 2 - Sandblasting & Buffing

GROUP 3 - Spray Painting

PAIN0007-002 07/01/2019

FULTON, HENRY, LUCAS, OTTAWA (Excluding Allen, Bay, Bono,
Catawba Island, Clay Center, Curtice, Danbury, Eagle Beach,
Elliston, Elmore, Erie, Fishback, Gem Beach & Genova) & WOOD

	Rates	Fringes
PAINTER		
NEW COMMERCIAL WORK		
GROUP 1.....	\$ 27.64	17.79
GROUP 2.....	\$ 27.39	17.79

GROUP 3.....	\$ 27.39	17.79
GROUP 4.....	\$ 27.39	17.79
GROUP 5.....	\$ 27.39	17.79
GROUP 6.....	\$ 27.39	17.79
GROUP 7.....	\$ 27.39	17.79
GROUP 8.....	\$ 27.39	17.79
GROUP 9.....	\$ 27.39	17.79

REPAINT IS 90% OF JR

PAINTER CLASSIFICATIONS

GROUP 1 - Brush; Spray & Sandblasting Pot Tender

GROUP 2 - Refineries & Refinery Tanks; Surfaces 30 ft. or over where material is applied to or labor performed on above ground level (exterior), floor level (interior)

GROUP 3 - Swing Stage & Chair

GROUP 4 - Lead Abatement

GROUP 5 - All Methods of Spray

GROUP 6 - Solvent-Based Catalized Epoxy Materials of 2 or More Component Materials, to include Solvent-Based Conversion Varnish (excluding water based)

GROUP 7 - Spray Solvent Based Material; Sand & Abrasive Blasting

GROUP 8 - Towers; Tanks; Bridges; Stacks Over 30 Feet

GROUP 9 - Epoxy Spray (excluding water based)

PAIN0012-008 05/01/2019

BUTLER COUNTY

Rates Fringes

PAINTER

GROUP 1.....	\$ 21.95	10.20
GROUP 2.....	\$ 25.30	10.20
GROUP 3.....	\$ 25.80	10.20
GROUP 4.....	\$ 26.05	10.20
GROUP 5.....	\$ 26.30	10.20

PAINTER CLASSIFICATIONS

GROUP 1: Bridge Equipment Tender; Bridge/Containment Builder

GROUP 2: Brush & Roller

GROUP 3: Spray

GROUP 4: Sandblasting; & Waterblasting

GROUP 5: Elevated Tanks; Steeplejack Work; Bridge; & Lead Abatement

PAIN0012-010 05/01/2019

BROWN, CLERMONT, CLINTON, HAMILTON & WARREN

	Rates	Fringes
PAINTER		
HEAVY & HIGHWAY BRIDGES-		
GUARDRAILS-LIGHTPOLES-		
STRIPING		
Bridge Equipment Tender and Containment Builder....	\$ 21.95	10.20
Bridges when highest point of clearance is 60 feet or more; & Lead Abatement Projects.....	\$ 26.30	10.20
Brush & Roller.....	\$ 25.30	10.20
Sandblasting & Hopper Tender; Water Blasting....	\$ 26.05	10.20
Spray.....	\$ 25.80	10.20

PAIN0093-001 12/01/2018

ATHENS, GUERNSEY, HOCKING, MONROE, MORGAN, NOBLE and
WASHINGTON COUNTIES

	Rates	Fringes
PAINTER		
Bridges; Locks; Dams; Tension Towers; & Energized Substations.....		
	\$ 34.04	18.50
Power Generating Facilities.	\$ 30.89	18.50

PAIN0249-002 06/01/2020

CLARK, DARKE, GREENE, MIAMI, MONTGOMERY & PREBLE

	Rates	Fringes
PAINTER		
GROUP 1 - Brush & Roller....	\$ 24.17	11.22
GROUP 2 - Swing, Scaffold Bridges; Structural Steel; Open Acid Tank; High Tension Electrical Equipment; & Hot Pipes.....	\$ 24.17	11.22
GROUP 3 - Spray; Sandblast; Steamclean; Lead Abatement.....	\$ 24.92	11.22
GROUP 4 - Steeplejack Work..	\$ 25.12	11.22
GROUP 5 - Coal Tar.....	\$ 25.67	11.22
GROUP 6 - Bridge Equipment Tender & or Containment Builder.....	\$ 32.88	11.22
GROUP 7 - Tanks, Stacks & Towers.....	\$ 27.81	11.22

GROUP 8 - Bridge Blaster,
Rigger.....\$ 35.88 11.22

PAIN0356-002 09/01/2009

KNOX, LICKING, MUSKINGUM, and PERRY

Rates Fringes

PAINTER

Bridge Equipment Tenders and Containment Builders....	\$ 27.93	7.25
Bridges; Blasters; and Riggers.....	\$ 34.60	7.25
Brush and Roller.....	\$ 20.93	7.25
Sandblasting; Steam Cleaning; Waterblasting; and Hazardous Work.....	\$ 25.82	7.25
Spray.....	\$ 21.40	7.25
Structural Steel and Swing Stage.....	\$ 25.42	7.25
Tanks; Stacks; and Towers...	\$ 28.63	7.25

PAIN0438-002 12/01/2018

BELMONT, HARRISON and JEFFERSON COUNTIES

Rates Fringes

PAINTER

Bridges, Locks, Dams, Tension Towers & Energized Substations.....	\$ 32.80	17.68
Power Generating Facilities.	\$ 29.65	17.68

PAIN0476-001 06/01/2020

COLUMBIANA, MAHONING, and TRUMBULL COUNITIES

Rates Fringes

PAINTER

GROUP 1.....	\$ 26.47	14.53
GROUP 2.....	\$ 33.10	14.53
GROUP 3.....	\$ 26.68	14.53
GROUP 4.....	\$ 27.12	14.53
GROUP 5.....	\$ 27.12	14.53
GROUP 6.....	\$ 27.37	14.53
GROUP 7.....	\$ 28.47	14.53

PAINTER CLASSIFICATIONS:

GROUP 1: Painters, Brush & Roller

GROUP 2: Bridges

GROUP 3: Structural Steel

GROUP 4: Spray, Except Bar Joist/Deck

GROUP 5: Epoxy/Mastic; Spray- Bar Joist/Deck; Working Above
50 Feet; and Swingstages

GROUP 6: Tanks; Sandblasting

GROUP 7: Towers; Stacks

PAIN0555-002 09/01/2020

ADAMS, HIGHLAND, JACKSON, PIKE & SCIOTO

	Rates	Fringes
PAINTER		
GROUP 1.....	\$ 31.48	16.46
GROUP 2.....	\$ 32.97	16.46
GROUP 3.....	\$ 34.46	16.46
GROUP 4.....	\$ 37.38	16.46

PAINTER CLASSIFICATIONS

GROUP 1 - Containment Builder

GROUP 2 - Brush; Roller; Power Tools, Under 40 feet

GROUP 3 - Sand Blasting; Spray; Steam Cleaning; Pressure Washing; Epoxy & Two Component Materials; Lead Abatement; Hazardous Waste; Toxic Materials; Bulk & Storage Tanks of 25,000 Gallon Capacity or More; Elevated Tanks

GROUP 4 - Stacks; Bridges

PAIN0639-001 05/01/2011

	Rates	Fringes
Sign Painter & Erector.....	\$ 20.61	3.50+a+b+c

FOOTNOTES: a. 7 Paid Holidays: New Year's Day; Memorial Day; July 4th; Labor Day; Thanksgiving Day; Christmas Day & 1 Floating Day

b. Vacation Pay: After 1 year's service - 5 days' paid vacation; After 2, but less than 10 years' service - 10 days' paid vacation; After 10, but less than 20 years' service - 15 days' paid vacation; After 20 years' service - 20 days' paid vacation

c. Funeral leave up to 3 days maximum paid leave for death of mother, father, brother, sister, spouse, child, mother-in-law, father-in-law, grandparent and inlaw provided employee attends funeral

PAIN0788-002 06/01/2020

ASHLAND, CRAWFORD, ERIE, HANCOCK, HURON, MARION, MORROW, OTTAWA (Allen, Bay, Bono, Catawba Island, Clay Center, Curtice, Danbury, Eagle Beach, Elliston, Elmore, Erie, Fishback, Gem Beach & Genoa), RICHLAND, SANDUSKY, SENECA & WYANDOT

Rates Fringes

PAINTER

Brush & Roller.....	\$ 24.66	14.05
Structural Steel.....	\$ 26.26	14.05

WINTER REPAINT: Between December 1 to March 31 - 90%JR

\$.50 PER HOUR SHALL BE ADDED TO THE RATE OF PAY FOR THE CLASSIFICATION OF WORK:

While working swingstage, boatswain chair, needle beam and horizontal cable. While operating sprayguns, sandblasting, cobblasting and high pressure waterblasting (4000psi).

\$1.00 PER HOUR SHALL BE ADDED TO THE RATE OF PAY FOR THE CLASSIFICATION OF WORK:

For the application of catalized epoxy, including latex epoxy that is deemed hazardous, lead abatement, or for work or material where special precautions beyond normal work duties must be taken. For working on stacks, tanks, and towers over 40 feet in height.

PAIN0813-005 12/01/2008

GALLIA, LAWRENCE, MEIGS & VINTON

	Rates	Fringes
PAINTER		
Base Rate.....	\$ 24.83	10.00
Bridges, Locks, Dams & Tension Towers.....	\$ 27.83	10.00

PAIN0841-001 06/01/2018

MEDINA, PORTAGE (South of and including Ohio Turnpike), and SUMMIT (South of and including Ohio Turnpike) COUNTIES

	Rates	Fringes
Painters:		
GROUP 1.....	\$ 25.75	14.35
GROUP 2.....	\$ 26.40	14.35
GROUP 3.....	\$ 26.50	14.35
GROUP 4.....	\$ 26.60	14.35
GROUP 5.....	\$ 27.00	14.35
GROUP 6.....	\$ 39.20	11.75
GROUP 7.....	\$ 27.00	14.35

PAINTER CLASSIFICATIONS:

GROUP 1 - Brush, Roller & Paperhanger

GROUP 2 - Epoxy Application

GROUP 3 - Swing Scaffold, Bosum Chair, & Window Jack

GROUP 4 - Spray Gun Operator of Any & All Coatings

GROUP 5 - Sandblast, Painting of Standpipes, etc. from

Scaffolds, Bridge Work and/or Open Structural Steel,
Standpipes and/or Water Towers

GROUP 6 - Public & Commerce Transportation, Steel or
Galvanized, Bridges, Tunnels & Related Support Items
(concrete)

GROUP 7 - Synthetic Exterior, Drywall Finisher and/or Taper,
Drywall Finisher and Follow-up Man Using Automatic Tools

PAIN0841-002 06/01/2018

CARROLL, COSHOCTON, HOLMES, STARK, TUSCARAWAS & WAYNE

	Rates	Fringes
PAINTER		
Bridges; Towers, Poles & Stacks; Sandblasting Steel; Structural Steel & Metalizing.....	\$ 22.78	13.63
Brush & Roller.....	\$ 21.77	13.63
Spray; Tank Interior & Exterior.....	\$ 22.60	13.63

PAIN1020-002 07/01/2020

ALLEN, AUGLAIZE, CHAMPAIGN, DEFIANCE, HARDIN, LOGAN, MERCER,
PAULDING, PUTNAM, SHELBY, VAN WERT, and WILLIAMS COUNTIES

	Rates	Fringes
PAINTER		
Brush & Roller.....	\$ 25.22	14.11
Drywall Finishing & Taping..	\$ 23.92	14.11
Lead Abatement.....	\$ 26.97	14.11
Spray, Sandblasting Pressure Cleaning, & Refinery.....	\$ 25.87	14.11
Swing Stage, Chair, Spiders, & Cherry Pickers...	\$ 25.47	14.11
Wallcoverings.....	\$ 22.82	14.11

All surfaces 40 ft. or over where material is applied to or
labor performed on, above ground level (exterior), floor
level (interior) - \$.50 premium

Applying Coal Tar Products - \$1.00 premium

PAIN1275-002 06/01/2020

DELAWARE, FAIRFIELD, FAYETTE, FRANKLIN, MADISON, PICKAWAY, ROSS
& UNION

	Rates	Fringes
PAINTER		
Bridges.....	\$ 34.64	14.40

Brush; Roller.....	\$ 25.16	14.40
Sandblasting; Steamcleaning; Waterblasting (3500 PSI or Over)& Hazardous Work.....	\$ 25.86	14.40
Spray.....	\$ 25.66	14.40
Stacks; Tanks; & Towers.....	\$ 28.67	14.40
Structural Steel & Swing Stage.....	\$ 25.46	14.40

PLAS0109-001 05/01/2018

MEDINA, PORTAGE, STARK, and SUMMIT COUNTIES

	Rates	Fringes
PLASTERER.....	\$ 28.86	17.11

PLAS0109-003 05/01/2018

CARROLL, HOLMES, TUSCARAWAS, and WAYNE COUNTIES

	Rates	Fringes
PLASTERER.....	\$ 28.21	17.11

PLAS0132-002 05/01/2018

BROWN, BUTLER, CLERMONT, HAMILTON, HIGHLAND, WARREN COUNTIES

	Rates	Fringes
PLASTERER.....	\$ 28.86	17.11

PLAS0404-002 05/01/2018

ASHTABULA, CUYAHOGA, GEAUGA, AND LAKE COUNTIES

	Rates	Fringes
PLASTERER.....	\$ 29.63	17.11

PLAS0404-003 05/01/2018

LORAIN COUNTY

	Rates	Fringes
PLASTERER.....	\$ 28.86	17.11

PLAS0526-022 05/01/2018

COLUMBIANA, MAHONING, and TRUMBULL COUNTIES

	Rates	Fringes
PLASTERER.....	\$ 28.86	17.11

PLAS0526-023 05/01/2018

BELMONT, HARRISON, and JEFFERSON COUNTIES

	Rates	Fringes
PLASTERER.....	\$ 28.21	17.11

PLAS0886-001 05/01/2018		

FULTON, HANCOCK, HENRY, LUCAS, PUTNAM, and WOOD COUNTIES

	Rates	Fringes
PLASTERER.....	\$ 29.63	17.11

PLAS0886-003 05/01/2018		

DEFIANCE, ERIE, HURON, OTTAWA, PAULDING, SANDUSKY, and SENECA COUNTIES

	Rates	Fringes
PLASTERER.....	\$ 28.86	17.11

PLAS0886-004 05/01/2018		

ALLEN, AUGLAIZE, HARDIN, LOGAN, MERCER, and VAN WERT COUNTIES

	Rates	Fringes
PLASTERER.....	\$ 28.21	17.11

PLUM0042-002 07/01/2018		

ASHLAND, CRAWFORD, ERIE, HURON, KNOX, LORAIN, MORROW, RICHLAND & WYANDOT

	Rates	Fringes
Plumber, Pipefitter, Steamfitter.....	\$ 34.20	22.07

PLUM0050-002 07/06/2020		

DEFIANCE, FULTON, HANCOCK, HENRY, LUCAS, OTTAWA, PAULDING, PUTNAM, SANDUSKY, SENECA, WILLIAMS & WOOD

	Rates	Fringes
Plumber, Pipefitter, Steamfitter.....	\$ 43.60	26.73

PLUM0055-003 05/04/2020		

ASHTABULA, CUYAHOGA, GEAUGA, LAKE, MEDINA (N. of Rte. #18 & Smith Road) & SUMMIT (N. of Rte. #303, including the corporate limits of the city of Hudson)

	Rates	Fringes
PLUMBER.....	\$ 37.07	27.71

PLUM0083-001 07/01/2017

BELMONT & MONROE (North of Rte. #78)

	Rates	Fringes
Plumber and Steamfitter.....	\$ 32.16	31.51

PLUM0094-002 05/01/2020

CARROLL (Northen Half), STARK, and WAYNE COUNTIES

	Rates	Fringes
PLUMBER/PIPEFITTER.....	\$ 35.78	21.44

PLUM0120-002 05/04/2020

ASHTABULA, CUYAHOGA, GEAUGA, LAKE, LORAIN (the C.E.I. Power House in Avon Lake), MEDINA (N. of Rte. #18) & SUMMIT (N. of #303)

	Rates	Fringes
PIPEFITTER.....	\$ 40.22	25.48

PLUM0162-002 06/01/2020

CHAMPAIGN, CLARK, CLINTON, DARKE, FAYETTE, GREENE, MIAMI, MONTGOMERY & PREBLE

	Rates	Fringes
Plumber, Pipefitter, Steamfitter.....	\$ 32.25	26.47

PLUM0168-002 06/01/2019

MEIGS, MONROE (South of Rte. #78), MORGAN (South of Rte. #78) & WASHINGTON

	Rates	Fringes
PLUMBER/PIPEFITTER.....	\$ 35.32	31.63

PLUM0189-002 06/01/2019

DELAWARE, FAIRFIELD, FRANKLIN, HOCKING, LICKING, MADISON, MARION, PERRY, PICKAWAY, ROSS & UNION

	Rates	Fringes
Plumber, Pipefitter, Steamfitter.....	\$ 38.45	16.98

PLUM0219-002 05/31/2018

MEDINA (Rte. #18 from eastern edge of Medina Co., west to eastern corporate limits of the city of Medina, & on the county road from the west corporate limits of Medina running due west to and through community of Risley to the western edge of Medina County - All territory south of this line), PORTAGE, and SUMMIT (S. of Rte. #303) COUNTIES

	Rates	Fringes
Plumber and Steamfitter.....	\$ 37.02	23.79

PLUM0392-002 06/01/2020		

BROWN, BUTLER, CLERMONT, HAMILTON & WARREN

	Rates	Fringes
PLUMBER/PIPEFITTER.....	\$ 33.91	22.29

PLUM0396-001 08/01/2020		

COLUMBIANA (Excluding Washington & Yellow Creek Townships & Liverpool Twp. - Secs. 35 & 36 - West of County Road #427), MAHONING and TRUMBULL COUNTIES

	Rates	Fringes
PLUMBER/PIPEFITTER.....	\$ 34.30	26.56

PLUM0495-002 06/01/2018		

CARROLL (Rose, Monroe, Union, Lee, Orange, Perry & Loudon Townships), COLUMBIANA (Washington & Yellow Creek Townships & Liverpool Township, Secs. 35 & 36, West of County Rd. #427), COSHOCTON, GUERNSEY, HARRISON, HOLMES, JEFFERSON, MORGAN (South to State Rte. #78 & from McConnelville west on State Rte. #37 to the Perry County line), MUSKINGUM, NOBLE, and TUSCARAWAS COUNTIES

	Rates	Fringes
Plumber, Pipefitter, Steamfitter.....	\$ 38.24	23.09

PLUM0577-002 06/01/2019		

ADAMS, ATHENS, GALLIA, HIGHLAND, JACKSON, LAWRENCE, PIKE, SCIOTO & VINTON

	Rates	Fringes
Plumber, Pipefitter, Steamfitter.....	\$ 34.90	24.11

* PLUM0776-002 07/01/2020		

ALLEN, AUGLAIZE, HARDIN, LOGAN, MERCER, SHELBY and VAN WERT COUNTIES

	Rates	Fringes
Plumber, Pipefitter, Steamfitter.....	\$ 37.63	25.58

TEAM0377-003 05/01/2020

STATEWIDE, EXCEPT CUYAHOGA, GEAUGA & LAKE

	Rates	Fringes
TRUCK DRIVER		
GROUP 1.....	\$ 28.89	15.40
GROUP 2.....	\$ 29.31	15.40

TRUCK DRIVER CLASSIFICATIONS

GROUP 1 - Asphalt Distributor; Batch; 4- Wheel Service;
4-Wheel Dump; Oil Distributor & Tandem

GROUP 2 - Tractor-Trailer Combination: Fuel; Pole Trailer;
Ready Mix; Semi-Tractor; & Asphalt Oil Spraybar Man When
Operated From Cab; 5 Axles & Over; Belly Dump; End Dump;
Articulated Dump; Heavy Duty Equipment; Low Boy; & Truck
Mechanic

TEAM0436-002 05/01/2020

CUYAHOGA, GEAUGA & LAKE

	Rates	Fringes
TRUCK DRIVER		
GROUP 1.....	\$ 29.55	16.95
GROUP 2.....	\$ 30.05	16.95

GROUP 1: Straight & Dump, Straight Fuel

GROUP 2: Semi Fuel, Semi Tractor, Euclids, Darts, Tank,
Asphalt Spreaders, Low Boys, Carry-All, Tourna-Rockers,
Hi-Lifts, Extra Long Trailers, Semi-Pole Trailers, Double
Hook-Up Tractor Trailers including Team Track & Railroad
Siding, Semi-Tractor & Tri-Axle Trailer, Tandem Tractor &
Tandem Trailer, Tag Along Trailer, Expandable Trailer or
Towing Requiring Road Permits, Ready-Mix (Agitator or
Non-Agitator), Bulk Concrete Driver, Dry Batch Truck,
Articulated End Dump

WELDERS - Receive rate prescribed for craft performing
operation to which welding is incidental.

=====
Note: Executive Order (EO) 13706, Establishing Paid Sick Leave
for Federal Contractors applies to all contracts subject to the
Davis-Bacon Act for which the contract is awarded (and any
solicitation was issued) on or after January 1, 2017. If this

contract is covered by the EO, the contractor must provide employees with 1 hour of paid sick leave for every 30 hours they work, up to 56 hours of paid sick leave each year. Employees must be permitted to use paid sick leave for their own illness, injury or other health-related needs, including preventive care; to assist a family member (or person who is like family to the employee) who is ill, injured, or has other health-related needs, including preventive care; or for reasons resulting from, or to assist a family member (or person who is like family to the employee) who is a victim of, domestic violence, sexual assault, or stalking. Additional information on contractor requirements and worker protections under the EO is available at www.dol.gov/whd/govcontracts.

Unlisted classifications needed for work not included within the scope of the classifications listed may be added after award only as provided in the labor standards contract clauses (29CFR 5.5 (a) (1) (ii)).

The body of each wage determination lists the classification and wage rates that have been found to be prevailing for the cited type(s) of construction in the area covered by the wage determination. The classifications are listed in alphabetical order of ""identifiers"" that indicate whether the particular rate is a union rate (current union negotiated rate for local), a survey rate (weighted average rate) or a union average rate (weighted union average rate).

Union Rate Identifiers

A four letter classification abbreviation identifier enclosed in dotted lines beginning with characters other than ""SU"" or ""UAVG"" denotes that the union classification and rate were prevailing for that classification in the survey. Example: PLUM0198-005 07/01/2014. PLUM is an abbreviation identifier of the union which prevailed in the survey for this classification, which in this example would be Plumbers. 0198 indicates the local union number or district council number where applicable, i.e., Plumbers Local 0198. The next number, 005 in the example, is an internal number used in processing the wage determination. 07/01/2014 is the effective date of the most current negotiated rate, which in this example is July 1, 2014.

Union prevailing wage rates are updated to reflect all rate changes in the collective bargaining agreement (CBA) governing this classification and rate.

Survey Rate Identifiers

Classifications listed under the ""SU"" identifier indicate that no one rate prevailed for this classification in the survey and the published rate is derived by computing a weighted average rate based on all the rates reported in the survey for that classification. As this weighted average rate includes all rates reported in the survey, it may include both union and non-union rates. Example: SULA2012-007 5/13/2014. SU indicates the rates are survey rates based on a weighted average

calculation of rates and are not majority rates. LA indicates the State of Louisiana. 2012 is the year of survey on which these classifications and rates are based. The next number, 007 in the example, is an internal number used in producing the wage determination. 5/13/2014 indicates the survey completion date for the classifications and rates under that identifier.

Survey wage rates are not updated and remain in effect until a new survey is conducted.

Union Average Rate Identifiers

Classification(s) listed under the UAVG identifier indicate that no single majority rate prevailed for those classifications; however, 100% of the data reported for the classifications was union data. EXAMPLE: UAVG-OH-0010 08/29/2014. UAVG indicates that the rate is a weighted union average rate. OH indicates the state. The next number, 0010 in the example, is an internal number used in producing the wage determination. 08/29/2014 indicates the survey completion date for the classifications and rates under that identifier.

A UAVG rate will be updated once a year, usually in January of each year, to reflect a weighted average of the current negotiated/CBA rate of the union locals from which the rate is based.

WAGE DETERMINATION APPEALS PROCESS

1.) Has there been an initial decision in the matter? This can be:

- * an existing published wage determination
- * a survey underlying a wage determination
- * a Wage and Hour Division letter setting forth a position on a wage determination matter
- * a conformance (additional classification and rate) ruling

On survey related matters, initial contact, including requests for summaries of surveys, should be with the Wage and Hour Regional Office for the area in which the survey was conducted because those Regional Offices have responsibility for the Davis-Bacon survey program. If the response from this initial contact is not satisfactory, then the process described in 2.) and 3.) should be followed.

With regard to any other matter not yet ripe for the formal process described here, initial contact should be with the Branch of Construction Wage Determinations. Write to:

Branch of Construction Wage Determinations
Wage and Hour Division
U.S. Department of Labor
200 Constitution Avenue, N.W.
Washington, DC 20210

2.) If the answer to the question in 1.) is yes, then an interested party (those affected by the action) can request

review and reconsideration from the Wage and Hour Administrator
(See 29 CFR Part 1.8 and 29 CFR Part 7). Write to:

Wage and Hour Administrator
U.S. Department of Labor
200 Constitution Avenue, N.W.
Washington, DC 20210

The request should be accompanied by a full statement of the interested party's position and by any information (wage payment data, project description, area practice material, etc.) that the requestor considers relevant to the issue.

3.) If the decision of the Administrator is not favorable, an interested party may appeal directly to the Administrative Review Board (formerly the Wage Appeals Board). Write to:

Administrative Review Board
U.S. Department of Labor
200 Constitution Avenue, N.W.
Washington, DC 20210

4.) All decisions by the Administrative Review Board are final.

=====

END OF GENERAL DECISION

"

"General Decision Number: KY20210073 01/01/2021

Superseded General Decision Number: KY20200073

State: Kentucky

Construction Type: Heavy

County: Kenton County in Kentucky.

HEAVY CONSTRUCTION PROJECTS (including sewer/water construction).

Note: Under Executive Order (EO) 13658, an hourly minimum wage of \$10.95 for calendar year 2021 applies to all contracts subject to the Davis-Bacon Act for which the contract is awarded (and any solicitation was issued) on or after January 1, 2015. If this contract is covered by the EO, the contractor must pay all workers in any classification listed on this wage determination at least \$10.95 per hour (or the applicable wage rate listed on this wage determination, if it is higher) for all hours spent performing on the contract in calendar year 2021. If this contract is covered by the EO and a classification considered necessary for performance of work on the contract does not appear on this wage determination, the contractor must pay workers in that classification at least the wage rate determined through the conformance process set forth in 29 CFR 5.5(a)(1)(ii) (or the EO minimum wage rate, if it is higher than the conformed wage rate). The EO minimum wage rate will be adjusted annually. Please note that this EO applies to the above-mentioned types of contracts entered into by the federal government that are subject to the Davis-Bacon Act itself, but it does not apply to contracts subject only to the Davis-Bacon Related Acts, including those set forth at 29 CFR 5.1(a)(2)-(60). Additional information on contractor requirements and worker protections under the EO is available at www.dol.gov/whd/govcontracts.

Modification Number	Publication Date
0	01/01/2021

* ASBE0008-007 03/01/2020

	Rates	Fringes
ASBESTOS WORKER/HEAT & FROST INSULATOR.....	\$ 30.07	18.75

ELEC0369-008 05/28/2019

	Rates	Fringes
ELECTRICIAN.....	\$ 32.44	17.22

ENGI0018-016 05/01/2019

Rates	Fringes
-------	---------

POWER EQUIPMENT OPERATOR (Backhoe/Excavator/Trackhoe).....\$ 37.39	14.95
---	-------

ENGI0181-016 07/01/2020

Rates Fringes

POWER EQUIPMENT OPERATOR GROUP 1.....\$ 35.14	17.25
--	-------

OPERATING ENGINEER CLASSIFICATIONS

GROUP 1 - Crane; Forklift

Operators on cranes with boom 150 feet and over, including jib, shall receive \$0.75 above Group 1. All cranes with piling leads will receive \$0.50 above Group 1 rate regardless of boom length. Combination rate shall mean \$0.50 per hour above the basic hourly rate of pay.

Employees assigned to work below ground level are to be paid 10% above basic wage rate. This does not apply to open cut work.

ENGI0181-019 07/01/2020

Rates Fringes

POWER EQUIPMENT OPERATOR GROUP 1.....\$ 33.95	17.25
GROUP 2.....\$ 31.09	17.25
GROUP 3.....\$ 31.54	17.25
GROUP 4.....\$ 30.77	17.25

OPERATING ENGINEER CLASSIFICATIONS

GROUP 1 - Drill; Pumpcrete; Roller (Bituminous)

GROUP 2 - Bobcat/Skid Steer/Skid Loader; Concrete Pump; Roller (Rock)

GROUP 3 - Articulating Truck Operator

GROUP 4 - Pump; Roller (Earth)

Operators on cranes with booms 150 feet and over (including jib) shall receive \$1.00 above Group 1 rate; 250 feet and over including jib shall receive \$1.50 above Class 1 rate. Combination Rate: All crane operators operating cranes, where the length of the boom in combination with the length of the piling leads equal or exceeds 150 feet, shall receive \$1.00 above the Group 1 rate.

Employees assigned to work below ground level are to be paid 10% above basic wage rate. This does not apply to open cut work.

IRON0044-005 06/01/2020

Rates Fringes

IRONWORKER (STRUCTURAL AND REINFORCING).....	\$ 30.47	21.20
--	----------	-------

IRON0070-011 06/01/2020

	Rates	Fringes
--	-------	---------

IRONWORKER, ORNAMENTAL.....	\$ 30.42	23.15
-----------------------------	----------	-------

LAB00189-016 07/01/2020

	Rates	Fringes
--	-------	---------

LABORER

Concrete Worker & Grade Checker.....	\$ 23.26	15.62
Tamper(Hand Held/Walk Behind).....	\$ 23.51	15.62

LAB00265-005 05/01/2015

	Rates	Fringes
--	-------	---------

LABORER

Concrete Saw (Hand Held/Walk Behind) & Pipelayer.....	\$ 28.89	9.85
Flagger & Landscape.....	\$ 28.72	9.85

SUKY2011-029 06/25/2014

	Rates	Fringes
--	-------	---------

CARPENTER (Form Work Only).....	\$ 24.80	8.76
LABORER: Common or General.....	\$ 25.27	8.34
LABORER: Concrete Finishing.....	\$ 25.75	8.60
OPERATOR: Bulldozer.....	\$ 28.04	13.00
OPERATOR: Loader.....	\$ 29.37	10.13
OPERATOR: Mechanic.....	\$ 28.60	11.83
OPERATOR: Oiler.....	\$ 24.34	13.00
OPERATOR: Trencher.....	\$ 26.27	12.37
TRUCK DRIVER: Dump Truck.....	\$ 19.00	4.78

WELDERS - Receive rate prescribed for craft performing operation to which welding is incidental.

=====
Note: Executive Order (EO) 13706, Establishing Paid Sick Leave for Federal Contractors applies to all contracts subject to the Davis-Bacon Act for which the contract is awarded (and any solicitation was issued) on or after January 1, 2017. If this

contract is covered by the EO, the contractor must provide employees with 1 hour of paid sick leave for every 30 hours they work, up to 56 hours of paid sick leave each year. Employees must be permitted to use paid sick leave for their own illness, injury or other health-related needs, including preventive care; to assist a family member (or person who is like family to the employee) who is ill, injured, or has other health-related needs, including preventive care; or for reasons resulting from, or to assist a family member (or person who is like family to the employee) who is a victim of, domestic violence, sexual assault, or stalking. Additional information on contractor requirements and worker protections under the EO is available at www.dol.gov/whd/govcontracts.

Unlisted classifications needed for work not included within the scope of the classifications listed may be added after award only as provided in the labor standards contract clauses (29CFR 5.5 (a) (1) (ii)).

The body of each wage determination lists the classification and wage rates that have been found to be prevailing for the cited type(s) of construction in the area covered by the wage determination. The classifications are listed in alphabetical order of ""identifiers"" that indicate whether the particular rate is a union rate (current union negotiated rate for local), a survey rate (weighted average rate) or a union average rate (weighted union average rate).

Union Rate Identifiers

A four letter classification abbreviation identifier enclosed in dotted lines beginning with characters other than ""SU"" or ""UAVG"" denotes that the union classification and rate were prevailing for that classification in the survey. Example: PLUM0198-005 07/01/2014. PLUM is an abbreviation identifier of the union which prevailed in the survey for this classification, which in this example would be Plumbers. 0198 indicates the local union number or district council number where applicable, i.e., Plumbers Local 0198. The next number, 005 in the example, is an internal number used in processing the wage determination. 07/01/2014 is the effective date of the most current negotiated rate, which in this example is July 1, 2014.

Union prevailing wage rates are updated to reflect all rate changes in the collective bargaining agreement (CBA) governing this classification and rate.

Survey Rate Identifiers

Classifications listed under the ""SU"" identifier indicate that no one rate prevailed for this classification in the survey and the published rate is derived by computing a weighted average rate based on all the rates reported in the survey for that classification. As this weighted average rate includes all rates reported in the survey, it may include both union and non-union rates. Example: SULA2012-007 5/13/2014. SU indicates the rates are survey rates based on a weighted average

calculation of rates and are not majority rates. LA indicates the State of Louisiana. 2012 is the year of survey on which these classifications and rates are based. The next number, 007 in the example, is an internal number used in producing the wage determination. 5/13/2014 indicates the survey completion date for the classifications and rates under that identifier.

Survey wage rates are not updated and remain in effect until a new survey is conducted.

Union Average Rate Identifiers

Classification(s) listed under the UAVG identifier indicate that no single majority rate prevailed for those classifications; however, 100% of the data reported for the classifications was union data. EXAMPLE: UAVG-OH-0010 08/29/2014. UAVG indicates that the rate is a weighted union average rate. OH indicates the state. The next number, 0010 in the example, is an internal number used in producing the wage determination. 08/29/2014 indicates the survey completion date for the classifications and rates under that identifier.

A UAVG rate will be updated once a year, usually in January of each year, to reflect a weighted average of the current negotiated/CBA rate of the union locals from which the rate is based.

WAGE DETERMINATION APPEALS PROCESS

1.) Has there been an initial decision in the matter? This can be:

- * an existing published wage determination
- * a survey underlying a wage determination
- * a Wage and Hour Division letter setting forth a position on a wage determination matter
- * a conformance (additional classification and rate) ruling

On survey related matters, initial contact, including requests for summaries of surveys, should be with the Wage and Hour Regional Office for the area in which the survey was conducted because those Regional Offices have responsibility for the Davis-Bacon survey program. If the response from this initial contact is not satisfactory, then the process described in 2.) and 3.) should be followed.

With regard to any other matter not yet ripe for the formal process described here, initial contact should be with the Branch of Construction Wage Determinations. Write to:

Branch of Construction Wage Determinations
Wage and Hour Division
U.S. Department of Labor
200 Constitution Avenue, N.W.
Washington, DC 20210

2.) If the answer to the question in 1.) is yes, then an interested party (those affected by the action) can request

review and reconsideration from the Wage and Hour Administrator
(See 29 CFR Part 1.8 and 29 CFR Part 7). Write to:

Wage and Hour Administrator
U.S. Department of Labor
200 Constitution Avenue, N.W.
Washington, DC 20210

The request should be accompanied by a full statement of the
interested party's position and by any information (wage
payment data, project description, area practice material,
etc.) that the requestor considers relevant to the issue.

3.) If the decision of the Administrator is not favorable, an
interested party may appeal directly to the Administrative
Review Board (formerly the Wage Appeals Board). Write to:

Administrative Review Board
U.S. Department of Labor
200 Constitution Avenue, N.W.
Washington, DC 20210

4.) All decisions by the Administrative Review Board are final.

=====

END OF GENERAL DECISION

"

"General Decision Number: KY20210038 01/01/2021

Superseded General Decision Number: KY20200038

State: Kentucky

Construction Type: Highway

Counties: Anderson, Bath, Bourbon, Boyd, Boyle, Bracken, Breckinridge, Bullitt, Carroll, Carter, Clark, Elliott, Fayette, Fleming, Franklin, Gallatin, Grant, Grayson, Greenup, Hardin, Harrison, Henry, Jefferson, Jessamine, Larue, Lewis, Madison, Marion, Mason, Meade, Mercer, Montgomery, Nelson, Nicholas, Oldham, Owen, Robertson, Rowan, Scott, Shelby, Spencer, Trimble, Washington and Woodford Counties in Kentucky.

HIGHWAY CONSTRUCTION PROJECTS (excluding tunnels, building structures in rest area projects & railroad construction; bascule, suspension & spandrel arch bridges designed for commercial navigation, bridges involving marine construction; and other major bridges).

Note: Under Executive Order (EO) 13658, an hourly minimum wage of \$10.95 for calendar year 2021 applies to all contracts subject to the Davis-Bacon Act for which the contract is awarded (and any solicitation was issued) on or after January 1, 2015. If this contract is covered by the EO, the contractor must pay all workers in any classification listed on this wage determination at least \$10.95 per hour (or the applicable wage rate listed on this wage determination, if it is higher) for all hours spent performing on the contract in calendar year 2021. If this contract is covered by the EO and a classification considered necessary for performance of work on the contract does not appear on this wage determination, the contractor must pay workers in that classification at least the wage rate determined through the conformance process set forth in 29 CFR 5.5(a)(1)(ii) (or the EO minimum wage rate, if it is higher than the conformed wage rate). The EO minimum wage rate will be adjusted annually. Please note that this EO applies to the above-mentioned types of contracts entered into by the federal government that are subject to the Davis-Bacon Act itself, but it does not apply to contracts subject only to the Davis-Bacon Related Acts, including those set forth at 29 CFR 5.1(a)(2)-(60). Additional information on contractor requirements and worker protections under the EO is available at www.dol.gov/whd/govcontracts.

Modification Number	Publication Date
0	01/01/2021

BRIN0004-003 06/01/2017

BRECKENRIDGE COUNTY

	Rates	Fringes
BRICKLAYER.....	\$ 26.80	12.38

* BRKY0001-005 06/01/2020

BULLITT, CARROLL, GRAYSON, HARDIN, HENRY, JEFFERSON, LARUE,
MARION, MEADE, NELSON, OLDHAM, SHELBY, SPENCER, & TRIMBLE
COUNTIES:

	Rates	Fringes
BRICKLAYER.....	\$ 31.00	14.86

* BRKY0002-006 06/01/2020

BRACKEN, GALLATIN, GRANT, MASON & ROBERTSON COUNTIES:

	Rates	Fringes
BRICKLAYER.....	\$ 31.00	14.86

BRKY0007-004 06/01/2017

BOYD, CARTER, ELLIOT, FLEMING, GREENUP, LEWIS & ROWAN COUNTIES:

	Rates	Fringes
BRICKLAYER.....	\$ 32.98	19.02

* BRKY0017-004 06/01/2020

ANDERSON, BATH, BOURBON, BOYLE, CLARK, FAYETTE, FRANKLIN,
HARRISON, JESSAMINE, MADISON, MERCER, MONTGOMERY, NICHOLAS,
OWEN, SCOTT, WASHINGTON & WOODFORD COUNTIES:

	Rates	Fringes
BRICKLAYER.....	\$ 31.00	14.86

CARP0064-001 04/01/2020

	Rates	Fringes
CARPENTER.....	\$ 29.81	19.96
Diver.....	\$ 45.09	19.96
PILEDRIVERMAN.....	\$ 30.06	19.96

ELEC0212-008 06/01/2020

BRACKEN, GALLATIN and GRANT COUNTIES

	Rates	Fringes
ELECTRICIAN.....	\$ 31.30	19.72

ELEC0212-014 11/25/2019

BRACKEN, GALLATIN & GRANT COUNTIES:

	Rates	Fringes
--	-------	---------

Sound & Communication

Technician.....	\$ 24.35	12.09

ELEC0317-012 06/01/2020		

BOYD, CARTER, ELLIOT & ROWAN COUNTIES:

	Rates	Fringes
ELECTRICIAN (Wiremen).....	\$ 35.10	26.22

ELEC0369-007 05/28/2019		

ANDERSON, BATH, BOURBON, BOYLE, BRECKINRIDGE, BULLITT, CARROLL, CLARK, FAYETTE, FRAONKLIN, GRAYSON, HARDIN, HARRISON, HENRY, JEFFERSON, JESSAMINE, LARUE, MADISON, MARION, MEADE, MERCER, MONTGOMERY, NELSON, NICHOLAS, OLDHAM, OWEN, ROBERTSON, SCOTT, SHELBY, SPENCER, TRIMBLE, WASHINGTON, & WOODFORD COUNTIES:

	Rates	Fringes
ELECTRICIAN.....	\$ 32.44	17.22

ELEC0575-002 11/30/2020		

FLEMING, GREENUP, LEWIS & MASON COUNTIES:

	Rates	Fringes
ELECTRICIAN.....	\$ 33.75	19.22

ENGI0181-018 07/01/2020		

	Rates	Fringes
POWER EQUIPMENT OPERATOR		
GROUP 1.....	\$ 33.95	17.25
GROUP 2.....	\$ 31.09	17.25
GROUP 3.....	\$ 31.54	17.25
GROUP 4.....	\$ 30.77	17.25

OPERATING ENGINEER CLASSIFICATIONS

GROUP 1 - A-Frame Winch Truck; Auto Patrol; Backfiller; Batcher Plant; Bituminous Paver; Bituminous Transfer Machine; Boom Cat; Bulldozer; Mechanic; Cableway; Carry-All Scoop; Carry Deck Crane; Central Compressor Plant; Cherry Picker; Clamshell; Concrete Mixer (21 cu. ft. or Over); Concrete Paver; Truck-Mounted Concrete Pump; Core Drill; Crane; Crusher Plant; Derrick; Derrick Boat; Ditching & Trenching Machine; Dragline; Dredge Operator; Dredge Engineer; Elevating Grader & Loaders; Grade-All; Gurrries; Heavy Equipment Robotics Operator/Mechanic; High Lift; Hoe-Type Machine; Hoist (Two or More Drums); Hoisting Engine (Two or More Drums); Horizontal Directional Drill Operator; Hydrocrane; Hyster; KeCal Loader; LeTourneau; Locomotive; Mechanic; Mechanically Operated Laser Screed; Mechanic Welder; Mucking Machine; Motor Scraper; Orangepeel Bucket; Overhead Crane; Piledriver; Power Blade; Pumpcrete; Push Dozer; Rock Spreader, attached to equipment; Rotary Drill; Roller (Bituminous); Rough Terrain Crane; Scarifier; Scoopmobile; Shovel; Side Boom; Subgrader; Tailboom;

Telescoping Type Forklift; Tow or Push Boat; Tower Crane (French, German & other types); Tractor Shovel; Truck Crane; Tunnel Mining Machines, including Moles, Shields or similar types of Tunnel Mining Equipment

GROUP 2 - Air Compressor (Over 900 cu. ft. per min.); Bituminous Mixer; Boom Type Tamping Machine; Bull Float; Concrete Mixer (Under 21 cu. ft.); Dredge Engineer; Electric Vibrator; Compactor/Self-Propelled Compactor; Elevator (One Drum or Buck Hoist); Elevator (When used to Hoist Building Material); Finish Machine; Firemen & Hoist (One Drum); Flexplane; Forklift (Regardless of Lift Height); Form Grader; Joint Sealing Machine; Outboard Motor Boat; Power Sweeper (Riding Type); Roller (Rock); Ross Carrier; Skid Mounted or Trailer Mounted Concrete Pump; Skid Steer Machine with all Attachments; Switchman or Brakeman; Throttle Valve Person; Tractair & Road Widening Trencher; Tractor (50 H.P. or Over); Truck Crane Oiler; Tugger; Welding Machine; Well Points; & Whirley Oiler

GROUP 3 - All Off Road Material Handling Equipment, including Articulating Dump Trucks; Greaser on Grease Facilities servicing Heavy Equipment

GROUP 4 - Bituminous Distributor; Burlap & Curing Machine; Cement Gun; Concrete Saw; Conveyor; Deckhand Oiler; Grout Pump; Hydraulic Post Driver; Hydro Seeder; Mud Jack; Oiler; Paving Joint Machine; Power Form Handling Equipment; Pump; Roller (Earth); Steerman; Tamping Machine; Tractor (Under 50 H.P.); & Vibrator

CRANES - with booms 150 ft. & Over (Including JIB), and where the length of the boom in combination with the length of the piling leads equals or exceeds 150 ft. - \$1.00 over Group 1 rate

EMPLOYEES ASSIGNED TO WORK BELOW GROUND LEVEL ARE TO BE PAID 10% ABOVE BASIC WAGE RATE. THIS DOES NOT APPLY TO OPEN CUT WORK.

IRON0044-009 06/01/2020

BRACKEN, GALLATIN, GRANT, HARRISON, ROBERTSON, BOURBON (Northern third, including Townships of Jackson, Millersburg, Ruddel Mills & Shawhan); CARROLL (Eastern third, including the Township of Ghent); FLEMING (Western part, excluding Townships of Beechburg, Colfax, Elizaville, Flemingsburg, Flemingsburg Junction, Foxport, Grange City, Hillsboro, Hilltop, Mount Carmel, Muses Mills, Nepton, Pecksridge, Plummers Landing, Plummers Mill, Poplar Plains, Ringos Mills, Tilton & Wallingford); MASON (Western two-thirds, including Townships of Dover, Lewisburg, Mays Lick, Maysville, Minerva, Moranburg, Murphysville, Ripley, Sardis, Shannon, South Ripley & Washington); NICHOLAS (Townships of Barefoot, Barterville, Carlisle, Ellisville, Headquarters, Henryville, Morningglory, Myers & Oakland Mills); OWEN (Townships of Beechwood, Bromley, Fairbanks, Holbrook, Jonesville, Long Ridge, Lusby's Mill, New, New Columbus, New Liberty, Owenton, Poplar Grove, Rockdale, Sanders, Teresita &

Wheatley);
SCOTT (Northern two-thirds, including Townships of Biddle,
Davis, Delaplain, Elmville, Longlick, Muddy Ford, Oxford,
Rogers Gap, Sadieville, Skinnersburg & Stonewall)

	Rates	Fringes
IRONWORKER		
Fence Erector.....	\$ 28.95	21.20
Structural.....	\$ 30.47	21.20

IRON0070-006 06/01/2020

ANDERSON, BOYLE, BRECKINRIDGE, BULLITT, FAYETTE, FRANKLIN,
GRAYSON, HARDIN, HENRY, JEFFERSON, JESSAMINE, LARUE, MADISON,
MARION, MEADE, MERCER, NELSON, OLDHAM, SHELBY, SPENCER,
TRIMBLE, WASHINGTON & WOODFORD
BOURBON (Southern two-thirds, including Townships of Austerlity,
Centerville, Clintonville, Elizabeth, Hutchison, Littlerock,
North Middletown & Paris);
CARROLL (Western two-thirds, including Townships of Carrollton,
Easterday, English, Locust, Louis, Prestonville & Worthville);
CLARK (Western two-thirds, including Townships of Becknerville,
Flanagan, Ford, Pine Grove, Winchester & Wyandotte);
OWEN (Eastern eighth, including Townships of Glenmary, Gratz,
Monterey, Perry Park & Tacketts Mill);
SCOTT (Southern third, including Townships of Georgetown, Great
Crossing, Newtown, Stampling Ground & Woodlake);

	Rates	Fringes
IRONWORKER.....	\$ 30.42	23.15

IRON0769-007 06/01/2020

BATH, BOYD, CARTER, ELLIOTT, GREENUP, LEWIS, MONTGOMERY & ROWAN
CLARK (Eastern third, including townships of Bloomingdale,
Hunt, Indian Fields, Kiddville, Loglick, Rightangele & Thomson);
FLEMING (Townships of Beechburg, Colfax, Elizaville,
Flemingsburg, Flemingsburg Junction, Foxport, Grange City,
Hillsboro, Hilltop, Mount Carmel, Muses Mills, Nepton,
Pecksridge, Plummers Landing, Plummers Mill, Poplar Plains,
Ringos Mills, Tilton & Wallingford);
MASON (Eastern third, including Townships of Helena, Marshall,
Orangeburg, Plumville & Springdale);
NICHOLAS (Eastern eighth, including the Township of Moorefield
Sprout)

	Rates	Fringes
IRONWORKER		
ZONE 1.....	\$ 32.75	26.34
ZONE 2.....	\$ 33.15	26.34
ZONE 3.....	\$ 34.75	26.34

ZONE 1 - (no base rate increase) Up to 10 mile radius of
Union Hall, 1643 Greenup Ave, Ashland, KY.

ZONE 2 - (add \$0.40 per hour to base rate) 10 to 50 mile

radius of Union Hall, 1643 Greenup Ave, Ashland, KY.

ZONE 3 - (add \$2.00 per hour to base rate) 50 mile radius & over of Union Hall, 1643 Greenup Ave, Ashland, KY.

LABO0189-003 07/01/2020

BATH, BOURBON, BOYD, BOYLE, BRACKEN, CARTER, CLARK, ELLIOTT, FAYETTE, FLEMING, FRANKLIN, GALLATIN, GRANT, GREENUP, HARRISON, JESSAMINE, LEWIS, MADISON, MASON, MERCER, MONTGOMERY, NICHOLAS, OWEN, ROBERTSON, ROWAN, SCOTT, & WOOLFORD COUNTIES

	Rates	Fringes
Laborers:		
GROUP 1.....	\$ 23.26	15.62
GROUP 2.....	\$ 23.56	15.62
GROUP 3.....	\$ 23.51	15.62
GROUP 4.....	\$ 24.16	15.62

LABORERS CLASSIFICATIONS

GROUP 1 - Aging & Curing of Concrete; Asbestos Abatement Worker; Asphalt Plant; Asphalt; Batch Truck Dump; Carpenter Tender; Cement Mason Tender; Cleaning of Machines; Concrete; Demolition; Dredging; Environmental - Nuclear, Radiation, Toxic & Hazardous Waste - Level D; Flagperson; Grade Checker; Hand Digging & Hand Back Filling; Highway Marker Placer; Landscaping, Mesh Handler & Placer; Puddler; Railroad; Rip-rap & Grouter; Right-of-Way; Sign, Guard Rail & Fence Installer; Signal Person; Sound Barrier Installer; Storm & Sanitary Sewer; Swamper; Truck Spotter & Dumper; Wrecking of Concrete Forms; General Cleanup

GROUP 2 - Batter Board Man (Sanitary & Storm Sewer); Brickmason Tender; Mortar Mixer Operator; Scaffold Builder; Burner & Welder; Bushhammer; Chain Saw Operator; Concrete Saw Operator; Deckhand Scow Man; Dry Cement Handler; Environmental - Nuclear, Radiation, Toxic & Hazardous Waste - Level C; Forklift Operator for Masonary; Form Setter; Green Concrete Cutting; Hand Operated Grouter & Grinder Machine Operator; Jackhammer; Pavement Breaker; Paving Joint Machine; Pipelayer; Plastic Pipe Fusion; Power Driven Georgia Buggy & Wheel Barrow; Power Post Hole Digger; Precast Manhole Setter; Walk-Behind Tamper; Walk-Behind Trencher; Sand Blaster; Concrete Chipper; Surface Grinder; Vibrator Operator; Wagon Driller

GROUP 3 - Asphalt Luteman & Raker; Gunnite Nozzleman; Gunnite Operator & Mixer; Grout Pump Operator; Side Rail Setter; Rail Paved Ditches; Screw Operator; Tunnel (Free Air); Water Blaster

GROUP 4 - Caisson Worker (Free Air); Cement Finisher; Environmental - Nuclear, Radiation, Toxic & Hazardous Waste - Levels A & B; Miner & Driller (Free Air); Tunnel Blaster; & Tunnel Mucker (Free Air); Directional & Horizontal Boring; Air Track Drillers (All Types); Powdermen & Blasters; Troxler & Concrete Tester if Laborer is Utilized

LABO0189-008 07/01/2020

ANDERSON, BULLITT, CARROLL, HARDIN, HENRY, JEFFERSON, LARUE,
MARION, MEADE, NELSON, OLDHAM, SHELBY, SPENCER, TRIMBLE &
WASHINGTON COUNTIES

	Rates	Fringes
Laborers:		
GROUP 1.....	\$ 23.26	15.62
GROUP 2.....	\$ 23.51	15.62
GROUP 3.....	\$ 23.56	15.62
GROUP 4.....	\$ 24.16	15.62

LABORERS CLASSIFICATIONS

GROUP 1 - Aging & Curing of Concrete; Asbestos Abatement Worker; Asphalt Plant; Asphalt; Batch Truck Dump; Carpenter Tender; Cement Mason Tender; Cleaning of Machines; Concrete; Demolition; Dredging; Environmental - Nuclear, Radiation, Toxic & Hazardous Waste - Level D; Flagperson; Grade Checker; Hand Digging & Hand Back Filling; Highway Marker Placer; Landscaping, Mesh Handler & Placer; Puddler; Railroad; Rip-rap & Grouter; Right-of-Way; Sign, Guard Rail & Fence Installer; Signal Person; Sound Barrier Installer; Storm & Sanitary Sewer; Swamper; Truck Spotter & Dumper; Wrecking of Concrete Forms; General Cleanup

GROUP 2 - Batter Board Man (Sanitary & Storm Sewer); Brickmason Tender; Mortar Mixer Operator; Scaffold Builder; Burner & Welder; Bushhammer; Chain Saw Operator; Concrete Saw Operator; Deckhand Scow Man; Dry Cement Handler; Environmental - Nuclear, Radiation, Toxic & Hazardous Waste - Level C; Forklift Operator for Masonary; Form Setter; Green Concrete Cutting; Hand Operated Grouter & Grinder Machine Operator; Jackhammer; Pavement Breaker; Paving Joint Machine; Pipelayer; Plastic Pipe Fusion; Power Driven Georgia Buggy & Wheel Barrow; Power Post Hole Digger; Precast Manhole Setter; Walk-Behind Tamper; Walk-Behind Trencher; Sand Blaster; Concrete Chipper; Surface Grinder; Vibrator Operator; Wagon Driller

GROUP 3 - Asphalt Luteman & Raker; Gunnite Nozzleman; Gunnite Operator & Mixer; Grout Pump Operator; Side Rail Setter; Rail Paved Ditches; Screw Operator; Tunnel (Free Air); Water Blaster

GROUP 4 - Caisson Worker (Free Air); Cement Finisher; Environmental - Nuclear, Radiation, Toxic & Hazardous Waste - Levels A & B; Miner & Driller (Free Air); Tunnel Blaster; & Tunnel Mucker (Free Air); Directional & Horizontal Boring; Air Track Drillers (All Types); Powdermen & Blasters; Troxler & Concrete Tester if Laborer is Utilized

LABO0189-009 07/01/2020

BRECKINRIDGE & GRAYSON COUNTIES

Rates Fringes

Laborers:

GROUP 1.....	\$ 23.26	15.62
GROUP 2.....	\$ 23.51	15.62
GROUP 3.....	\$ 23.56	15.62
GROUP 4.....	\$ 24.16	15.62

LABORERS CLASSIFICATIONS

GROUP 1 - Aging & Curing of Concrete; Asbestos Abatement Worker; Asphalt Plant; Asphalt; Batch Truck Dump; Carpenter Tender; Cement Mason Tender; Cleaning of Machines; Concrete; Demolition; Dredging; Environmental - Nuclear, Radiation, Toxic & Hazardous Waste - Level D; Flagperson; Grade Checker; Hand Digging & Hand Back Filling; Highway Marker Placer; Landscaping, Mesh Handler & Placer; Puddler; Railroad; Rip-rap & Grouter; Right-of-Way; Sign, Guard Rail & Fence Installer; Signal Person; Sound Barrier Installer; Storm & Sanitary Sewer; Swamper; Truck Spotter & Dumper; Wrecking of Concrete Forms; General Cleanup

GROUP 2 - Batter Board Man (Sanitary & Storm Sewer); Brickmason Tender; Mortar Mixer Operator; Scaffold Builder; Burner & Welder; Bushhammer; Chain Saw Operator; Concrete Saw Operator; Deckhand Scow Man; Dry Cement Handler; Environmental - Nuclear, Radiation, Toxic & Hazardous Waste - Level C; Forklift Operator for Masonary; Form Setter; Green Concrete Cutting; Hand Operated Grouter & Grinder Machine Operator; Jackhammer; Pavement Breaker; Paving Joint Machine; Pipelayer; Plastic Pipe Fusion; Power Driven Georgia Buggy & Wheel Barrow; Power Post Hole Digger; Precast Manhole Setter; Walk-Behind Tamper; Walk-Behind Trencher; Sand Blaster; Concrete Chipper; Surface Grinder; Vibrator Operator; Wagon Driller

GROUP 3 - Asphalt Luteman & Raker; Gunnite Nozzleman; Gunnite Operator & Mixer; Grout Pump Operator; Side Rail Setter; Rail Paved Ditches; Screw Operator; Tunnel (Free Air); Water Blaster

GROUP 4 - Caisson Worker (Free Air); Cement Finisher; Environmental - Nuclear, Radiation, Toxic & Hazardous Waste - Levels A & B; Miner & Driller (Free Air); Tunnel Blaster; & Tunnel Mucker (Free Air); Directional & Horizontal Boring; Air Track Drillers (All Types); Powdermen & Blasters; Troxler & Concrete Tester if Laborer is Utilized

PAIN0012-005 06/11/2005

BATH, BOURBON, BOYLE, CLARK, FAYETTE, FLEMING, FRANKLIN, HARRISON, JESSAMINE, MADISON, MERCER, MONTGOMERY, NICHOLAS, ROBERTSON, SCOTT & WOODFORD COUNTIES:

Rates Fringes

PAINTER

Bridge/Equipment Tender and/or Containment Builder..	\$ 18.90	5.90
Brush & Roller.....	\$ 21.30	5.90
Elevated Tanks;		

Steeplejack Work; Bridge & Lead Abatement.....	\$ 22.30	5.90
Sandblasting & Waterblasting.....	\$ 22.05	5.90
Spray.....	\$ 21.80	5.90

PAIN0012-017 05/01/2015

BRACKEN, GALLATIN, GRANT, MASON & OWEN COUNTIES:

	Rates	Fringes
PAINTER (Heavy & Highway Bridges - Guardrails - Lightpoles - Striping)		
Bridge Equipment Tender and Containment Builder.....	\$ 20.73	9.06
Brush & Roller.....	\$ 23.39	9.06
Elevated Tanks; Steeplejack Work; Bridge & Lead Abatement.....		
Sandblasting & Water Blasting.....	\$ 24.39	9.06
Spray.....	\$ 24.14	9.06
	\$ 23.89	9.06

PAIN0118-004 06/01/2018

ANDERSON, BRECKINRIDGE, BULLITT, CARROLL, GRAYSON, HARDIN, HENRY, JEFFERSON, LARUE, MARION, MEADE, NELSON, OLDHAM, SHELBY, SPENCER, TRIMBLE & WASHINGTON COUNTIES:

	Rates	Fringes
PAINTER		
Brush & Roller.....	\$ 22.00	12.52
Spray, Sandblast, Power Tools, Waterblast & Steam Cleaning.....	\$ 23.00	12.52

PAIN1072-003 12/01/2018

BOYD, CARTER, ELLIOTT, GREENUP, LEWIS and ROWAN COUNTIES

	Rates	Fringes
Painters:		
Bridges; Locks; Dams; Tension Towers & Energized Substations.....		
Power Generating Facilities.....	\$ 33.33	18.50
	\$ 30.09	18.50

PLUM0248-003 06/01/2020

BOYD, CARTER, ELLIOTT, GREENUP, LEWIS & ROWAN COUNTIES:

	Rates	Fringes
Plumber and Steamfitter.....	\$ 37.05	21.48

PLUM0392-007 06/01/2018

BRACKEN, CARROLL (Eastern Half), GALLATIN, GRANT, MASON, OWEN &
ROBERTSON COUNTIES:

	Rates	Fringes
Plumbers and Pipefitters.....	\$ 32.01	19.67

PLUM0502-003 08/01/2020		

BRECKINRIDGE, BULLITT, CARROLL (Western Half), FRANKLIN
(Western three-fourths), GRAYSON, HARDIN, HENRY, JEFFERSON,
LARUE, MARION, MEADE, NELSON, OLDHAM, SHELBY, SPENCER, TRIMBLE &
WASHINGTON COUNTIES

	Rates	Fringes
PLUMBER.....	\$ 36.92	20.78

SUKY2010-160 10/08/2001		

	Rates	Fringes
Truck drivers:		
GROUP 1.....	\$ 16.57	7.34
GROUP 2.....	\$ 16.68	7.34
GROUP 3.....	\$ 16.86	7.34
GROUP 4.....	\$ 16.96	7.34

TRUCK DRIVER CLASSIFICATIONS

GROUP 1 - Mobile Batch Truck Tender

GROUP 2 - Greaser; Tire Changer; & Mechanic Tender

GROUP 3 - Single Axle Dump; Flatbed; Semi-trailer or Pole
Trailer when used to pull building materials and equipment;
Tandem Axle Dump; Distributor; Mixer; & Truck Mechanic

GROUP 4 - Euclid & Other Heavy Earthmoving Equipment &
Lowboy; Articulator Cat; 5-Axle Vehicle; Winch & A-Frame
when used in transporting materials; Ross Carrier; Forklift
when used to transport building materials; & Pavement
Breaker

WELDERS - Receive rate prescribed for craft performing
operation to which welding is incidental.

=====
Note: Executive Order (EO) 13706, Establishing Paid Sick Leave
for Federal Contractors applies to all contracts subject to the
Davis-Bacon Act for which the contract is awarded (and any
solicitation was issued) on or after January 1, 2017. If this
contract is covered by the EO, the contractor must provide
employees with 1 hour of paid sick leave for every 30 hours
they work, up to 56 hours of paid sick leave each year.
Employees must be permitted to use paid sick leave for their
own illness, injury or other health-related needs, including

preventive care; to assist a family member (or person who is like family to the employee) who is ill, injured, or has other health-related needs, including preventive care; or for reasons resulting from, or to assist a family member (or person who is like family to the employee) who is a victim of, domestic violence, sexual assault, or stalking. Additional information on contractor requirements and worker protections under the EO is available at www.dol.gov/whd/govcontracts.

Unlisted classifications needed for work not included within the scope of the classifications listed may be added after award only as provided in the labor standards contract clauses (29CFR 5.5 (a) (1) (ii)).

The body of each wage determination lists the classification and wage rates that have been found to be prevailing for the cited type(s) of construction in the area covered by the wage determination. The classifications are listed in alphabetical order of ""identifiers"" that indicate whether the particular rate is a union rate (current union negotiated rate for local), a survey rate (weighted average rate) or a union average rate (weighted union average rate).

Union Rate Identifiers

A four letter classification abbreviation identifier enclosed in dotted lines beginning with characters other than ""SU"" or ""UAVG"" denotes that the union classification and rate were prevailing for that classification in the survey. Example: PLUM0198-005 07/01/2014. PLUM is an abbreviation identifier of the union which prevailed in the survey for this classification, which in this example would be Plumbers. 0198 indicates the local union number or district council number where applicable, i.e., Plumbers Local 0198. The next number, 005 in the example, is an internal number used in processing the wage determination. 07/01/2014 is the effective date of the most current negotiated rate, which in this example is July 1, 2014.

Union prevailing wage rates are updated to reflect all rate changes in the collective bargaining agreement (CBA) governing this classification and rate.

Survey Rate Identifiers

Classifications listed under the ""SU"" identifier indicate that no one rate prevailed for this classification in the survey and the published rate is derived by computing a weighted average rate based on all the rates reported in the survey for that classification. As this weighted average rate includes all rates reported in the survey, it may include both union and non-union rates. Example: SULA2012-007 5/13/2014. SU indicates the rates are survey rates based on a weighted average calculation of rates and are not majority rates. LA indicates the State of Louisiana. 2012 is the year of survey on which these classifications and rates are based. The next number, 007 in the example, is an internal number used in producing the wage determination. 5/13/2014 indicates the survey completion

date for the classifications and rates under that identifier.

Survey wage rates are not updated and remain in effect until a new survey is conducted.

Union Average Rate Identifiers

Classification(s) listed under the UAVG identifier indicate that no single majority rate prevailed for those classifications; however, 100% of the data reported for the classifications was union data. EXAMPLE: UAVG-OH-0010 08/29/2014. UAVG indicates that the rate is a weighted union average rate. OH indicates the state. The next number, 0010 in the example, is an internal number used in producing the wage determination. 08/29/2014 indicates the survey completion date for the classifications and rates under that identifier.

A UAVG rate will be updated once a year, usually in January of each year, to reflect a weighted average of the current negotiated/CBA rate of the union locals from which the rate is based.

WAGE DETERMINATION APPEALS PROCESS

1.) Has there been an initial decision in the matter? This can be:

- * an existing published wage determination
- * a survey underlying a wage determination
- * a Wage and Hour Division letter setting forth a position on a wage determination matter
- * a conformance (additional classification and rate) ruling

On survey related matters, initial contact, including requests for summaries of surveys, should be with the Wage and Hour Regional Office for the area in which the survey was conducted because those Regional Offices have responsibility for the Davis-Bacon survey program. If the response from this initial contact is not satisfactory, then the process described in 2.) and 3.) should be followed.

With regard to any other matter not yet ripe for the formal process described here, initial contact should be with the Branch of Construction Wage Determinations. Write to:

Branch of Construction Wage Determinations
Wage and Hour Division
U.S. Department of Labor
200 Constitution Avenue, N.W.
Washington, DC 20210

2.) If the answer to the question in 1.) is yes, then an interested party (those affected by the action) can request review and reconsideration from the Wage and Hour Administrator (See 29 CFR Part 1.8 and 29 CFR Part 7). Write to:

Wage and Hour Administrator
U.S. Department of Labor

200 Constitution Avenue, N.W.
Washington, DC 20210

The request should be accompanied by a full statement of the interested party's position and by any information (wage payment data, project description, area practice material, etc.) that the requestor considers relevant to the issue.

3.) If the decision of the Administrator is not favorable, an interested party may appeal directly to the Administrative Review Board (formerly the Wage Appeals Board). Write to:

Administrative Review Board
U.S. Department of Labor
200 Constitution Avenue, N.W.
Washington, DC 20210

4.) All decisions by the Administrative Review Board are final.

=====

END OF GENERAL DECISION

"

Fringe benefit amounts are applicable for all hours worked except when otherwise noted.

No laborer, workman or mechanic shall be paid at a rate less than that of a Journeyman except those classified as bona fide apprentices.

Apprentices or trainees shall be permitted to work as such subject to Administrative Regulations adopted by the Commissioner of Workplace Standards. Copies of these regulations will be furnished upon request from any interested person.

Before using apprentices on the job the contractor shall present to the Contracting Officer written evidence of registration of such employees in a program of a State apprenticeship and training agency approved and recognized by the U. S. Bureau of Apprenticeship and Training. In the absence of such a State agency, the contractor shall submit evidence of approval and registration by the U. S. Bureau of Apprenticeship and Training.

The contractor shall submit to the Contracting Officer, written evidence of the established apprenticeship-journeyman ratios and wage rates in the project area, which will be the basis for establishing such ratios and rates for the project under the applicable contract provisions.

TO: EMPLOYERS/EMPLOYEES

PREVAILING WAGE SCHEDULE:

The wages indicated on this wage schedule are the least permitted to be paid for the occupations indicated. When an employee works in more than one classification, the employer must record the number of hours worked in each classification at the prescribed hourly base rate.

OVERTIME:

Overtime is to be paid to an employee at a rate not less than one and one-half times the basic rate of pay for all hours worked in excess of forty (40) hours in such workweek. Wage violations or questions should be directed to the designated Engineer or the undersigned.

Director
Division of Construction Procurement
Frankfort, Kentucky 40622
502-564-3500

**NOTICE OF REQUIREMENT FOR AFFIRMATIVE ACTION
TO ENSURE EQUAL EMPLOYMENT OPPORTUNITY
(Executive Order 11246)**

1. The Offeror's or Bidder's attention is called to the "Equal Opportunity Clause" and the "Standard Federal Equal Employment Specifications" set forth herein.
2. The goals and timetables for minority and female participation, expressed in percentage terms for the Contractor's aggregate work force in each trade on all construction work in the covered area, are as follows:

GOALS FOR MINORITY PARTICIPATION IN EACH TRADE	GOALS FOR FEMALE PARTICIPATION IN EACH TRADE
11.0%	6.9%

These goals are applicable to all the Contractor's construction work (whether or not it is Federal or federally-assisted) performed in the covered area. If the contractor performs construction work in a geographical area located outside of the covered area, it shall apply the goals established for such geographical area where the work is actually performed. With regard to this second area, the contractor also is subject to the goals for both its federally involved and non-federally involved construction.

The Contractor's compliance with the Executive Order and the regulations in CFR Part 60-4 shall be based on its implementation of the Equal Opportunity Clause, specific affirmative action obligations required by the specifications set forth in 41 CFR 60-4, 3(a), and its efforts to meet the goals. The hours of minority and female employment and training must be substantially uniform throughout the length of the contract, and in each trade, and the contractor shall make a good faith effort to employ minorities and women evenly on each of its projects. The transfer of minority or female employees or trainees from Contractor to Contractor or from project to project for the sole purpose of meeting the Contractor's goals shall be a violation of the contract, the Executive Order and the regulations in 41 CFR Part 60-4. Compliance with the goals will be measured against the total work hours performed.

3. The Contractor shall provide written notification to the Director of the Office of Federal Contract Compliance Programs within ten (10) working days of award of any construction subcontract in excess of \$10,000.00 at any tier for construction work under the contract resulting from this solicitation. The notification shall list the name, address and telephone number of the subcontractor; employer identification number of the subcontractor; estimated dollar amount of the subcontract; estimated starting and completion dates of the subcontract; and the geographical area in which the subcontract is to be performed. The notification shall be mailed to:

**Evelyn Teague, Regional Director
Office of Federal Contract Compliance Programs
61 Forsyth Street, SW, Suite 7B75
Atlanta, Georgia 30303-8609**

4. As used in this Notice, and in the contract resulting from this solicitation, the "**covered area**" is Kenton County.

PART IV
INSURANCE

Refer to
Kentucky Standard Specifications for Road and Bridge Construction,
current edition

PART V
BID ITEMS

PROPOSAL BID ITEMS

212955

Page 1 of 1

Report Date 1/6/21

Section: 0001 - BRIDGES - KENTUCKY APPROACH

LINE	BID CODE	ALT	DESCRIPTION	QUANTITY	UNIT	UNIT PRIC	FP	AMOUNT
0010	02650		MAINTAIN & CONTROL TRAFFIC - 059B00040N	1.00	LS		\$	
0020	02671		PORTABLE CHANGEABLE MESSAGE SIGN - 059B00040N	2.00	EACH		\$	
0030	08434		CLEAN & PAINT STRUCTURAL STEEL - 059B00040N	1.00	LS		\$	

Section: 0002 - BRIDGES - MAIN RIVER TRUSS

LINE	BID CODE	ALT	DESCRIPTION	QUANTITY	UNIT	UNIT PRIC	FP	AMOUNT
0040	02650		MAINTAIN & CONTROL TRAFFIC - 056B00046N	1.00	LS		\$	
0050	02671		PORTABLE CHANGEABLE MESSAGE SIGN - 059B00046N	2.00	EACH		\$	
0060	06405		SBM ALUMINUM PANEL SIGNS - 059B00046N	540.00	SQFT		\$	
0070	08434		CLEAN & PAINT STRUCTURAL STEEL - 059B00046N	1.00	LS		\$	
0080	23378EC		CONCRETE SEALING - 059B00046N	3,000.00	SQFT		\$	
0090	24692EC		DECK DRAIN RETROFIT - 059B00046N	1.00	EACH		\$	
0100	24899EC		PAVE MARKING-THERMO ELONG ROUTE SHIELD - 059B00046N	16.00	EACH		\$	

Section: 0003 - BRIDGES - OHIO APPROACH

LINE	BID CODE	ALT	DESCRIPTION	QUANTITY	UNIT	UNIT PRIC	FP	AMOUNT
0110	02650		MAINTAIN & CONTROL TRAFFIC - 059B00046N	1.00	LS		\$	
0120	02671		PORTABLE CHANGEABLE MESSAGE SIGN - 059B00046N	2.00	EACH		\$	
0130	08434		CLEAN & PAINT STRUCTURAL STEEL - 059B00046N	1.00	LS		\$	
0140	26118EC		REPLACE TRAFFIC PROTECTION - 059B00046N	31,900.00	SQFT		\$	

Section: 0004 - DEMOB

LINE	BID CODE	ALT	DESCRIPTION	QUANTITY	UNIT	UNIT PRIC	FP	AMOUNT
0150	02568		MOBILIZATION	1.00	LS		\$	
0160	02569		DEMOBILIZATION	1.00	LS		\$	