

High-Performance DrMOS

6 mm x 6 mm x 0.8 mm IQFN

TDA21220

Data Sheet

Revision 1.9, 2011-03-31
Preliminary

Industry and Multi Market

Edition 2011-03-31

**Published by
Infineon Technologies AG
81726 Munich, Germany**

**© 2011 Infineon Technologies AG
All Rights Reserved.**

Legal Disclaimer

The information given in this document shall in no event be regarded as a guarantee of conditions or characteristics. With respect to any examples or hints given herein, any typical values stated herein and/or any information regarding the application of the device, Infineon Technologies hereby disclaims any and all warranties and liabilities of any kind, including without limitation, warranties of non-infringement of intellectual property rights of any third party.

Information

For further information on technology, delivery terms and conditions and prices, please contact the nearest Infineon Technologies Office (www.infineon.com).

Warnings

Due to technical requirements, components may contain dangerous substances. For information on the types in question, please contact the nearest Infineon Technologies Office.

Infineon Technologies components may be used in life-support devices or systems only with the express written approval of Infineon Technologies, if a failure of such components can reasonably be expected to cause the failure of that life-support device or system or to affect the safety or effectiveness of that device or system. Life support devices or systems are intended to be implanted in the human body or to support and/or maintain and sustain and/or protect human life. If they fail, it is reasonable to assume that the health of the user or other persons may be endangered.

Revision History

Page or Item	Subjects (major changes since previous revision)
Revision 1.9, 2011-03-31	
All	Update format of document.
Table 6	Define the AC values.
Figure 1	Update the package picture
Table 14	Correct a typo on logic function of SMOD pin
Figure 9	Clarify the definition of T_GHtsshd and T_GLtsshd
Table 11	Update the Toff_min_PWM to min 65ns

Trademarks of Infineon Technologies AG

AURIX™, BlueMoon™, C166™, CanPAK™, CIPOS™, CIPURSE™, COMNEON™, EconoPACK™, CoolMOS™, CoolSET™, CORECONTROL™, CROSSAVE™, DAVE™, EasyPIM™, EconoBRIDGE™, EconoDUAL™, EconoPIM™, EiceDRIVER™, eupec™, FCOS™, HITFET™, HybridPACK™, I²RF™, ISOFACE™, IsoPACK™, MIPAQ™, ModSTACK™, my-d™, NovalithIC™, OmniTune™, OptiMOS™, ORIGA™, PRIMARION™, PrimePACK™, PrimeSTACK™, PRO-SIL™, PROFET™, RASIC™, ReverSave™, SatRIC™, SIEGET™, SINDRION™, SIPMOS™, SMARTi™, SmartLEWIS™, SOLID FLASH™, TEMPFET™, thinQ!™, TRENCHSTOP™, TriCore™, X-GOLD™, X-PMU™, XMM™, XPOSYS™.

Other Trademarks

Advance Design System™ (ADS) of Agilent Technologies, AMBA™, ARM™, MULTI-ICE™, KEIL™, PRIMECELL™, REALVIEW™, THUMB™, μVision™ of ARM Limited, UK. AUTOSAR™ is licensed by AUTOSAR development partnership. Bluetooth™ of Bluetooth SIG Inc. CAT-iq™ of DECT Forum. COLOSSUS™, FirstGPS™ of Trimble Navigation Ltd. EMV™ of EMVCo, LLC (Visa Holdings Inc.). EPCOS™ of Epcos AG. FLEXGO™ of Microsoft Corporation. FlexRay™ is licensed by FlexRay Consortium. HYPERTERMINAL™ of Hilgraeve Incorporated. IEC™ of Commission Electrotechnique Internationale. IrDA™ of Infrared Data Association Corporation. ISO™ of INTERNATIONAL ORGANIZATION FOR STANDARDIZATION. MATLAB™ of MathWorks, Inc. MAXIM™ of Maxim Integrated Products, Inc. MICROTEC™, NUCLEUS™ of Mentor Graphics Corporation. Mifare™ of NXP. MIPI™ of MIPI Alliance, Inc. MIPS™ of MIPS Technologies, Inc., USA. muRata™ of MURATA MANUFACTURING CO., MICROWAVE OFFICE™ (MWO) of Applied Wave Research Inc., OmniVision™ of OmniVision Technologies, Inc. Openwave™ Openwave Systems Inc. RED HAT™ Red Hat, Inc. RFMD™ RF Micro Devices, Inc. SIRIUS™ of Sirius Satellite Radio Inc. SOLARIS™ of Sun Microsystems, Inc. SPANSION™ of Spansion LLC Ltd. Symbian™ of Symbian Software Limited. TAIYO YUDEN™ of Taiyo Yuden Co. TEAKLITE™ of CEVA, Inc. TEKTRONIX™ of Tektronix Inc. TOKO™ of TOKO KABUSHIKI KAISHA TA. UNIX™ of X/Open Company Limited. VERILOG™, PALLADIUM™ of Cadence Design Systems, Inc. VLYNQ™ of Texas Instruments Incorporated. VXWORKS™, WIND RIVER™ of WIND RIVER SYSTEMS, INC. ZETEX™ of Diodes Zetex Limited.

Last Trademarks Update 2010-10-26

1 Applications

- Desktop and Server VR11.X and VR12 Vcore and non-Vcore buck-converter
- Network and Telecom processor VR
- Single Phase and Multiphase POL
- CPU/GPU Regulation in Notebook, Desktop Graphics Cards, DDR Memory, Graphic Memory
- High Power Density Voltage Regulator Modules (VRM).

2 Features

- Compliant to Intel® VR12 Driver and Mosfets Module (DrMOS) for Desktop/Server Applications
- For synchronous Buck step down voltage applications
- Maximum average current of 50 A
- Input voltage range +4.5 V to +16 V
- Power MOSFETs rated 25 V for safe operation under all conditions
- Extremely fast switching technology for improved performance at high switching frequencies (> 1 MHz)
- Remote driver disable function
- Switch modulation (SMOD#) of low side MOSFET
- Includes bootstrap diode
- Shoot through protection
- +5 V High and Low Side driving voltage
- Compatible to standard +3.3 V PWM controller integrated circuits
- Three-state PWM input functionality
- Small package: IQFN40 (6 x 6 x 0.8 mm³)
- RoHS compliant

Table 1 Product Identification

Part Number	Temp Range	Package	Marking
TDA21220	-25 to 125°C	6 x 6 x 0.8 mm ³ PG-IQFN-40-1	TDA21220

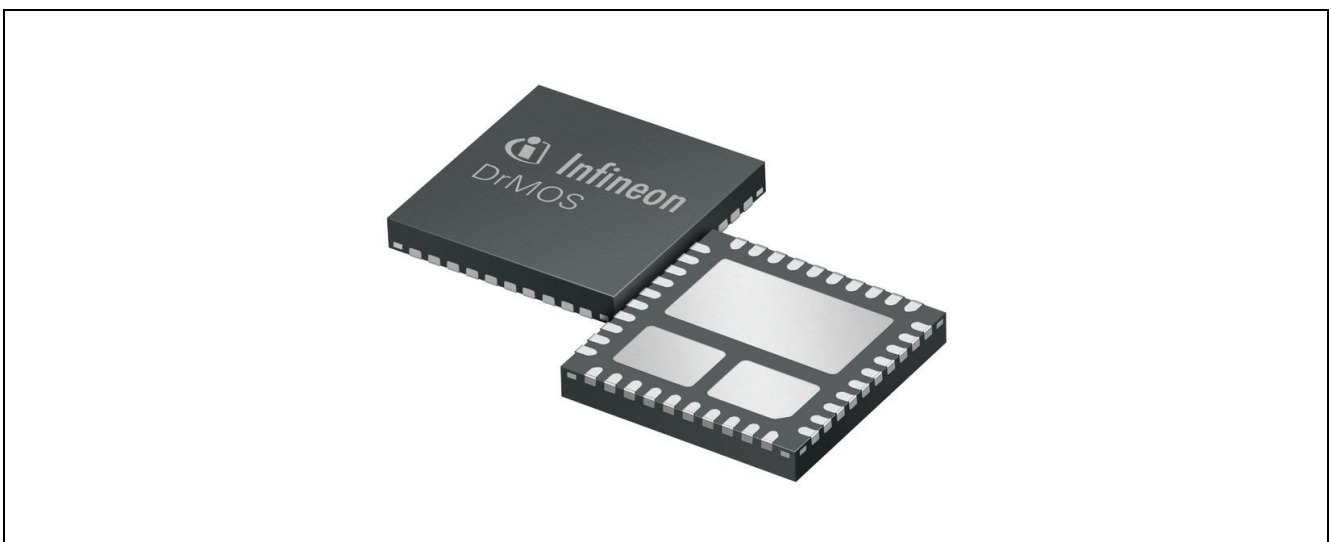

Figure 1 Picture of the Product

3 Description

3.1 Pinout

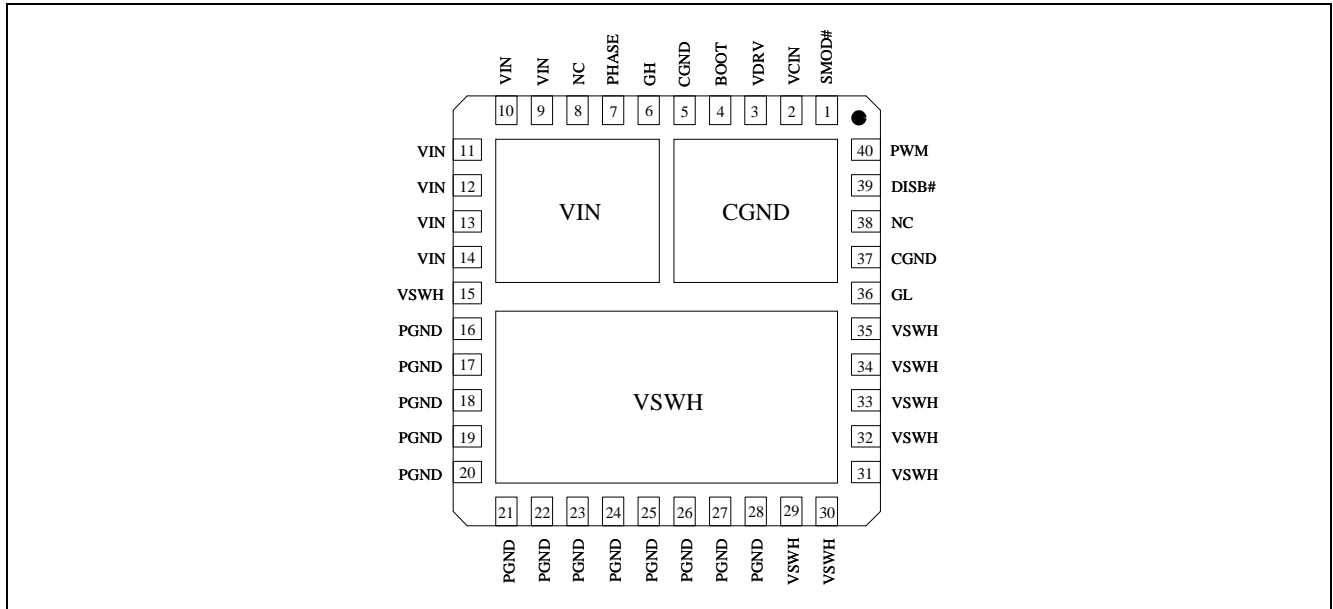

Figure 2 Pinout, Numbering and Name of Pins (transparent top view)

Note: Signals marked with “#” at the end are active low signals.

Table 2 I/O Signals

Pin No.	Name	Pin Type	Buffer Type	Function
1	SMOD#	I	+3.3 V logic	High and Low Side gate disable When SMOD# is “low” the GL is “off”
6	GH	O	Analog	High side gate signal Monitoring of High Side MOSFET gate
7	PHASE	O	Analog	Switch node output Internally connected to VSWH pin, Connect to BOOT capacitor
4	BOOT	I	Analog	Bootstrap voltage pin Connect to BOOT capacitor
15, 29 to 35, VSWH pad	VSWH	O	Analog	Switch node output High current output switching node
36	GL	O	Analog	Low side gate signal Monitoring of Low Side MOSFET gate
39	DISB#	I	+3.3 V logic	Disable signal (active low) Pull to GND to disable the IC.
40	PWM	I	+3.3 V logic	PWM drive logic input The three state PWM input is compatible with 3.3 V.

Table 3 Power Supply

Pin No.	Name	Pin Type	Buffer Type	Function
2	VCIN	POWER	–	Logic supply voltage 5 V bias voltage for the internal logic
3	VDRV	POWER	–	FET gate supply voltage High and Low Side gate drive 5 V supply
9 to 14, Vin pad	VIN	POWER	–	Input voltage Supply of the drain of the High Side MOSFET

Table 4 Ground Pins

Pin No.	Name	Pin Type	Buffer Type	Function
5, 37, CGND pad	CGND	GND	–	Control signal ground Should be connected to PGND externally
16 to 28	PGND	GND	–	Power ground All these pins must be connected to the power GND plane through multiple low inductance vias.

Table 5 Not Connected

Pin No.	Name	Pin Type	Buffer Type	Function
8, 38	NC	–	–	No internal connection Leave pin floating or tie to GND.

3.2 General Description

The Infineon TDA21220 is a multichip module that incorporates Infineon's premier MOSFET technology for a single high side and a single low side MOSFET coupled with a robust, high performance, high switching frequency gate driver in a single 40 pin QFN package. The optimized gate timing allows for significant light load efficiency improvements over discrete solutions. State of the art MOSFET technology provides exceptional full load performance. Thus this device has a clear advantage over existing approaches in the marketplace when both full load and light load efficiencies are important.

When combined with the Infineon's Primarion™ Controller Family of Digital Multi-phase Controllers, the TDA21220 forms a complete core-voltage regulator solution for advanced micro and graphics processors as well as point-of-load applications.

The TDA21220 is pin to pin compatible and compliant with the Intel 6x6 DrMOS specification. The device package height is only 0.8 mm, and is an excellent choice for applications with critical height limitations.

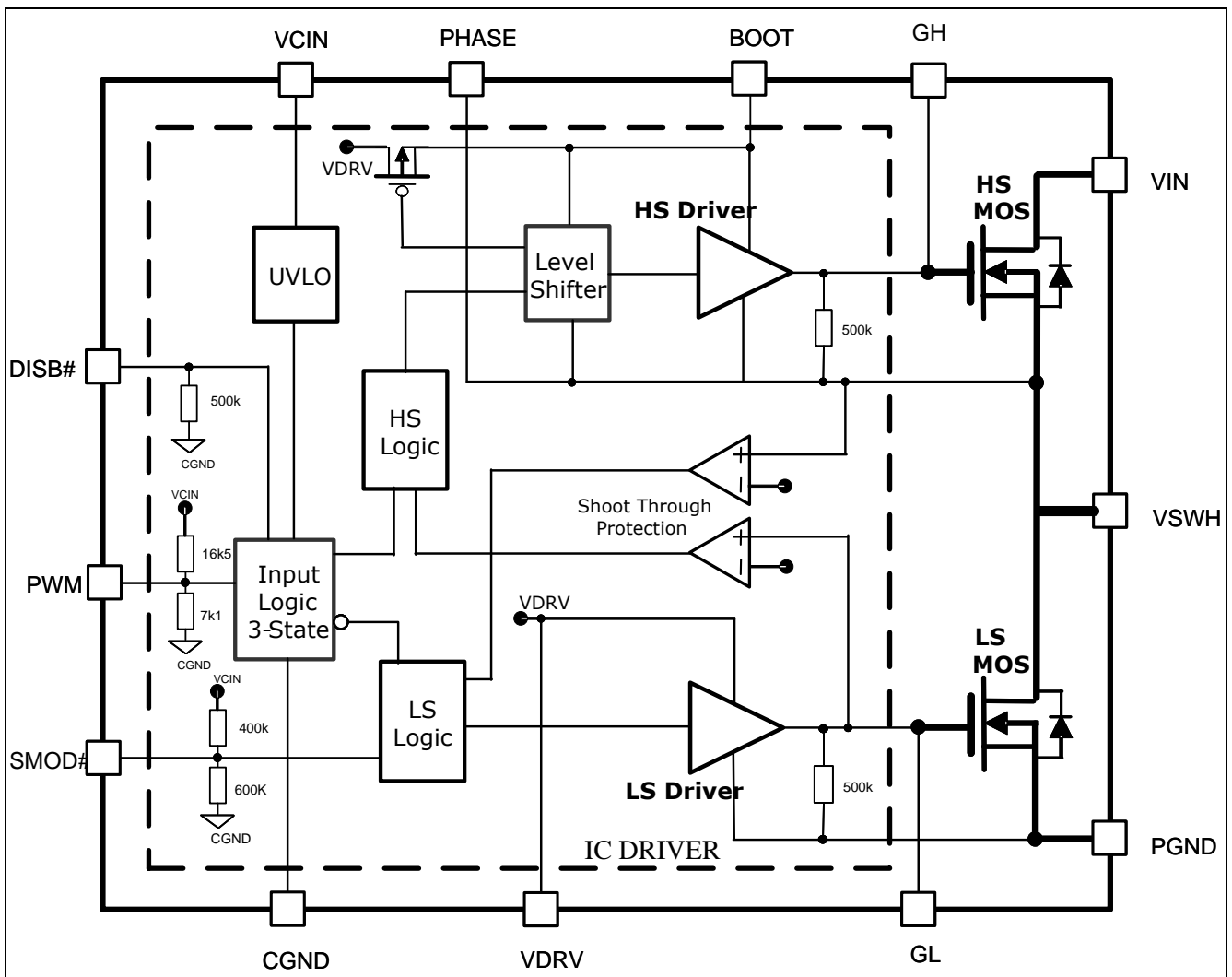

Figure 3 Simplified Block Diagram

4 Electrical Specification

4.1 Absolute Maximum Ratings

Note: $T_A = 25^\circ\text{C}$

Stresses above those listed in **Table 6** “Absolute Maximum Ratings” may cause permanent damage to the device. These are absolute stress ratings only and operation of the device is not implied or recommended at these or any other conditions in excess of those given in the operational sections of this specification. Exposure to the absolute maximum ratings for extended periods may adversely affect the operation and reliability of the device.

Table 6 Absolute Maximum Ratings

Parameter	Symbol	Values			Unit	Note / Test Condition
		Min.	Typ.	Max.		
Frequency of the PWM input	f_{SW}	–	–	1.2	MHz	–
Maximum average load current	I_{OUT}	–	–	50	A	–
Input Voltage	V_{IN} (DC)	-0.30	–	25	V	–
Logic supply voltage	V_{CIN} (DC)	-0.30	–	6.5	V	–
High and Low side driver voltage	V_{DRV} (DC)	-0.30	–	6.5	V	–
Switch node voltage	V_{SWH} (DC)	-1	–	25	V	–
	V_{SWH} (AC)	-10 ¹	–	25	V	–
PHASE node voltage	V_{PHASE} (DC)	-1	–	25	V	–
	V_{PHASE} (AC)	-10	–	25	V	–
BOOT voltage	V_{BOOT} (DC)	-0.3	–	31.5	V	–
	V_{BOOT} (AC)	-1 ¹	–	31.5	V	–
	$V_{\text{BOOT-PHASE}}$ (DC)	-1	–	6.5	V	–
SMOD# voltage	$V_{\text{SMOD\#}}$ (DC)	-0.3	–	5.5	V	–
DISB# voltage	V_{DISB} ²	-0.3	–	5.5	V	–
PWM voltage	V_{PWM} ²	-0.3	–	5.5	V	–
Junction temperature	T_{Jmax}	-40	–	150	°C	–
Storage temperature	T_{STG}	-55	–	150	°C	–

Note: All rated voltages are relative to voltages on the CGND and PGND pins unless otherwise specified.

¹ AC is limited to 10 ns

² Latch Up class II- Level B (Jedec 78). Please refer to Quality Report for details.

4.2 Thermal Characteristics

Table 7 Thermal Characteristics

Parameter	Symbol	Values			Unit	Note / Test Condition
		Min.	Typ.	Max.		
Thermal resistance, junction-soldering point ¹	θ_{JS}	–	5	–	K/W	–
Thermal resistance, junction-top of package	θ_{Jtop}	–	20	–		–

4.3 Recommended Operating Conditions and Electrical Characteristics

Note: $V_{DRV} = V_{CIN} = 5\text{ V}$, $T_A t = 25^\circ\text{C}$

Table 8 Recommended Operating Conditions

Parameter	Symbol	Values			Unit	Note / Test Condition
		Min.	Typ.	Max.		
Input voltage	V_{IN}	5	–	16	V	–
MOSFET driver voltage	V_{DRV}	4.5	5	6		–
Logic supply voltage	V_{CIN}	4.5	5	6		–
Junction temperature	T_{jOP}	-25	–	+125	°C	–

Table 9 Voltage Supply And Biasing Current

Parameter	Symbol	Values			Unit	Note / Test Condition
		Min.	Typ.	Max.		
Driver current	I_{VDRV_300kHz}	–	10	–	mA	DISB# = 5 V, $f_{sw} = 300\text{ kHz}$
	I_{VDRV_PWML}	–	25	–	µA	DISB# = 5 V, PWM = 0 V
IC current (control)	I_{VCIN_PWML}	–	400	–		DISB# = 5 V, PWM = 0 V SMOD# = Open
	I_{VCIN_O}	–	500	–		DISB# = 5 V, PWM = Open SMOD# = Open
IC quiescent	$I_{CIN} + I_{DRV}$	–	–	550		DISB# = 0 V
UVLO rising	V_{UVLO_R}	2.9	3.5	3.9	V	VCIN rising
UVLO falling	V_{UVLO_F}	2.5	3.1	3.3		VCIN falling

¹ The junction-soldering point is referred to the VSWH bottom exposed pad.

Table 10 Logic Inputs And Threshold

Parameter		Symbol	Values			Unit	Note / Test Condition
			Min.	Typ.	Max.		
DISB#	Input low	V_{DISB_L}	0.7	1.1	1.3	V	V_{DISB} falling
	Input high	V_{DISB_H}	1.9	2.1	2.4		V_{DISB} rising
	Sink current	I_{DISB}	–	2	–	μA	$V_{DISB} = 1 V$
SMOD#	Input low	$V_{SMOD\#_L}$	0.7	1.1	1.3	V	$V_{SMOD\#}$ falling
	Input high	$V_{SMOD\#_H}$	1.9	2.1	2.4		$V_{SMOD\#}$ rising
	Open voltage	$V_{SMOD\#_O}$	–	3.0	–		–
	Sink current	$I_{SMOD\#}$	–	-8	–	μA	$V_{SMOD\#} = 1 V$
PWM	Input low	V_{PWM_L}	–	–	0.7	V	V_{PWM} falling
	Input high	V_{PWM_H}	2.4	–	–		V_{PWM} rising
	Input resistance	R_{IN-PWM}	3	5	7	$k\Omega$	$V_{PWM} = 1 V$
	Open voltage	V_{PWM_O}	–	1.5	–	V	V_{PWM_O}
	Tristate shutdown window ¹	V_{PWM_S}	1.2	–	1.9		–

Table 11 Timing Characteristics

Parameter		Symbol	Values			Unit	Note / Test Condition
			Min.	Typ.	Max.		
Three State to GL/GH rising delay	T_{pts}	–	15	–	ns	GH, GL unloaded	
GL Shutdown Hold-Off time	T_{GLtssh}	–	150	–			
GH Shutdown Hold-Off time	T_{GHtssh}	–	85	–			
GH Turn-on propagation delay	T_{pdhu}	–	15	–			
GH Turn-off propagation delay	T_{pdlu}	–	20	–			
GL Turn-on propagation delay	T_{pdhl}	–	20	–			
GL Turn-off propagation delay	T_{pdll}	–	10	–			
DISB# Turn-off propagation delay falling	T_{pdl_DISB}	–	20	–			
DISB# Turn-on propagation delay rising	T_{pdh_DISB}	–	20	–			
PWM minimum pulse width high side	$T_{on_min_PWM}$	–	25	–			
PWM minimum off time	$T_{off_min_PWM}$	65	–	–			

¹ Maximum voltage range for tri-state

5 Theory of Operation

The TDA21220 incorporates a high performance gate driver, one high-side power MOSFET and one low-side power MOSFET in a single 40 lead QFN package. The advantages of this arrangement are found in the areas of increased performance, increased efficiency and lower overall package and layout inductance. This module is ideal for use in Synchronous Buck Regulators either as a stand-alone power stage that can deliver up to 50 A or with an interleaved approach for higher current loads.

The power MOSFETs are tailored for this device. The gate driver is a robust high-performance driver rated at the switching node for DC voltages ranging from -1 V to +25 V. The closely coupled driver and MOSFETs enable efficiency improvements that are hard to match using discrete components. The power density for transmitted power of this approach is approximately 40 W within a 36 mm² area.

5.1 Driver Characteristics

The gate driver of the TDA21220 has 2 voltage inputs, VCIN and VDRV. VCIN is the 5 V logic supply for the driver. VDRV is also 5 V and is used to drive the High and Low Side MOSFETs. Ceramic capacitors should be placed very close to these input voltage pins to decouple the sensitive control circuitry from a noisy environment.

The MOSFETs selected for this application are optimized for 5 V gate drive, thus giving the end user optimized high load as well as light load efficiency. The reference for the power circuitry including the driver output stage is PGND and the reference for the gate driver control circuit (VCIN) is CGND.

Referring to the Block Diagram page, VCIN is internally connected to the UVLO circuit and for VCIN voltages less than required for proper circuit operation will provide shut-down. VDRV supplies both, the floating high side drive and the low-side drive circuits. An active boot circuit for the high side gate drive is also included. A second UVLO circuitry, sensing the BOOT voltage level, is implemented to prevent false GH turn on during insufficient power supply level condition (BOOT Cap charging/discharging sequence). During undervoltage both GH and GL are driven low actively; further passive pull-down (500 kΩ) is placed across gate-source of both FETs.

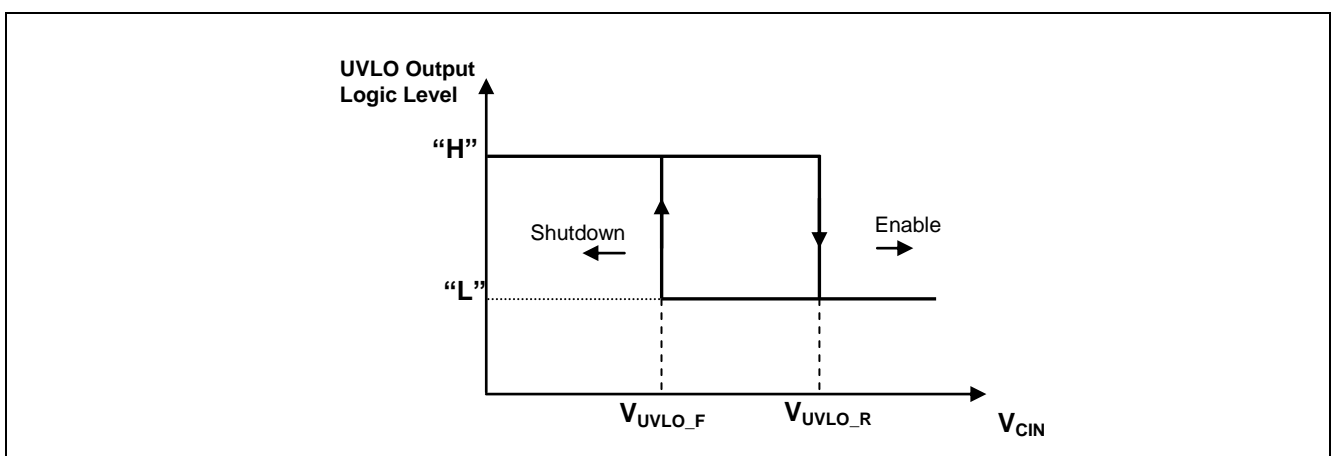

Figure 4 Internal Output Signal from UVLO Unit

5.2 Inputs to the Internal Control Circuits

The **PWM** is the control input to the IC from an external PWM controller and is compatible with 3.3 V.

The PWM input has three-state functionality. When the voltage remains in the specified PWM-shutdown-window for at least the PWM-shutdown-holdoff time T_{tsshd} , the operation will be suspended by keeping both MOSFET gate outputs low. Once left open, the pin is internally fixed to $V_{PWM_O} = 1.5$ V level.

Table 12 PWM Pin Functionality

PWM logic level	Driver output
Low	GL= High, GH = Low
High	GL = Low, GH = High
Open (left floating, or High impedance)	GL = Low, GH = Low

The possibility to use a wide range of VCIN power supply voltages (from 4.5 V to 5.5 V) implies a shifting in the threshold voltages for the following parameters: V_{PMW_O} , V_{PMW_H} , V_{PMW_L} . The typical behavior of these thresholds with the VCIN power supply is shown in the following graph:

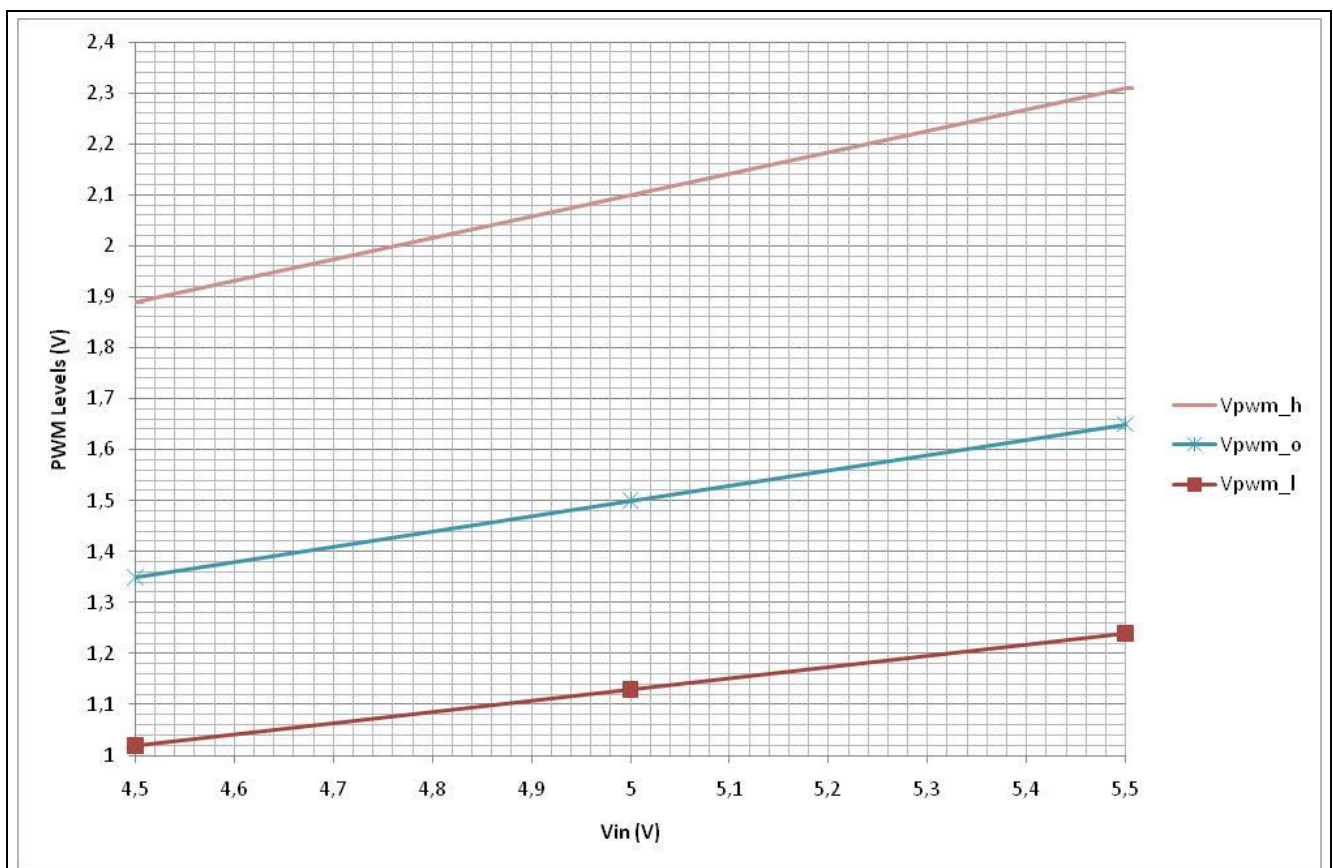

Figure 5 Variation of PWM Levels versus VCIN Logic Supply Voltage

Attention: The V_{PWM_S} also scales in the same way.

The **DISB#** is an active low signal. When DISB# is pulled low, the power stage is disabled. The disable pin is pulled down also during the thermal shut down condition.

Table 13 DISB# Pin Functionality

DISB# logic level	Driver output
Low	Shutdown : GL = GH = Low
High	Enable : GL = GH = Active
Open (left floating, or High impedance)	Shutdown : GL = GH = Low

The **SMOD#** feature is provided to disable the low sides MOSFET during active operation. When synchronized with the PWM signal, **SMOD#** intended to improve light load efficiency by saving the gate charge loss of the low-side MOSFET. Once left open, the pin is internally fixed to $V_{SMOD\#_O} = 3\text{ V}$ level.

Table 14 SMOD# Pin Functionality

SMOD# logic level	Driver output
Low	Shutdown : GL = Low GH = PWM
High	Enable : GL = GH = Active
Open (left floating, or High impedance)	Enable : GL = GH = Active

5.3 Shoot Through Protection

The TDA21220 driver includes gate drive functionality to protect against shoot through. In order to protect the power stage from overlap, both High Side and Low Side MOSFETs being on at the same time, the adaptive control circuitry monitors the voltage at the “VSWH” pin. When the PWM signal goes low, the High Side MOSFET will begin to turn off, after the propagation delay (T_{pdlu}). Once the “VSWH” pin falls below 1 V, the Low Side MOSFET is gated on after the predefined delay time, (T_{pdhl}). Additionally, the gate to source voltage of the High Side MOSFET is also monitored. When $V_{GS}(\text{High Side})$ is discharged below 1 V, a threshold known to turn High Side MOSFET off, a secondary delay is initiated, (T_{pdhl}), which results in Low Side being gated “ON” irregardless of the state of the “VSWH” pin. This way it will be ensured that the converter can sink current efficiently and the bootstrap capacitor will be refreshed appropriately during each switching cycle. See [Figure 9](#) for more detail.

GH and GL are monitoring pins to check the internal gate drive signals.

5.4 Safe Operating Area

The maximum load current versus the temperature of the PCB (below the device) is given below:

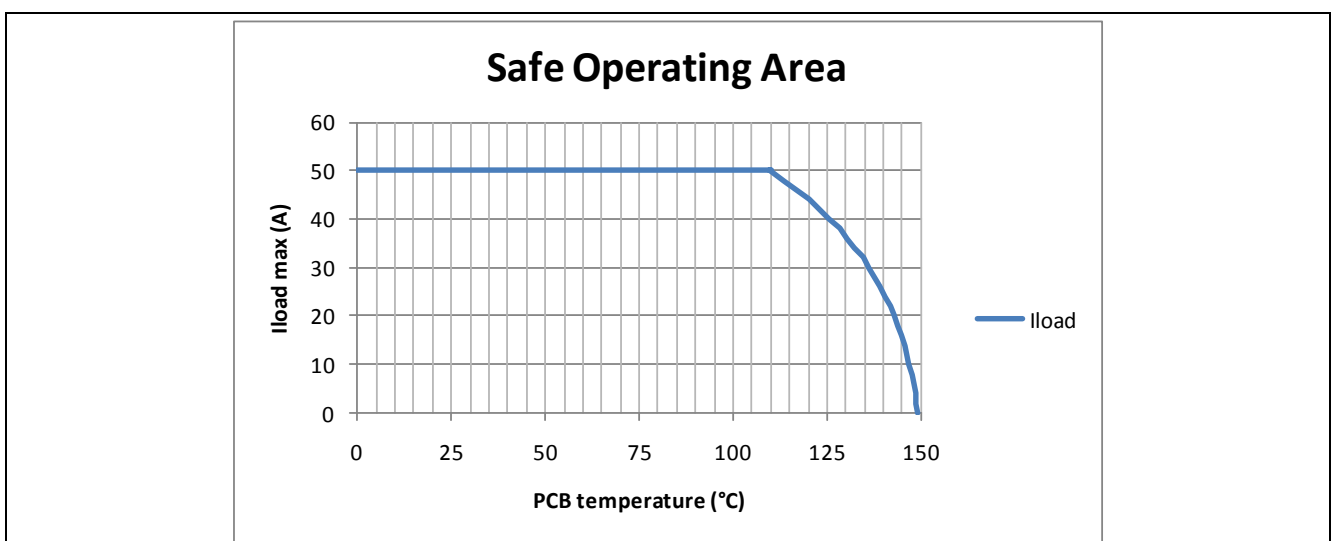

Figure 6 Safe Operating Area

6.2 Typical Application

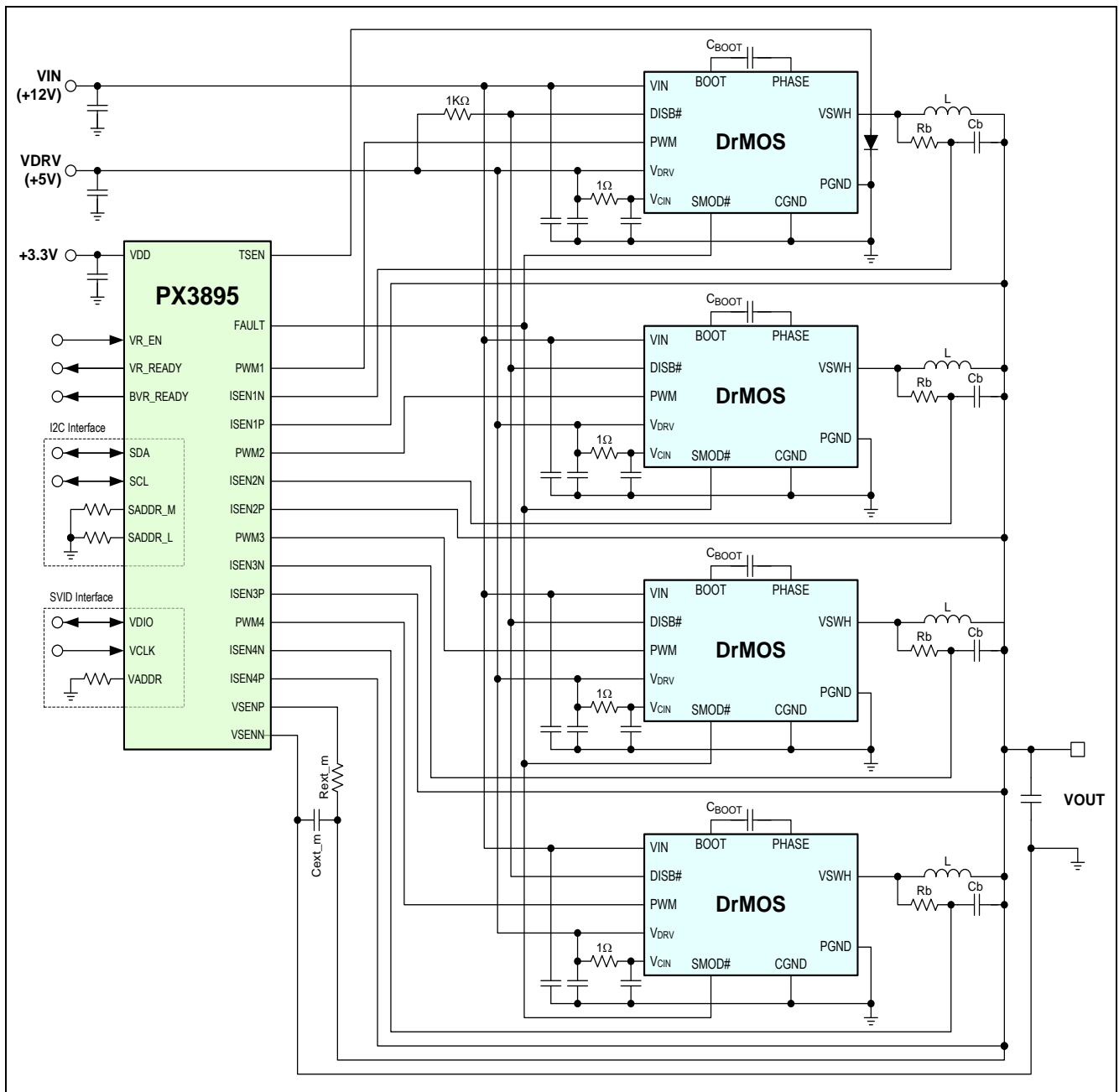

Figure 8 Four Phases Voltage Regulator Typical Application (Simplified Schematic)

7 Gate Driver Timing Diagram

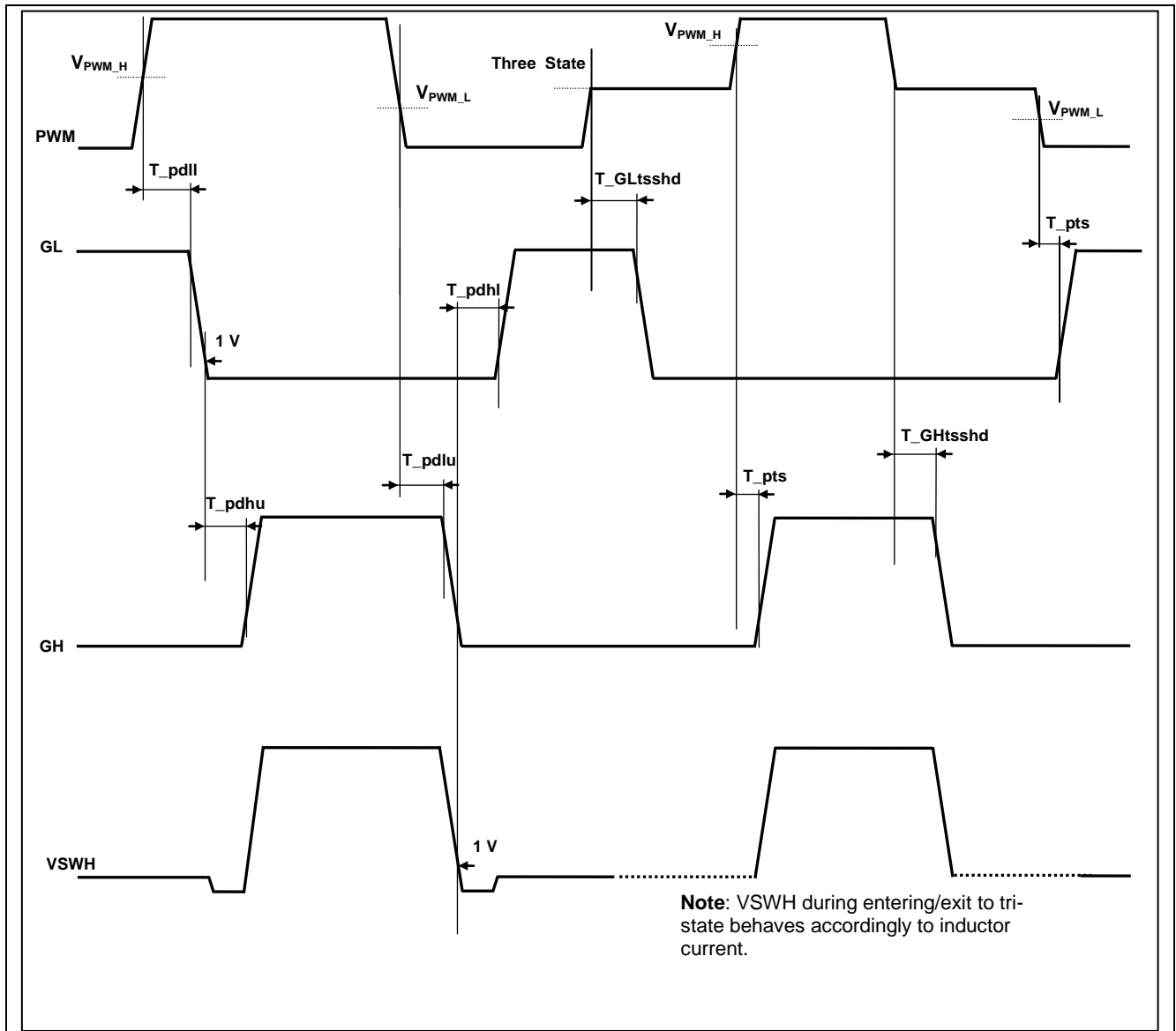

Figure 9 Adaptive Gate Driver Timing Diagram

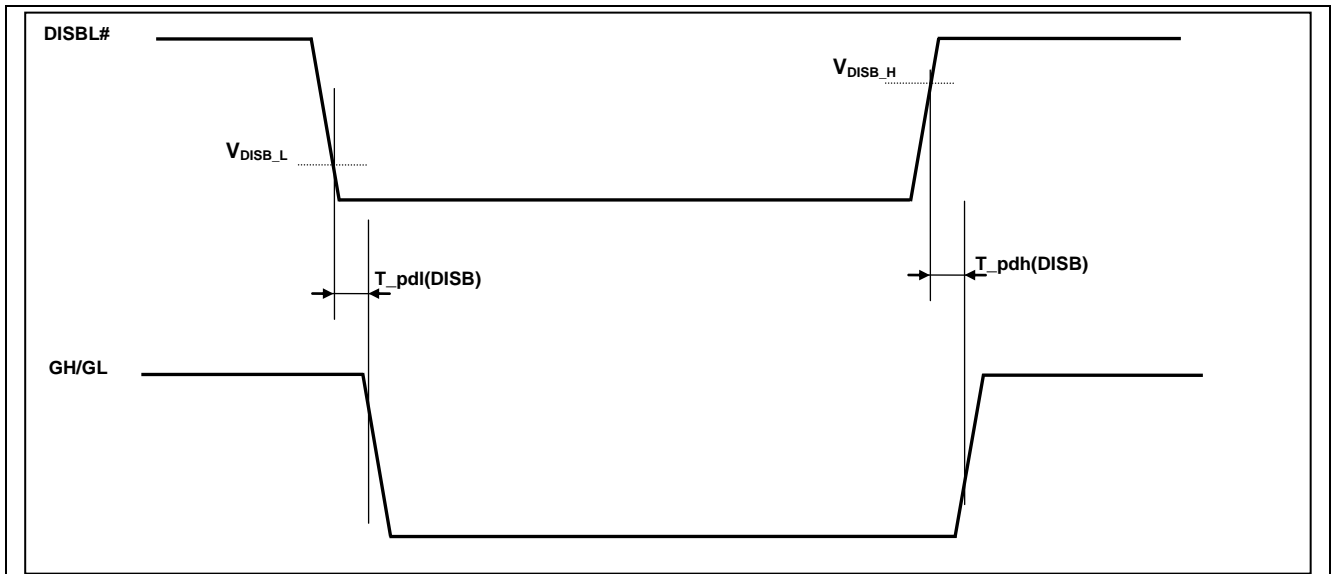

Figure 10 DISB# Timing Diagram

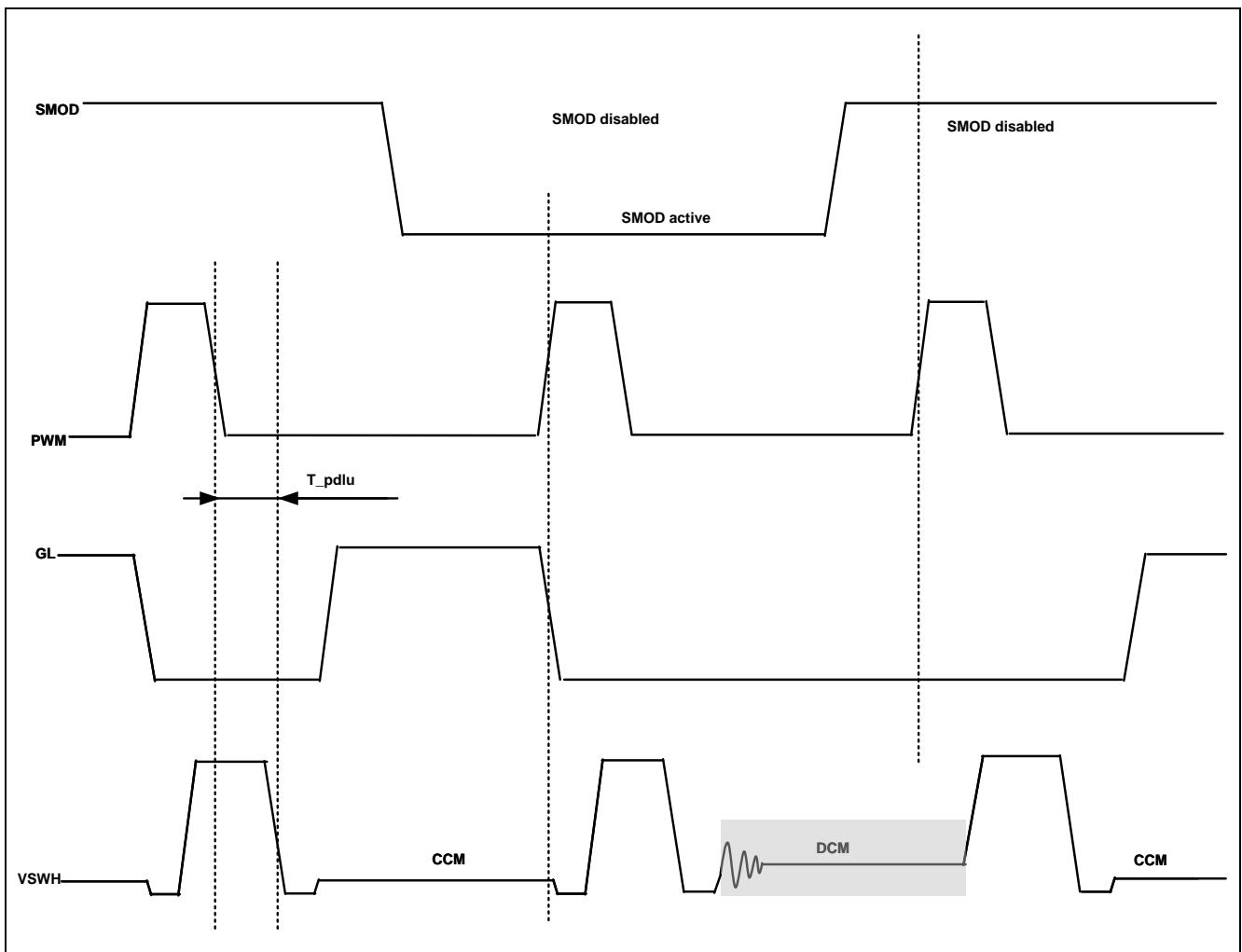

Figure 11 SMOD# Timing Diagram

8 Performance Curves – Typical Data

8.1 Efficiency and Power Loss versus Vout

Operating conditions (unless otherwise specified): $V_{IN} = +12\text{ V}$, $V_{CIN} = V_{DRV} = +5\text{ V}$, $V_{OUT} = 0.8\text{ V}$ to 1.6 V , $F_{SW} = 362\text{ kHz}$, 210 nH inductor (Cooper-FPI1108, $DCR(\text{typ}) = 0.29\text{ m}\Omega$) $T_A = 25^\circ\text{ C}$, load line = $0\text{ m}\Omega$, airflow = 100 LFM , no heatsink. Efficiency and Power Loss reported herein includes only TDA21220 losses. Data are taken after thermal equilibrium ($\sim 10\text{ min}$ for each current step) with unit in temperature chamber.

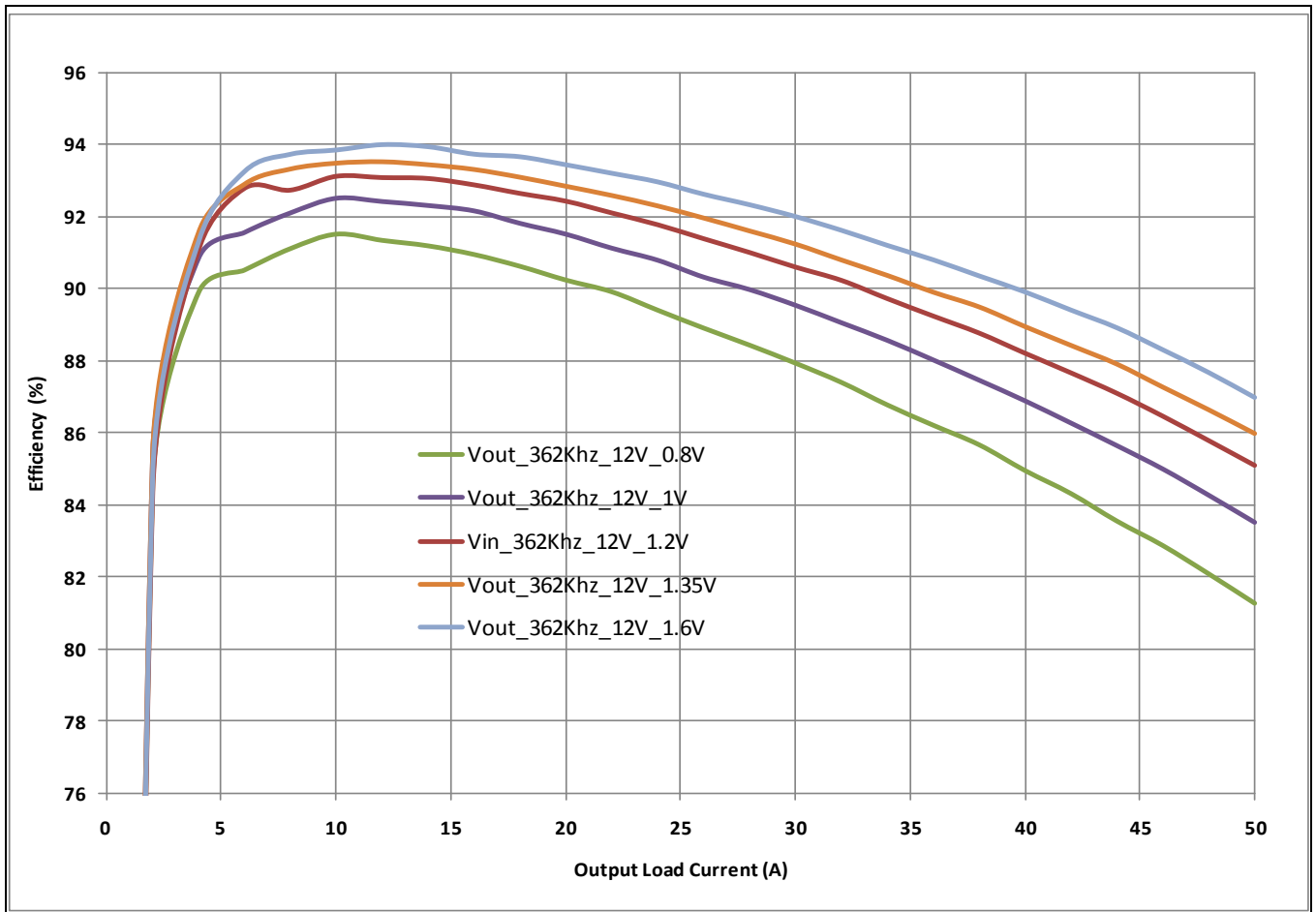

Figure 12 Efficiency vs. VOUT

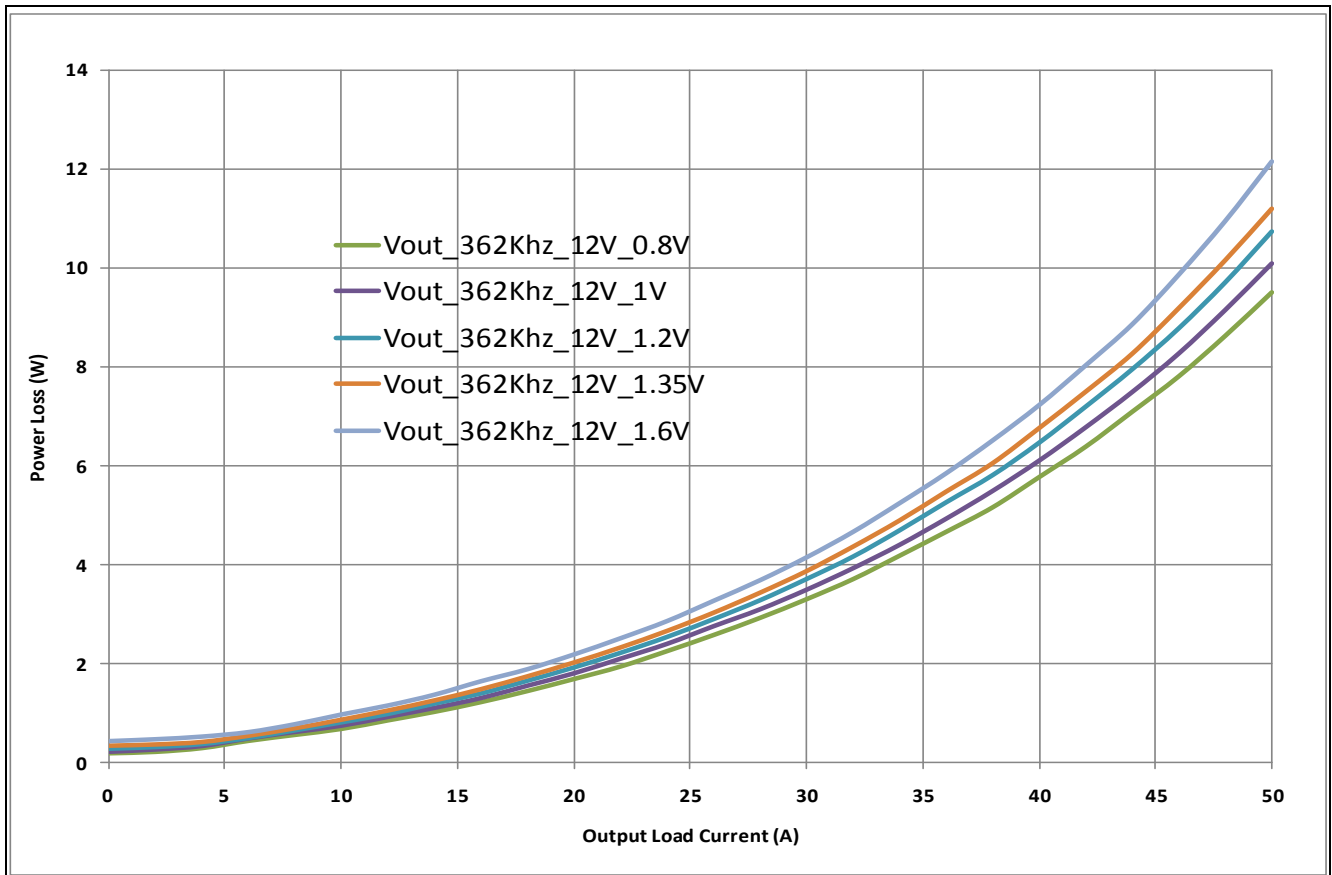

Figure 13 Power Loss vs. VOUT

8.2 Efficiency and Power Loss versus Vin

Operating conditions (unless otherwise specified): VIN = +10/12/14 V, VCIN = VDRV = +5 V, VOUT = 1.2 V, F_{SW} = 362 kHz, 210 nH inductor (Cooper-FPI1108, DCR (typ) = 0.29 mΩ) TA = 25° C, load line = 0 mΩ, airflow = 100LFM, no heatsink. Efficiency and Power Loss reported herein includes only TDA21220 losses. Data are taken after thermal equilibrium (~ 10 min for each current step) with unit in temperature chamber.

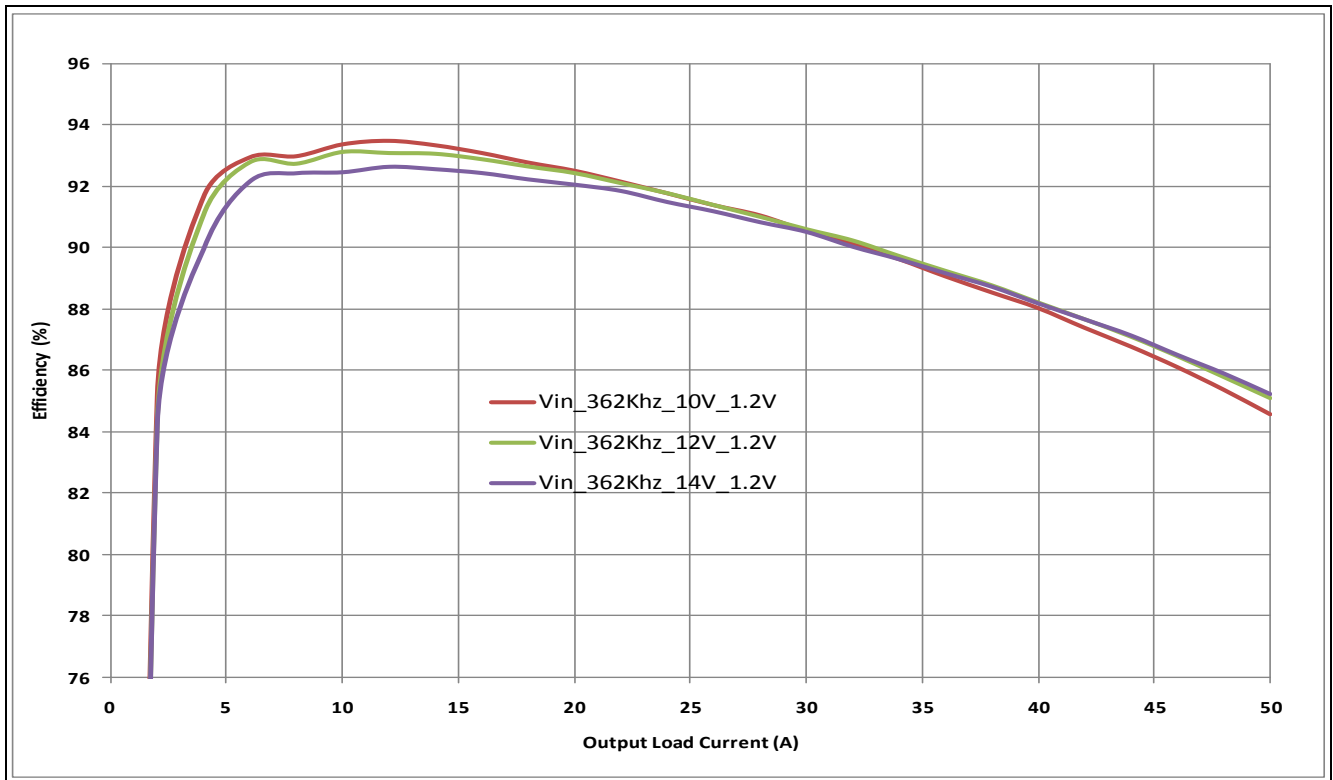

Figure 14 Efficiency vs. VIN

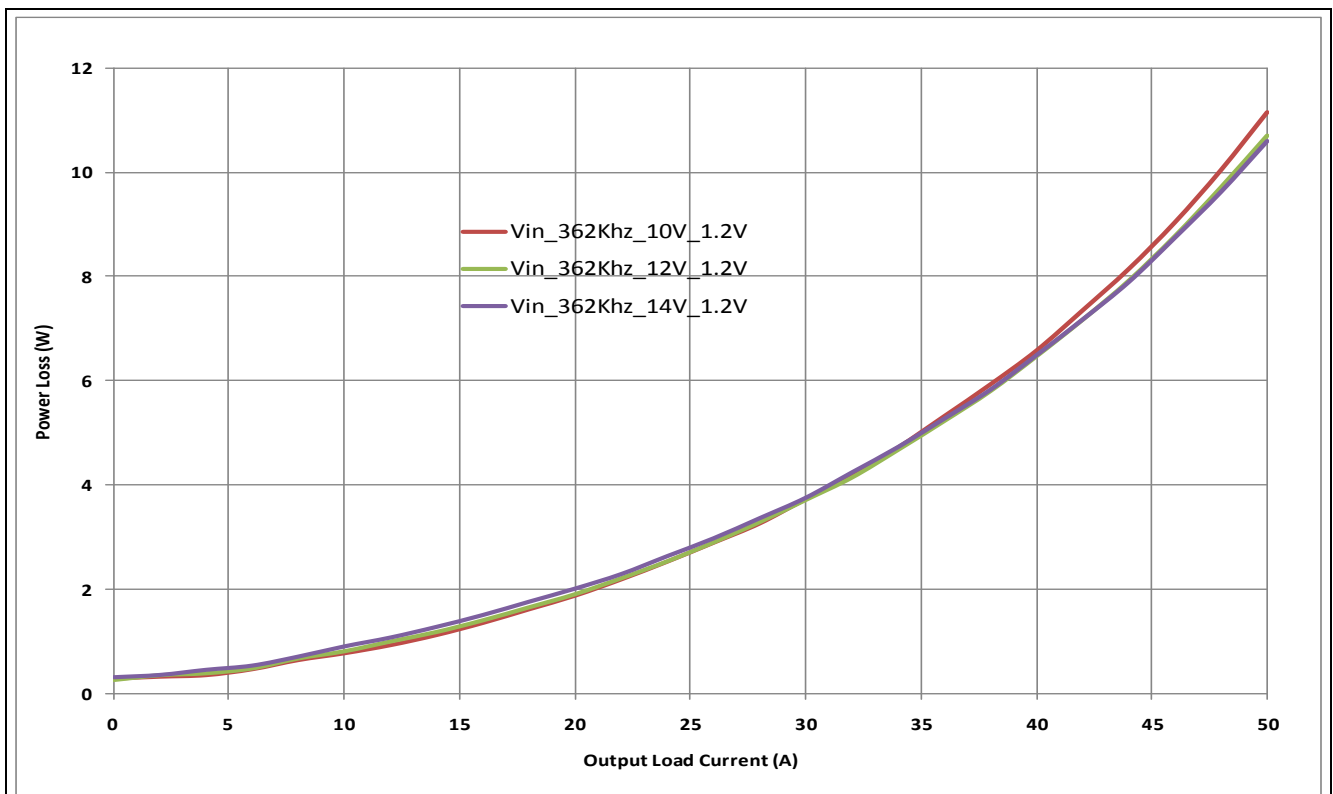

Figure 15 Power Loss vs. VIN

8.3 Efficiency and Power Loss versus Switching Frequency

Operating conditions (unless otherwise specified): VIN= +12 V, VCIN=VDRV= +5 V, VOUT=1.2 V, FSW = 296 kHz to F_{SW} = 592 kHz, 210 nH inductor (Cooper-FPI1108, DCR (typ) =0.29 mΩ) TA = 25° C, load line = 0 mΩ, airflow = 100LFM, no heatsink. Efficiency and Power Loss reported herein includes only TDA21220 losses. Data are taken after thermal equilibrium (~ 10 min for each current step) with unit in temperature chamber.

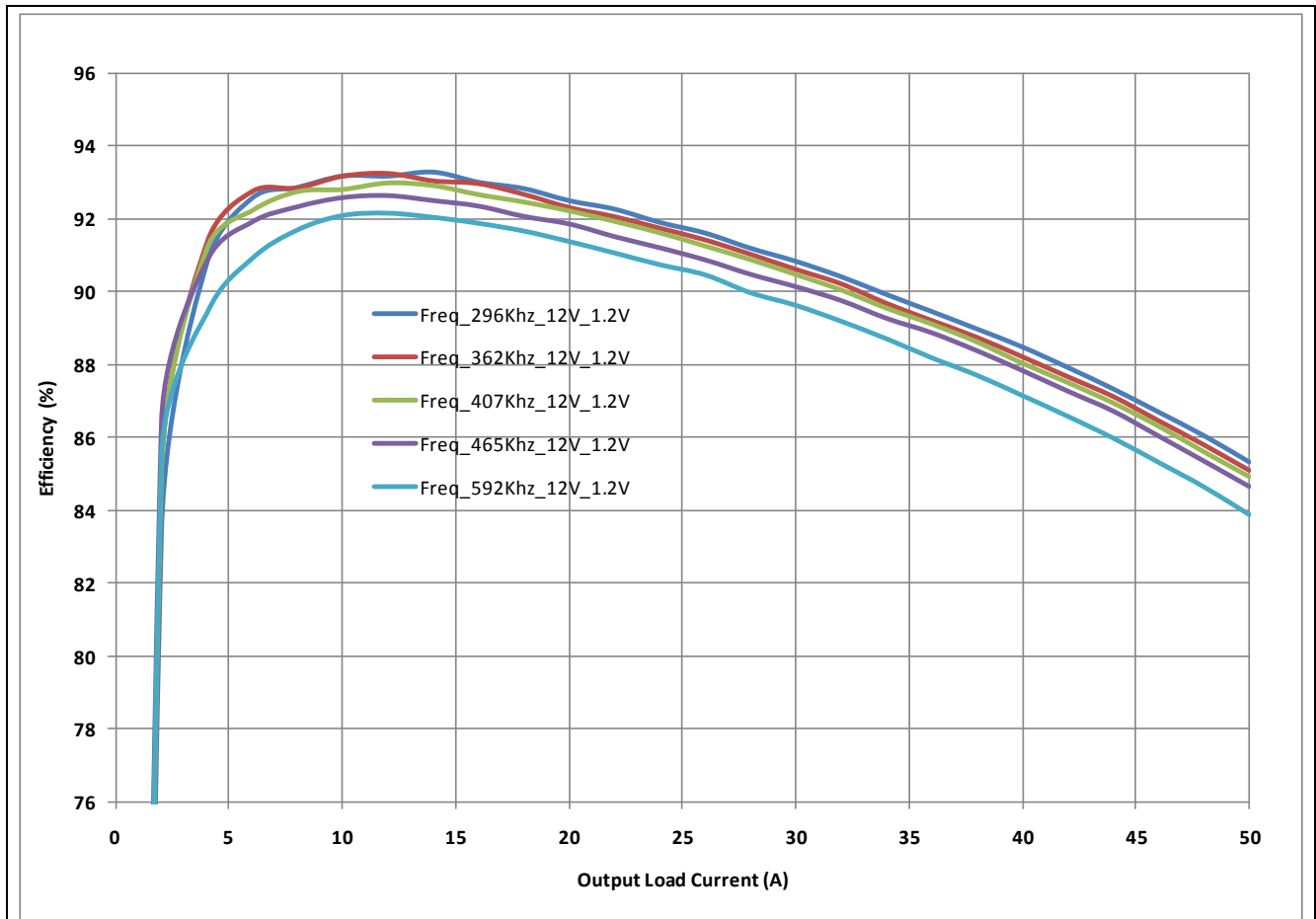

Figure 16 Efficiency vs. FSW

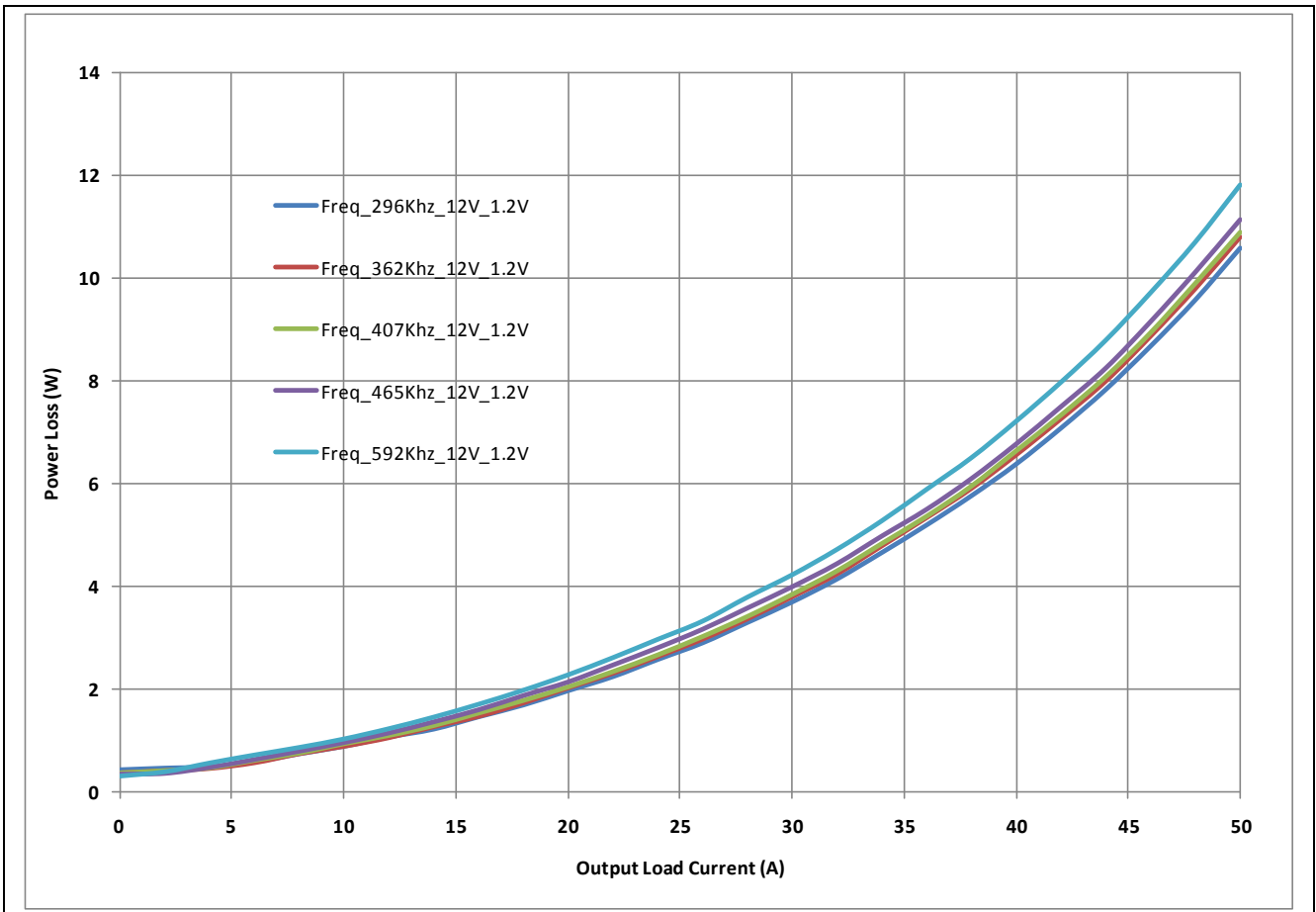

Figure 17 Power Loss vs. FSW

8.4 Driver Current versus Switching Frequency

Operating conditions (unless otherwise specified): VIN= +12 V, VCIN=VDRV= +5V, VOUT=1.2V, from $F_{SW} = 296 \text{ kHz}$ to $F_{SW} = 592 \text{ kHz}$, 210 nH inductor (Cooper-FPI1108, DCR (typ) = 0.29 mΩ) TA = 25° C, load line = 0 mΩ, airflow = 100 LFM, no heatsink. Efficiency and Power Loss reported herein includes only TDA21220 losses. Data are taken after thermal equilibrium (~ 10 min for each current step) with unit in temperature chamber.

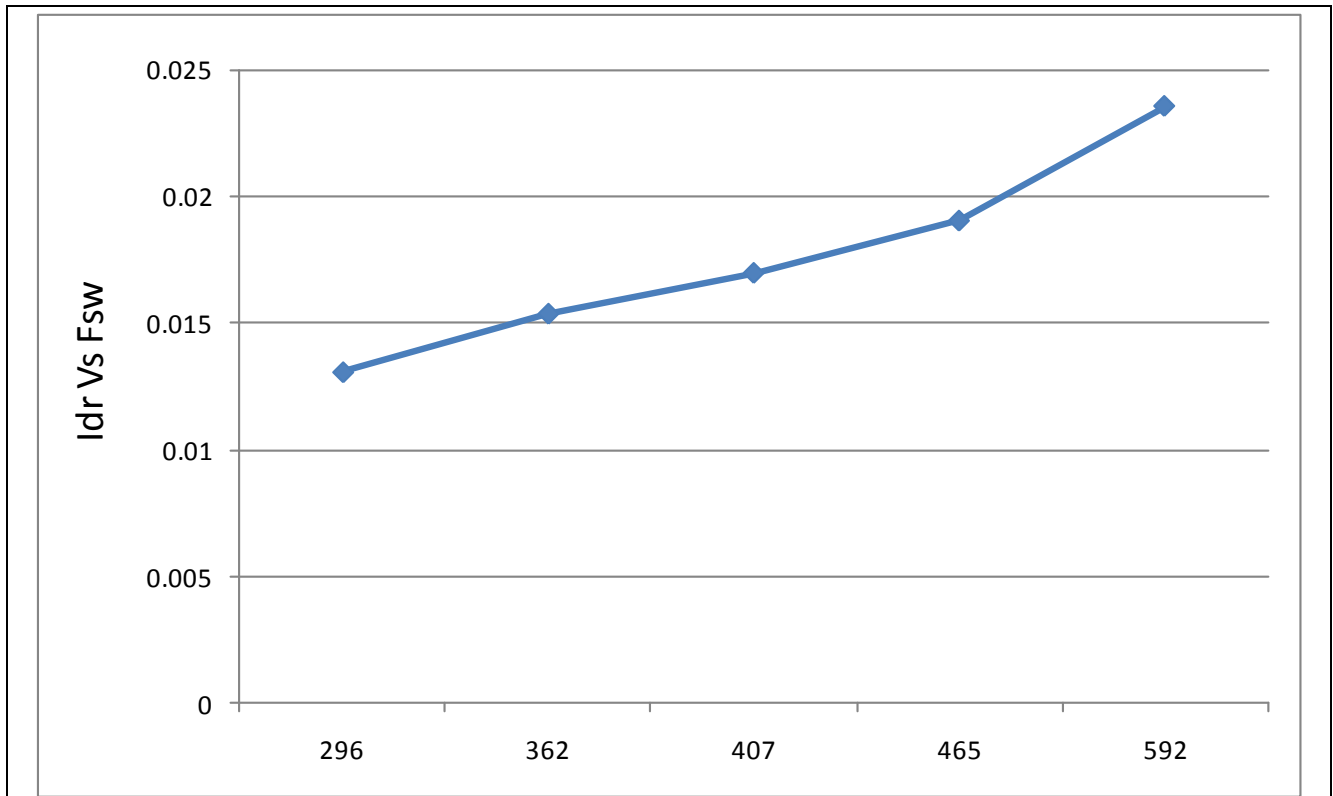

Figure 18 IDR Vs FSW

9 Mechanical Drawing

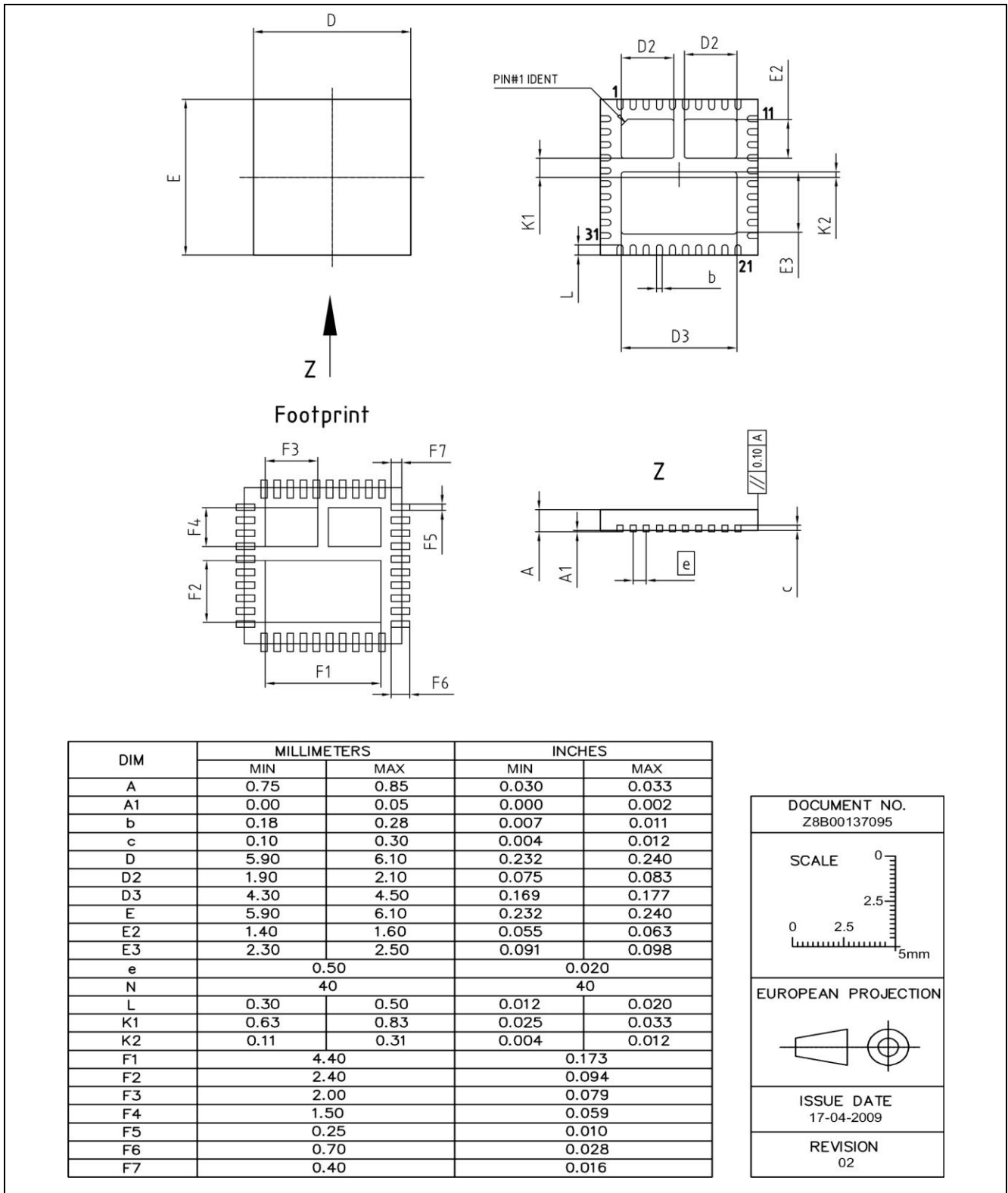

Figure 19 Mechanical Dimensions

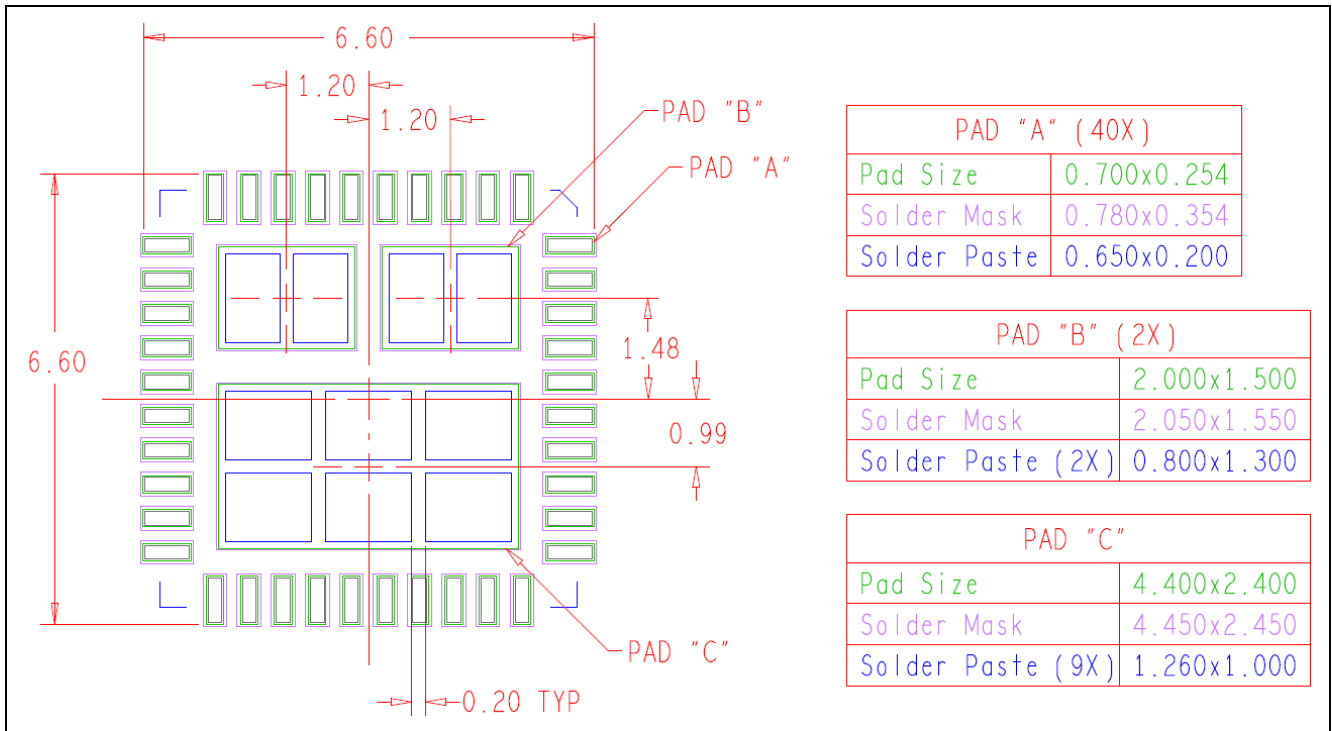

Figure 20 Footprint and Solder Stencil Recommendations

www.infineon.com

Published by Infineon Technologies AG